

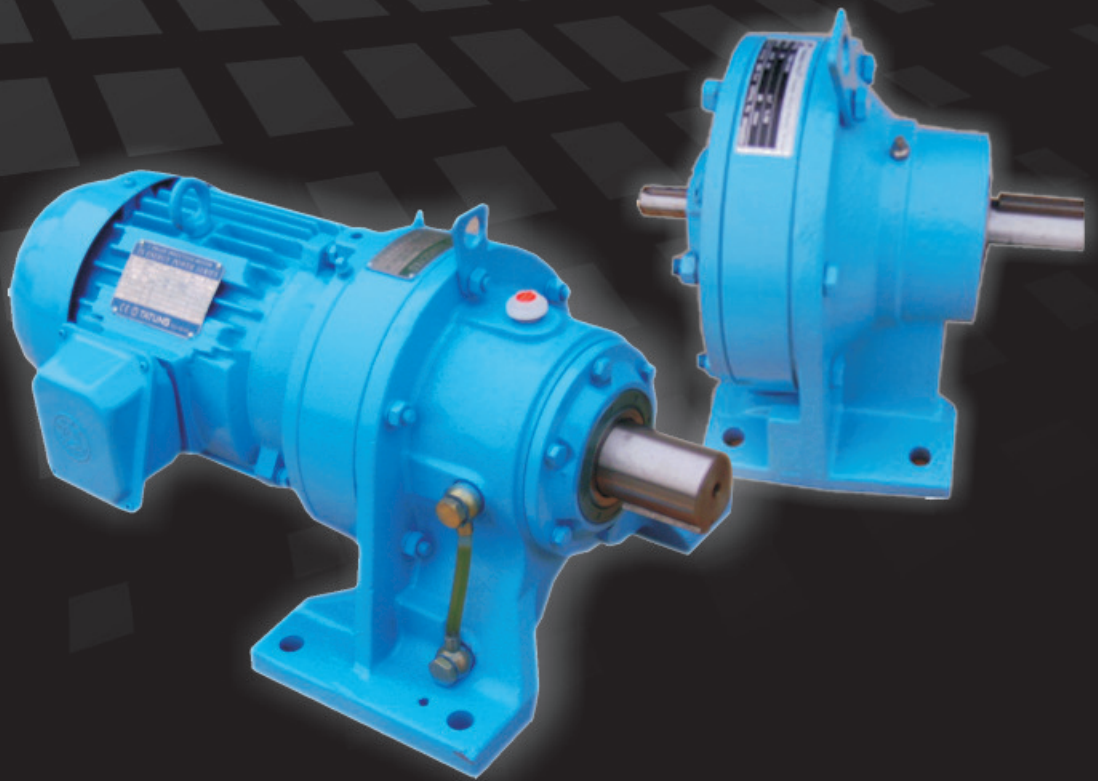

CYCLOIDAL SPEED REDUCERS

# 600 SERIES



ISO9001:2008RegisteredCompany

Transec Heavy Industry Co.,Ltd.  
Transmission Machinery Co.,Ltd.

**NO.TRANSCYKO-2017-06-CYCLO**

# TRANSCYKO PRODUCT LINE

1. CYCLOIDAL 600 SERIES



2. ROBOTIC TLB SERIES



3. PLANETARY TP SERIES



4. PLANETARY TP-C SERIES  
FOR CONCRETE MIXER



5. VARIABLE SPEED D SERIES



6. GEARBOX TSG TKED TCT  
TIN SERIES

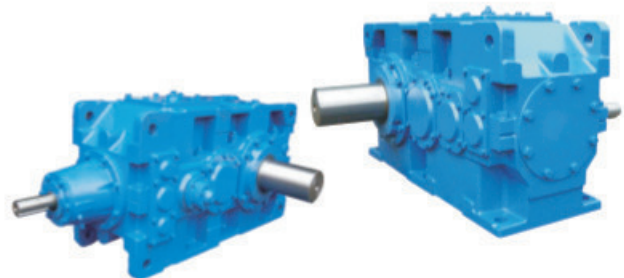

7. HELICAL/BEVEL TR TF TK TS SERIES



8. CYCLOIDAL DERIVATIVES  
TZS. TC SERIES





# TRANSCYKO CYCLOIDAL SPEED REDUCER PRODUCT SERIES

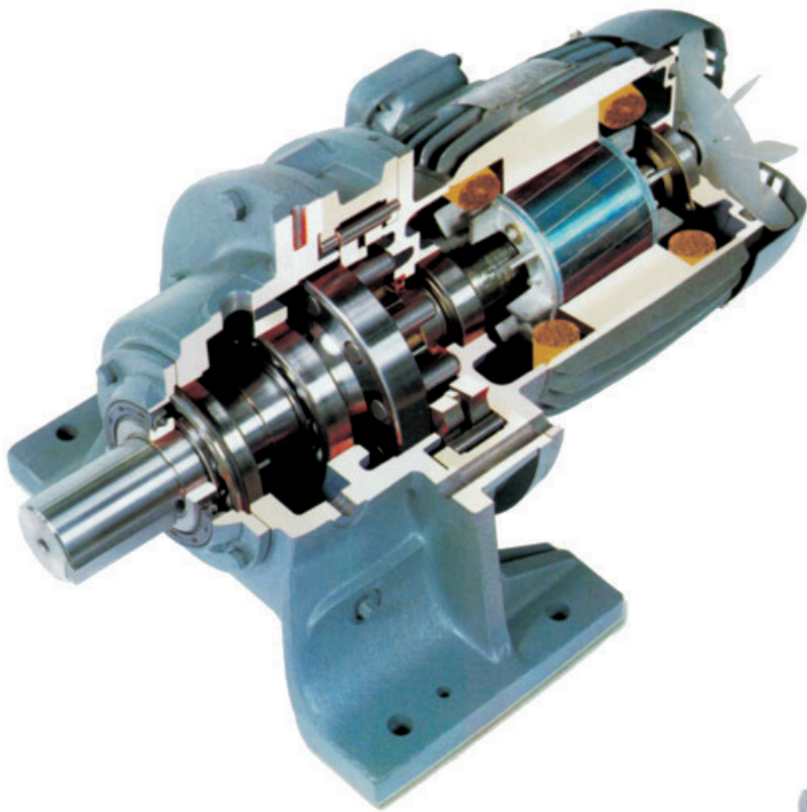

# TABLE OF CONTENTS

• Transcyko Product Line .....	1–2
• Advantages and Features .....	4–5
• General Information .....	6–7
• Design Criteria .....	8
• Lubrication and Maintenance .....	9–11
• Nomenclature–Model Designation .....	12
• Mounting Positions .....	13
• List of Standard Frame Sizes .....	14
• Combination of Ratios .....	15–16
• Torque Limiter Indication .....	17

## SELECTION AND DIMENSIONS OF TRANSCYKO GEARMOTORS

• How to select A suitable TRANSCYKO Gear Motors .....	18
• Selection Tables With 4 Pole Motor .....	19–44
• Selection Tables With 6 Pole Motor .....	45–47
• Dimension Drawings for Single Stage Reduction, Horizontal TRANSCYKO Gear Motors .....	48–67
• Dimension Drawings for Double Stage Reduction, Horizontal TRANSCYKO Gear Motors .....	68–103
• Dimension Drawings for Single Stage Reduction, Vertical TRANSCYKO Gear Motors .....	104–123
• Dimension Drawings for Double Stage Reduction, Vertical TRANSCYKO Gear Motors .....	124–159

## SELECTION AND DIMENSIONS OF TRANSCYKO SPEED REDUCERS

	160
• How to Select A Suitable TRANSCYKO Speed Reducer .....	161
• Selection Tables for Single Stage TRANSCYKO Speed Reducers .....	162–169
• Selection Tables for Double Stage TRANSCYKO Speed Reducers .....	170–179
• Dimension Drawing for Single Stage Reduction, Horizontal TRANSCYKO Speed Reducers .....	180–190
• Dimension Drawing for Double Stage Reduction, Horizontal TRANSCYKO Speed Reducers .....	191–208
• Dimension Drawing for Single Stage Reduction, Vertical TRANSCYKO Speed Reducers .....	209–219
• Dimension Drawing for F–TYPE Flange TRANSCYKO Speed Reducers .....	220–224
• Dimension Drawing for 608 TRANSCYKO Gear Motors .....	225
• Dimension Drawing for 608 TRANSCYKO Speed Reducers .....	226
• Selection Tables For 608 TRANSCYKO Gear Motors .....	226–229
• Selection Tables For 608 TRANSCYKO Speed Reducers .....	229
• Dimension Drawing for IEC Flange/NEME C–Face Adapters .....	230
• Dimension Drawing for IEC/NEME input Hollow Shaft Adapters .....	231
• Dimension Drawing for Top Mount Adapters .....	232
• Dimension Drawing for Shovel Base Speed Reducers .....	233

## REFERENCE DATA

• Allowable Overhung Load .....	234–235
• Related Formulas of Drive System .....	236
• Transcyko Global Success Stories .....	237–238



# ADVANTAGES AND FEATURES

TRANSCYKO 600 Series Speed Reducers are industry proven and highly efficient compared to conventional helical gear and spur gear units. Due to their compact size relative to their high ratios, TRANSCYKO Cycloidal Speed Reducers can be utilized in a wide variety of industrial applications.

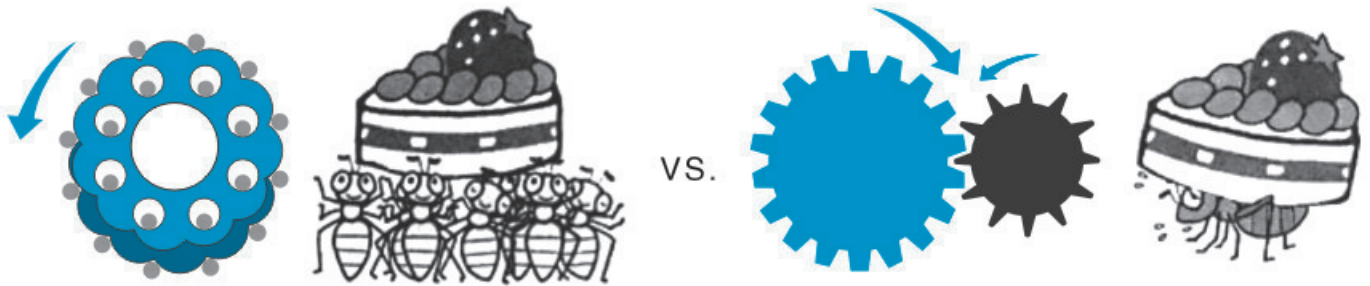

## ADVANTAGES

### HIGH EFFICIENCY

Cycloidal toothed gears transmit torque by discs that circle around the outside and inside of each other. With this type of engagement, it eliminates sliding friction and vibrations which are typically found in the conventional toothed gear designs.

TRANSCYKO 600 Series Speed reducers are highly efficient, more than 96% in single stage reduction and more than 92 % in double stage reduction.

Annotation: one stage reduction ratio within 87 and double stage reduction ratio within 7569.

### OVERLOAD PROTECTION

TRANSCYKO's cycloidal tooth design is capable of reaching up to 67% tooth contact. The load sharing capacity provides an overload protection of 500%.

### ONE YEAR WARRANTY

TRANSCYKO Cycloidal Speed Reducers are proven to be reliable and durable under proper selection and maintenance. We provide 1 year warranty on all cycloidal speed reducer products under normal operation.



## **FEATURES**

### **A CUSTOMIZED MODEL FOR EVERY NEED**

TRANSCYKO can manufacturer a wide variety of speed reducers in different sizes, ratios, input horsepower (hp), mountings and configurations.

Reduction ratio ranges from 6:1 to 119:1 in single stage; up to 7569:1 in double stage and almost 1,000,000:1 in triple stage. Input horsepower ranges from 1/16 hp to over 200 hp. Output torque ratings of up to 6000 kg m (500,000 lb-in). We offer horizontal and vertical mounts with various IEC/NEMA input adaptors to ease installation.

TRANSCYKO housings are made from ductile iron for durability. We use 52100 bearing steel to manufacture the internal components which are also hardened and tempered (Rockwell Rc. 59-62). All of these elements allow TRANSCYKO to build highly efficient cycloidal speed reducers, but without the output torque loss like with conventional helical reducers.

### **TRANSCYKO featured:**

#### **QUIET AND SMOOTH RUNNING**

TRANSCYKO's cycloidal design differs from conventional gear tooth design by utilizing hardened and polished surfaces which allow for a quiet and smooth running reducer with minimized vibration levels.

#### **IDEAL FOR STOP/START AND REVERSING OPERATION**

TRANSCYKO's cycloidal design allows for a relatively low rotational inertia which is ideal for applications that call for stop/start and reversing operation.

#### **ECONOMICAL**

TRANSCYKO can reduce out of pocket costs significantly by offering higher durability and reliability with low maintenance, unlike our competitors.

#### **QUALITY**

TRANSCYKO is committed to produce high quality cycloidal speed reducers. We have extensive production machinery, highly experienced engineers and conform to ISO certification to help ensure on-time delivery.

**Annotation: Frames 607-619 are cast iron, however, ductile iron is available upon request.  
Frames 620-627 are ductile iron.**

# GENERAL INFORMATION

The cycloidal design basically has three major components.

- (1) Input shaft assembly (high speed) with eccentric cam, roller bearing and seals.
- (2) Cycloid discs.
- (3) Output shaft assembly (slow speed) with support bearings and seals.

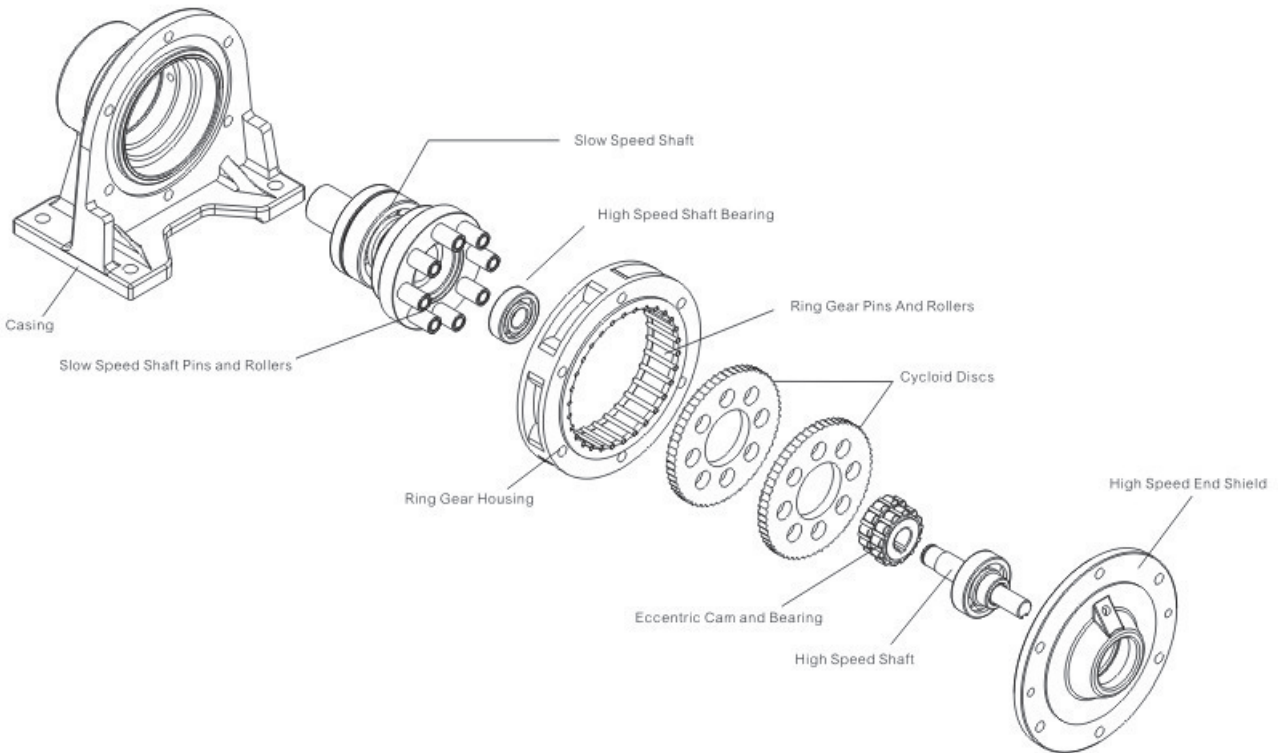

Torque transmitted to the high speed shaft rotates the eccentric cam and roller bearing assembly, and rolls the cycloid discs around the internal circumference of the stationary ring gear housing.

The teeth of the cycloid discs contact the pins of the stationary ring gear, producing a reverse rotation at a reduced speed. Each rotation of the high speed shaft advances the cycloid discs a distance of one tooth pitch in the opposite direction.

The reduced rotation of the cycloid discs is transmitted to the output shaft assembly by means of drive pins and rollers, that are projected through holes located around the bore of the cycloid discs.

# GENERAL INFORMATION

## Shaft Rotation

For single and triple reduction units, the low speed shaft turns in the opposite direction to the high speed shaft. For double reduction drives, the low speed and high speed shafts turn in the same direction.

Note : On all TRANSCYKO Speed Reducers, the high speed and low speed shafts have the same common axis.

## Motor Input Speed (nominal)

1800 R.P.M., 1500 R.P.M., 1200 R.P.M., 1000 R.P.M., 900 R.P.M., 750R.P.M., 600 R.P.M.

Note: For non-standard input speed, please contact your factory representative to confirm torque ratings.

## Shaft Connections

Proper mounting of sheaves, gears, pulleys, chain sprockets, belt and couplings are required to ensure trouble-free operation.

All shaft connections must be mounted as close as possible but never touching the cycloidal housing. Apply overhung loads as close to the bearings as possible to prevent excessive loading on the bearings and possible shaft deflection. It is also strongly suggested that radial loads are applied at the midpoint of the slow speed shaft. These alignment procedures lead to successful function and efficient performance. Contact your factory representative to confirm proper selection as needed.

Annotation:

Permissible torsional forces such as thrust and radial loads applied to the low speed shafts must be calculated to determine allowable limits for each selection.



# DESIGN CRITERIA

TRANSCYKO Cycloidal Speed Reducers are designed and manufactured to be utilized under uniform loading for ten (10) consecutive hours daily, which is equivalent to AGMA service factor of 1.0. Proper drive selection is required depending on hours of daily operation and loading conditions which are determined by Service Factor (S.F.)

## Recommended TRANSCYKO Load Factors

Hours of daily operation \ Load conditions	U Uniform Loading		M Moderate Shock Loading		H Heavy Shock Loading	
	TRANSCYKO	AGMA 1	TRANSCYKO	AGMA 2	TRANSCYKO	AGMA 3
Continuous Running ~3 hours	0.80	0.80	1.00	1.00	1.35	1.50
Continuous Running ~10 hours	1.00	1.00	1.20	1.25	1.50	1.75
Continuous Running ~24 hours	1.20	1.25	1.35	1.50	1.60	2.00

## Machine Load Classifications:

### Agitators

- U Pure liquid
- M Liquids+solids
- M Variable-viscosity liquids

### Brewing&distilling equip.

- U Capping machine
- U Can machine
- M Weighing machine
- M Pulling machine
- U Cooker

### Pottery machines

- M Mixer
- H Brick press
- M Grinding machine

### Conveyors(average)

- U Segmented
- M Accumulator. type
- U Bell
- U Bucket
- U \*Oven-type
- U Screw-type

### Conveyors(heavy duty)

- M Segmented
- M Belt
- M Suspension bucket
- M Screw-type
- M Hopper-type
- H \*Reciprocating
- H Rocker-type

### Winches

- M Suspension. bucket
- M Horizontal
- M Vertical
- H Main hoist(heavy duty)
- M Main hoist(heavy duty)

### Crushers

- H Diamond
- H Stone
- M Raw sugar

### Dredges

- M Cable drum
- M Conveyor
- H Cutting head
- H Mold-board drive
- M Winch
- M Pump
- M \*Stacker
- H Seine drive

### Elevator

- U Suspension hopper(avg.10ad)
- M Suspension hopper(heavy duty)
- M Suspension hopper(continuous)
- U Escalator
- M Cargo
- M Utility

### Feed supply systems

- M Segmented belts
- U \*Round segment types
- H \*Reciprocating
- M Screw-type

### Food processing

- M Raw sugar&turnip cutters
- U \*Ovens
- M Meat slicers
- M Noodle mixer

### Axies

- M Drive train
- U Lightly loaded
- U Other axes

### Timber equipment

- H \*Reservoir pumps
- H Chain&\*drogue saws
- H Chain transmission
- H Brake drum
- H Gear boxes
- H Segmented conveyors
- U Sawdust conveyor(belt)
- M Sawdust conveyor(chain)
- M \*Sorting conveyor
- M Utility conveyor

### Sheet metal equipment

- M Forming rolls
- H Punch press(drive gear)
- H Flat planer
- H Drill
- M Other main drives
- U Auxiliary drives

### Machine shop equipment

- M \*Table feeds
- H Shapers
- Non-reversible conveyors
- M \*Collective drives
- H Individual drives
- H Screw machines

### Solid-material mixers

- M Cement drums
- M Dryers,coolers
- M \*Kilns
- M Gravel
- M \*Barrel packers
- H \*Pellet-abrasion machines

### Liquid mixers

- M Concrete(continuous duty)
- M Concrete(\*intermittent)
- U Fixed viscosity
- M Variable viscosity

### Petroleum equipment

- M Stack coolers
- Well-head pumps
- M \*Pressurized lubricant drives
- M \*Reversing kiln

### Sugar Industry

- H Mills
- M Crushers
- M Cane Knives

### Rubber processing equip

- M Rubber strainer
- M Roll
- M \*Thin plate
- M Mixer

### Paper-making equipment

- M Agitator
- M \*paper-maker
- M De-barker
- M Beater
- M Impact-type beater
- U Bleacher
- M Pressurized strainer
- H Large strainer
- U Conveyor
- M Dryer
- M \*Felt extender
- H \*Felt press
- M Finishing press

### Textile(fiber)equipment

- M Carding machine
- M Strainer
- M Dryer
- M Dyer
- M Washing machine
- M Spinning machine
- M \*Lapping machine

### Water treatment equip.

- U Sludge recovery machine
- M Sludge compactor
- M Low&high speed mixers
- U Chemical-supply devices

### Steel Industry

- H FORMING machine
- C Reversing pinch. dryer & scrubber roll
- M Slitters
- M Draw bench carriage & main drive
- C Reversing table conveyor
- M Group drive of non-reversing table conveyor
- H Individual drive of non-reversing table conveyor
- M Wire winding, wire drawing & flattening machines

**C-Contact us**

**\*-Refer to factory**

# LUBRICATION AND MAINTENANCE

## Mounting

Horizontal and vertical oil lubricated drives should be mounted on a level or plumb to ensure proper lubrication. Select the proper grease and oil lubrication system according to the size and ratio of TRANSCYKO Cycloidal Speed Reducer. Please refer to the tables shown below.

## Standard Lubrication Type

### Horizontal

#### a) Standard Single Reduction

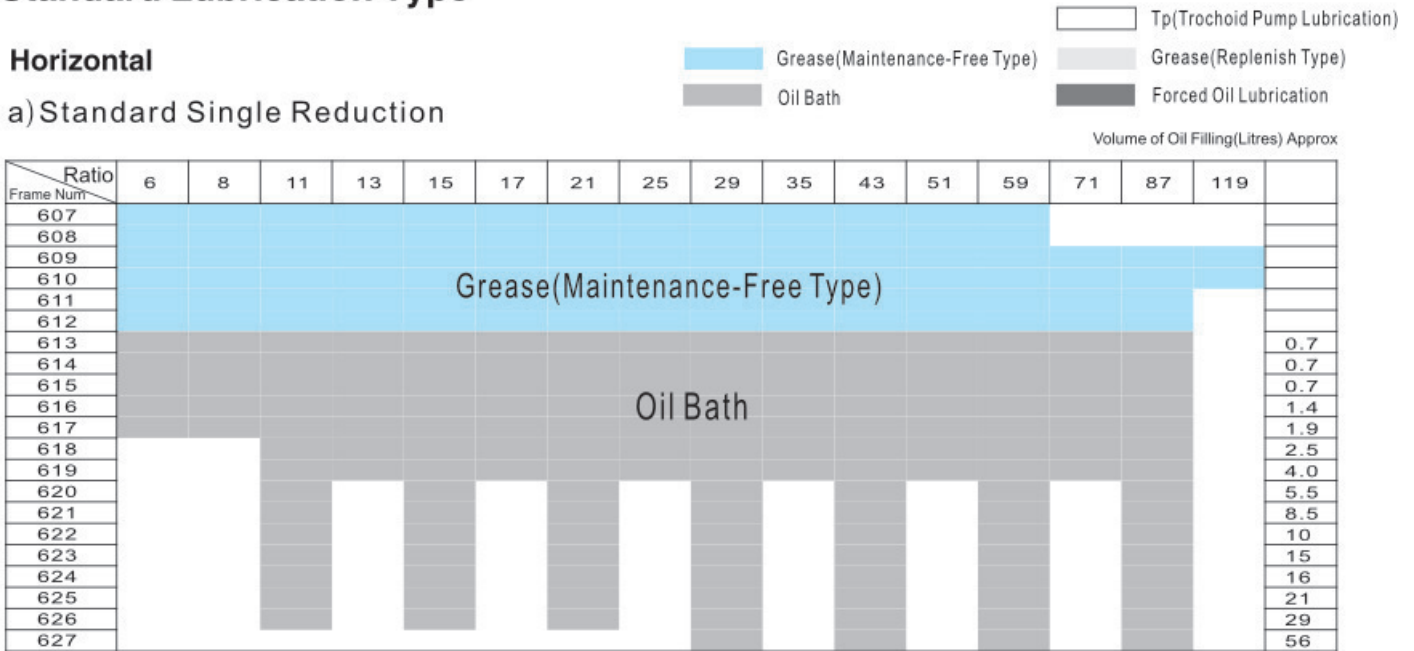

#### b) Standard Double Reduction

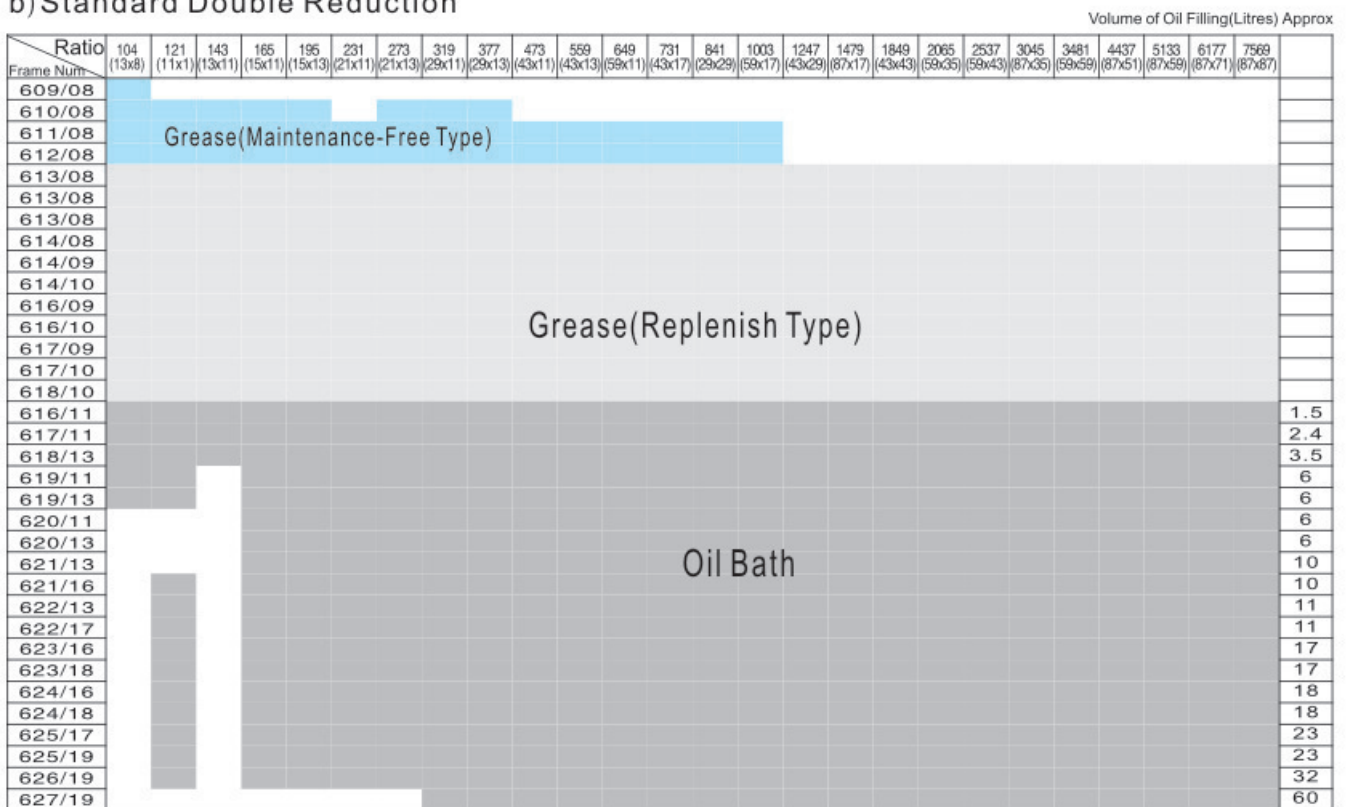

## Vertical

### a) Standard Single Reduction

Volume of Oil Filling(Litres) Approx

Ratio	6	8	11	13	15	17	21	25	29	35	43	51	59	71	87	119	
Frame Num																	
607																	
608																	
609																	
610																	
611																	
612																	
613																	1.1
614																	1.1
615																	1.1
616																	1
617																	1.9
618																	2
619																	2.7
620																	5.7
621																	7.5
622																	10
623																	12
624																	15
625																	42
626																	51
627										TP		TP		TP		TP	( 60 )

### b) Standard Double Reduction

Volume of Oil Filling(Litres) Approx

Ratio	104	121	143	165	195	231	273	319	377	473	569	649	731	841	1003	1247	1479	1849	2065	2537	3045	3481	4437	5133	6177	7569		
Frame Num																												
609/08																												
610/08																												
611/08																												
611/09																												
613/08																												
613/09																												
613/10																												
614/08																												
614/09																												
614/10																												
616/09																												
616/10																												
617/09																												
617/10																												
618/10																												
616/11																												1
617/11																												1.9
618/13																												2
619/11																												2.7
619/13																												2.7
620/11																												11
620/13																												11
621/13																												14
621/16																												14
622/13																												18
622/17																												18
623/16																												23
623/18																												23
624/16																												29
624/18																												29
625/19																												42
626/19																												54
627/19																												( 60 )

TP:Use pump lubrication for output shaft Down but not out put shaft Up.

## Grease Lubricated Speed Reducers

Grease Lubricated Speed Reducers are factory sealed and ready for operation. Maintenance-free Grease lubricated Speed Reducers are designed to utilize designated long-life grease for worry-free operation. TRANSCYKO suggests replacement of grease lubrication every 4-5 years or every 20,000 hours of operation whichever comes first.

Please replenish or replace grease lubrication for all other maintenance-free types according to the service manual.



## Recommended Grease Lubricants for TRANSCYKO Speed Reducers

Ambient Temperature °C(F)	Maintenance-Free Grease	Replenish Grease	Electric Motor
-15~50 (5~122)	Shell Alvania Grease RA or equivalent	Shell Alvania Grease No.2, Cosmo Grease Dynamax SH No.2 or equivalent	Shell Alvania Grease No.2 or equivalent

## Oil Lubricated Speed Reducers

Oil Lubricated Speed Reducers are factory sealed and pre-lubricated with oil. Please confirm oil level which should be located in between the red lines of oil gauge before operation. Mild EP oil is recommended to lubricate TRANSCYKO Speed Reducers.

## Recommended Oil Brand and Specifications(or equivalent)

Ambient Temperature °C ( F )	Shell Oil	Mobil Oil	BP Oil	Esso Oil	Gulf Oil	Caltex Oil	SAE Grade	AGMA Grade
-15~5 ( 5~41 )	Omala Oil 86	Mobilgear 626 (ISO VG 68)	Energol GR-xp 46 GR-xp 68	Spartan EP 68	EP Lubricant HD 68	Meropa 68	80W	2EP
0~35 ( 32~95 )	Omala Oil 100,150	Mobilgear 627 629 (ISO VG 100-150)	Energol GR-xp 100 GR-xp 150	Spartan EP 100 EP 150	EP Lubricant HD 100 HD 150	Meropa 100,150	80W 90	3EP 4EP
30~50 ( 86~122 )	Omala Oil 220,320, 460	Mobilgear 630 632,633,634 (ISO VG 200-460)	Energol GR-xp 220 GR-xp 320 GR-xp 460	Spartan EP 220 EP 320 EP 460	EP Lubricant HD 220 HD 320 HD 460	Meropa 220, 320 460	90 140	5EP 7EP

\*use lower viscosity oil for winter or relatively low ambient temperature.

There are two types of Forced - Oil Lubrication for vertical units:

- 1.Plunger Pump Lubrication(P) is driven by a cam fitted on the slow speed shaft automatically.
- 2.Trochoid Pump Lubrication(TP):The Oil circulation is conducted by an independent operation of pump and motor.This table shows the application of Trochoid Pump Lubrication.

TRANSCYKO Speed Reducers		Trochoid Pump	
Frame Size		Pump Type	Pump Motor
Single Stage	627	TOP-216HA	0.75kw(1HP),4p
Double Stage	627/19	TOP-204HA	0.4kw(1/2HP),4p

## Oil Change Interval

Under all circumstances, each TRANSCYKO unit requires a first oil change post 500 hours of initial operation as a break-in period. Subsequent oil change interval will be based on operation conditions.

Every 6 months	less than 10 hours / day operation
every 2500 hours	10~24 hours / day operation
every 1~3 months	heavy operation condition such as high ambient temperature & high humidifies.

For specific details of lubrication and maintenance,please refer to the Operating and Maintenance Manual.

# TRANSCYKO SPEED REDUCER MODEL DESIGNATION NO:600 SERIES

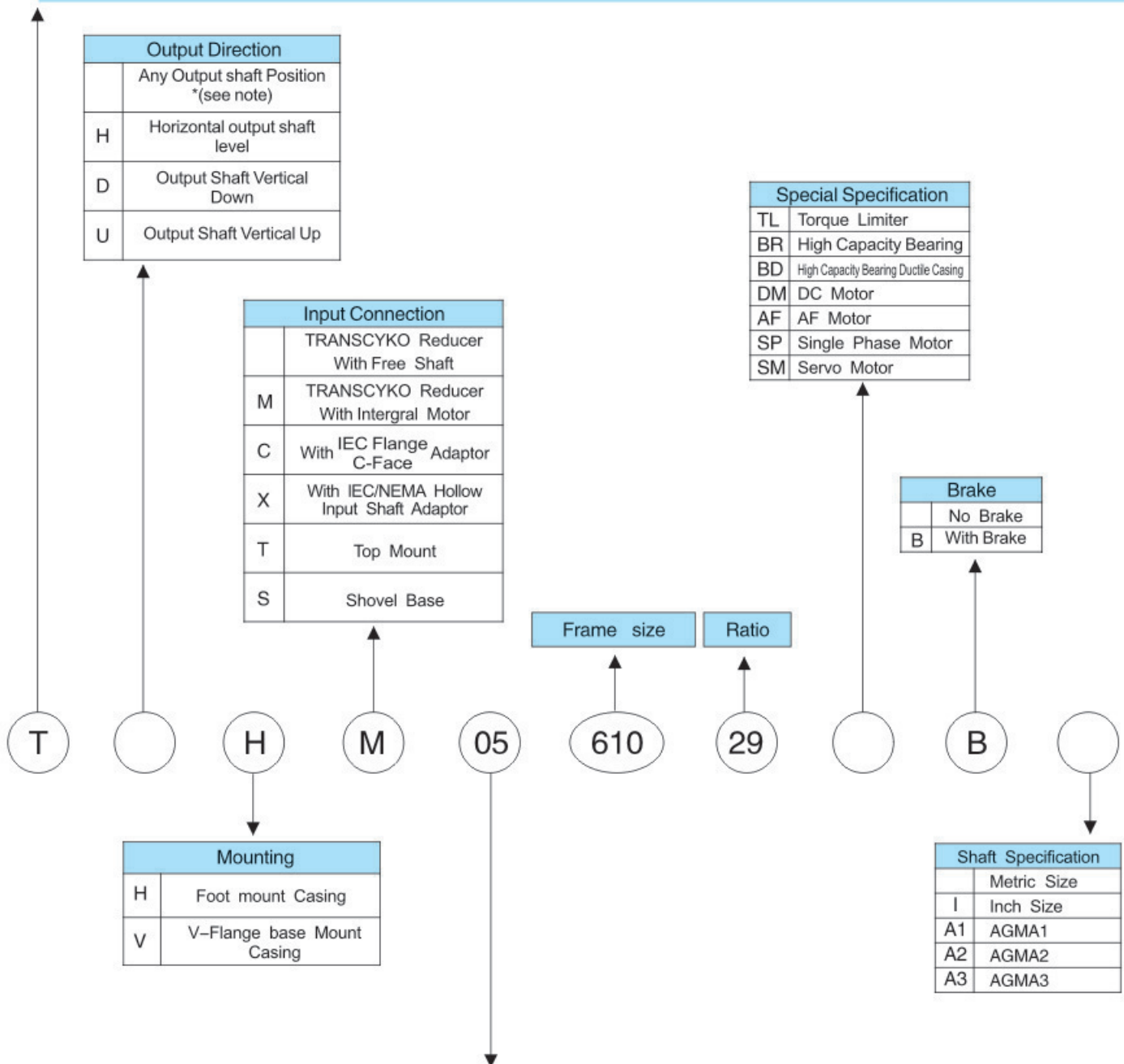

		Input Power–Motor Capacity Symbol																	
4 Pole	Symbol	02	05	1	2	3	5	8	10	15	20	25	30	40	50	60	75	100	
	KW	0.2	0.4	0.75	1.5	2.2	3.7	5.5	7.5	11	15	18.5	22	30	37	45	55	75	
	HP	1/4	1/2	1	2	3	5	7.5	10	15	20	25	30	40	50	60	75	100	
6 Pole	Symbol	20/6	25/6	30/6	40/6	50/6	60/6	75/6	100/6	125/6	150/6	175/6							
	KW	15	18.5	22	30	37	45	55	75	90	110	132							
	HP	20	25	30	40	50	60	75	100	125	150	175							

Note 1. Only grease lubricated maintenance-free TRANSCYKO Speed Reducers can be mounted in any position.

Note 2. Torque limiter is available upon request. Two models for selection: Spring-loaded limit switch model and load cell sensor. Refer to page 17 for details.

# MOUNTING POSITIONS

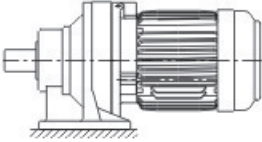
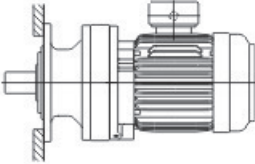
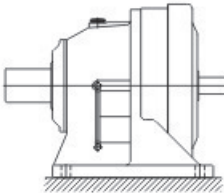
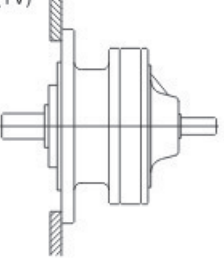
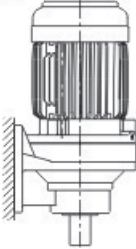
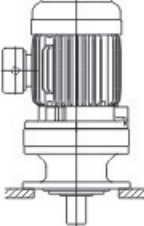
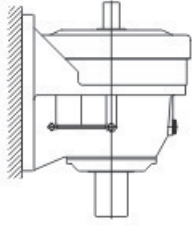
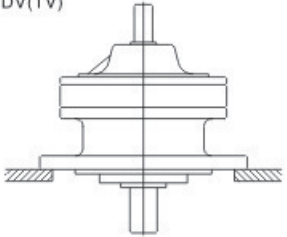
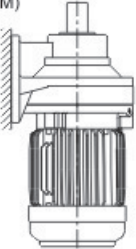
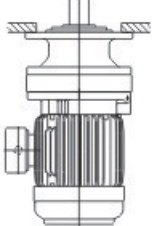
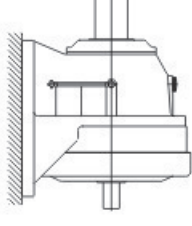
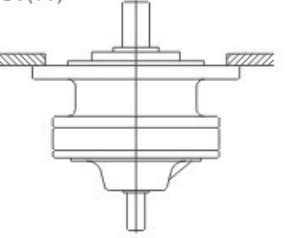
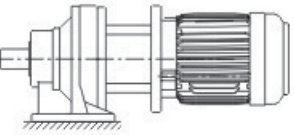
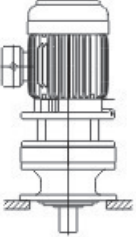
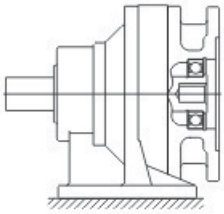
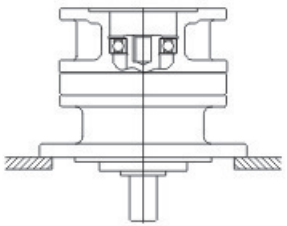
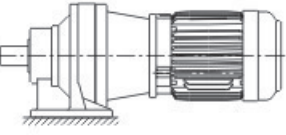
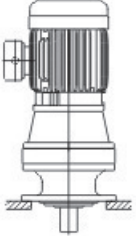
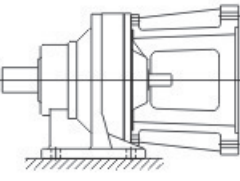
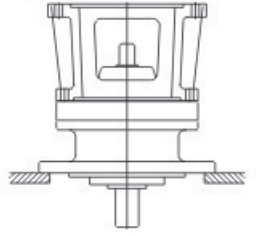
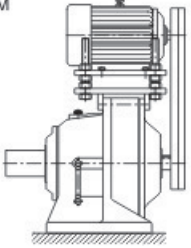
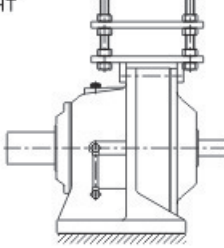
TRANSCYKO Gearmotors		TRANSCYKO Speed Reducers	
THHM(THM) 	THVM(TVM) 	THH(TH) 	THV(TV) 
TDHM(THM) 	TDVM(TVM) 	TDH(TH) 	TDV(TV) 
TUHM(THM) 	TUVM(TVM) 	TUH(TH) 	TUV(TV) 
TUHXM(THXM) 	TDVXM(TVXM) 	THHX(THX) 	TUVX(TVX) 
THHCM(THCM) 	TDVCM(TVCM) 	THHC(THC) 	TDVC(TVC) 
THHTM 		THHT 	



## LIST OF STANDARD FRAME SIZES

SINGLE STAGE	DOUBLE STAGE	OUTPUT FRAME SIZE	INPUT FRAME SIZE
607	607/07	607	607
608	608/07	608	607
609	609/08	609	608
610	610/08	610	608
611	611/08	611	608
612	611/09	611	609
613	613/08	613	608
614	613/09	613	609
615	613/10	613	610
616	614/08	614	608
617	614/09	614	609
618	614/10	614	610
619	616/09	616	609
620	616/10	616	610
621	616/11	616	611
622	617/09	617	609
623	617/10	617	610
624	617/11	617	611
625	618/10	618	610
626	618/13	618	613
627	619/11	619	611
	619/13	619	613
	620/11	620	611
	620/13	620	613
	621/13	621	613
	621/16	621	616
	622/13	622	613
	622/17	622	617
	623/16	623	616
	623/18	623	618
	624/16	624	616
	624/18	624	618
	625/17	625	617
	625/19	625	619
	626/19	626	619
	627/19	627	619

# COMBINATION OF RATIOS

1. Standard single stage reduction ratios with 4 pole motor (1500 R.P.M.-50HZ)  
(1800 R.P.M.-60HZ)

Ratio	6	8	11	13	15	17	21	25	29	35	43	51	59	71	87	119
Output 50Hz	250	188	136	115	100	88	71	60	52	43	35	29	25	21	17	13
Speed ( R.P.M) 60Hz	300	225	164	138	120	106	86	72	62	51	42	35	31	25	21	15

2. Standard single stage reduction ratios with 6 pole motor (1000 R.P.M.-50HZ)  
(1200 R.P.M.-60HZ)

Ratio	11	15	21	29	43	59	87
Output 50Hz	91	67	48	34	23	17	11
Speed ( R.P.M) 60Hz	109	80	57	41	28	20	14

3. Standard double stage reduction ratios with 4 pole motor (1500 R.P.M.-50HZ)  
(1800 R.P.M.-60HZ)

Ratio	104 (13x8)	121 (11x11)	143 (13x11)	165 (15x11)	195 (15x13)	231 (21x11)	273 (21x13)	319 (29x11)	377 (29x13)	473 (43x11)	559 (43x13)	649 (59x11)	731 (43x17)	841 (29x29)	1003 (59x17)
Output 50Hz	14	12	10	9.1	7.7	6.5	5.5	4.7	4.0	3.2	2.7	2.3	2.1	1.8	1.5
Speed ( R.P.M) 60Hz	17	15	13	11	9.2	7.8	6.6	5.6	4.8	3.8	3.2	2.8	2.5	2.1	1.8

Ratio	1247 (43x29)	1479 (87x17)	1849 (43x43)	2065 (59x35)	2537 (59x43)	3045 (87x35)	3481 (59x59)	4437 (87x51)	5133 (87x59)	6177 (87x71)	7569 (87x87)
Output 50Hz	1.2	1.0	0.81	0.73	0.59	0.49	0.43	0.34	0.29	0.24	0.20
Speed ( R.P.M) 60Hz	1.4	1.2	0.97	0.87	0.71	0.59	0.52	0.41	0.35	0.29	0.24

4. Other available double stage reduction ratios with 4 pole motor (1500 R.P.M.-50HZ)  
(1800 R.P.M.-60HZ)

Ratio	88 (11x8)	90 (15x6)	102 (17x6)	120 (15x8)	126 (21x6)	136 (17x8)	150 (25x6)	168 (21x8)	169 (13x13)	174 (29x6)	187 (17x11)	200 (25x8)	210 (35x6)	221 (17x13)	225 (15x15)
Output 50Hz	17	17	15	12	12	11	10	8.9	8.9	8.6	8.0	7.5	7.1	6.8	6.7
Speed ( R.P.M) 60Hz	20	20	18	15	14	13	12	11	11	10	9.6	9.0	8.6	8.1	8.0

Ratio	232 (29x8)	255 (17x15)	258 (43x6)	275 (25x11)	280 (35x8)	289 (17x17)	306 (51x6)	315 (21x15)	325 (25x13)	344 (43x8)	354 (59x6)	357 (21x17)	375 (25x15)	385 (35x11)	408 (51x87)
Output 50Hz	6.5	5.6	5.8	5.4	5.4	5.2	4.9	4.8	4.6	4.4	4.2	4.2	4.0	3.9	3.7
Speed ( R.P.M) 60Hz	7.8	7.0	7.0	6.5	6.4	6.2	5.9	5.7	5.5	5.2	5.1	5.0	4.8	4.7	4.4

Ratio	425 (25x17)	426 (71x6)	435 (29x15)	441 (21x21)	455 (35x13)	472 (59x8)	493 (29x17)	522 (87x6)	525 (35x15)	561 (51x11)	568 (71x8)	595 (35x17)	609 (29x21)	625 (25x25)	645 (43x15)
Output 50Hz	3.5	3.5	3.4	3.4	3.3	3.2	3.0	2.9	2.9	2.7	2.6	2.5	2.5	2.4	2.3
Speed ( R.P.M) 60Hz	4.2	4.2	4.1	4.1	4.0	3.8	3.7	3.4	3.4	3.2	3.2	3.0	3.0	2.9	2.8

Ratio	663 (51x13)	696 (87x8)	725 (29x25)	735 (35x21)	765 (51x15)	767 (59x13)	781 (71x11)	867 (51x17)	875 (35x25)	885 (59x15)	903 (43x21)	923 (71x13)	957 (87x11)	1015 (35x29)	1065 (71x15)
Output 50Hz	2.3	2.2	2.1	2.0	2.0	2.0	1.9	1.7	1.7	1.7	1.7	1.6	1.5	1.5	1.4
Speed ( R.P.M) 60Hz	2.7	2.6	2.5	2.4	2.4	2.3	2.3	2.1	2.1	2.0	2.0	2.0	1.8	1.8	1.7

Ratio	1071 (51x21)	1075 (43x25)	1131 (87x13)	1207 (71x17)	1225 (35x35)	1239 (59x21)	1275 (51x25)	1305 (87x15)	1475 (59x25)	149	155 (43x35)	1711 (59x29)	1775 (71x25)	1785 (51x35)	1827 (87x21)
Output 50Hz	1.4	1.4	1.3	1.2	1.2	1.2	1.2	1.1	1.0	1.0	1.0	0.88	0.85	0.84	0.82
Speed ( R.P.M) 60Hz	1.7	1.7	1.6	1.5	1.5	1.5	1.4	1.4	1.2	1.2	1.2	1.1	1.0	1.0	0.99

Ratio	2059 (71x29)	2175 (87x25)	2193 (51x43)	2485 (71x35)	2523 (87x29)	2601 (51x51)	3009 (59x51)	3053 (71x43)	3621 (71x51)	3741 (87x43)	4189 (71x59)	5041 (71x71)
Output 50Hz	0.73	0.69	0.68	0.60	0.59	0.58	0.50	0.49	0.41	0.40	0.36	0.30
Speed ( R.P.M) 60Hz	0.87	0.83	0.82	0.72	0.71	0.69	0.60	0.59	0.50	0.48	0.43	0.36



5. Available triple stage reduction ratios ( 1500 R.P.M.-50HZ )  
 ( 1800 R.P.M.-60HZ )

Ratio		990 (15x11x6)	1122 (17x11x6)	1331 (11x11x11)	1386 (21x11x6)	1734 (17x17x6)	1815 (15x11x11)	1914 (29x11x6)	2057 (17x11x11)	2142 (21x17x6)	2310 (35x11x6)
Output Speed (R.P.M.)	50Hz	1.5	1.3	1.1	1.1	0.86	0.83	0.78	0.73	0.70	0.65
	60Hz	1.8	1.6	1.4	1.3	1.0	0.99	0.94	0.87	0.84	0.78
Ratio		2541 (21x11x11)	2838 (43x11x6)	2958 (29x17x6)	3179 (17x17x11)	3509 (29x11x11)	3570 (35x17x6)	3894 (59x11x6)	3927 (21x17x11)	4235 (35x11x11)	4386 (43x17x6)
Output Speed (R.P.M.)	50Hz	0.59	0.53	0.51	0.47	0.43	0.42	0.38	0.38	0.35	0.34
	60Hz	0.71	0.63	0.61	0.57	0.51	0.50	0.46	0.46	0.42	0.41
Ratio		4913 (17x17x17)	5046 (29x29x6)	5203 (43x11x11)	5423 (29x17x11)	5742 (87x11x6)	6018 (59x17x6)	6069 (21x17x17)	6069 (35x29x6)	6545 (35x17x11)	7139 (59x11x11)
Output Speed (R.P.M.)	50Hz	0.30	0.30	0.29	0.28	0.26	0.25	0.25	0.25	0.23	0.21
	60Hz	0.37	0.36	0.34	0.33	0.31	0.30	0.30	0.30	0.28	0.25
Ratio		7350 (35x35x6)	7482 (43x29x6)	8041 (43x17x11)	8381 (29x17x17)	8874 (87x17x6)	9030 (43x35x6)	9251 (29x29x11)	10115 (35x17x17)	10266 (59x29x6)	10527 (87x11x11)
Output Speed (R.P.M.)	50Hz	0.20	0.20	0.19	0.18	0.17	0.17	0.16	0.15	0.15	0.14
	60Hz	0.24	0.24	0.22	0.21	0.20	0.20	0.19	0.18	0.18	0.17
Ratio		11033 (59x17x11)	11094 (43x43x6)	11165 (35x29x11)	12390 (59x35x6)	12427 (43x17x17)	13475 (35x35x11)	13717 (43x29x11)	14297 (29x29x17)	15138 (87x29x6)	15222 (59x43x6)
Output Speed (R.P.M.)	50Hz	0.14	0.14	0.13	0.12	0.12	0.11	0.11	0.10	0.10	0.10
	60Hz	0.16	0.16	0.16	0.14	0.14	0.13	0.13	0.12	0.12	0.12
Ratio		16269 (87x17x11)	16555 (43x35x11)	17051 (59x17x17)	17255 (35x29x17)	18270 (87x35x6)	18821 (59x29x11)	20339 (43x43x11)	20825 (35x35x17)	21199 (43x29x17)	22446 (87x43x6)
Output Speed (R.P.M.)	50Hz	0.09	0.09	0.09	0.09	0.08	0.08	0.07	0.07	0.07	0.07
	60Hz	0.11	0.11	0.10	0.10	0.10	0.10	0.09	0.09	0.08	0.08
Ratio		22715 (59x35x11)	24389 (29x29x29)	25143 (87x17x17)	25585 (43x35x17)	27753 (87x29x11)	27907 (59x43x11)	29087 (59x29x17)	29435 (35x29x29)	31433 (43x43x17)	33495 (87x35x11)
Output Speed (R.P.M.)	50Hz	0.07	0.06	0.06	0.06	0.05	0.05	0.05	0.05	0.05	0.04
	60Hz	0.08	0.07	0.07	0.07	0.06	0.06	0.06	0.06	0.06	0.05
Ratio		35105 (59x35x17)	35525 (35x35x29)	36163 (43x29x29)	38291 (59x59x11)	41151 (87x43x11)	42875 (35x35x35)	42891 (87x29x17)	43129 (59x43x17)	43645 (43x35x29)	49619 (59x29x29)
Output Speed (R.P.M.)	50Hz	0.04	0.04	0.04	0.04	0.04	0.03	0.03	0.03	0.03	0.03
	60Hz	0.05	0.05	0.05	0.05	0.04	0.04	0.04	0.04	0.04	0.04
Ratio		51765 (87x35x17)	52675 (43x35x35)	53621 (43x43x29)	56463 (87x59x11)	59177 (59x59x17)	59885 (59x35x29)	63597 (87x43x17)	64715 (43x43x35)	72275 (59x35x35)	73167 (87x29x29)
Output Speed (R.P.M.)	50Hz	0.03	0.03	0.03	0.03	0.02	0.02	0.02	0.02	0.02	0.02
	60Hz	0.03	0.03	0.03	0.03	0.03	0.03	0.03	0.03	0.02	0.02
Ratio		73573 (59x43x29)	79507 (43x43x43)	83259 (87x87x11)	87261 (87x59x17)	88305 (59x43x35)	88795 (59x43x35)	100949 (59x59x29)	106575 (87x35x35)	108489 (87x43x29)	109091 (59x43x43)
Output Speed (R.P.M.)	50Hz	0.02	0.02	0.02	0.02	0.02	0.02	0.01	0.01	0.01	0.01
	60Hz	0.02	0.02	0.02	0.02	0.02	0.02	0.02	0.02	0.02	0.02
Ratio		121835 (59x59x35)	128673 (87x87x17)	130935 (87x43x35)	148857 (87x59x29)	149863 (87x43x43)	160863 (87x43x43)	179655 (87x59x35)	205379 (59x59x59)	219501 (87x87x29)	220719 (87x59x43)
Output Speed (R.P.M.)	50Hz	0.01	0.01	0.01	0.01	0.01	0.01	0.01	0.01	0.01	0.01
	60Hz	0.01	0.01	0.01	0.01	0.01	0.01	0.01	0.01	0.01	0.01
Ratio		264915 (87x87x35)	302847 (87x59x59)	325467 (87x87x43)	446571 (87x87x59)	658503 (87x87x87)					
Output Speed (R.P.M.)	50Hz	0.006	0.005	0.005	0.003	0.002					
	60Hz	0.01	0.006	0.006	0.004	0.003					



# TORQUE LIMITER INDICATION

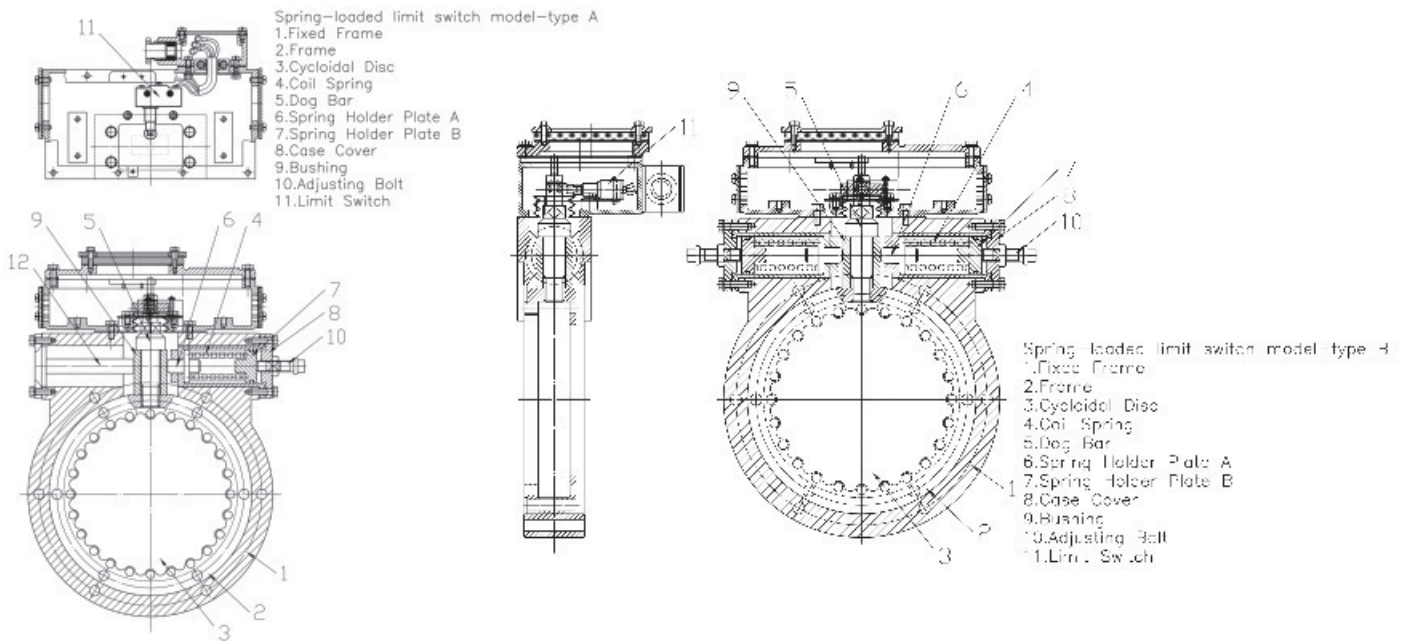

Type A: Load Factor (%) of the preset torque is indicated on the scale plate within 60 to 100% of the preset torque.

Type B: Load Factor (%) indicated on the scale plate ranges from 0 to 100% which enables the users to detect torque from no load to loaded conditions.

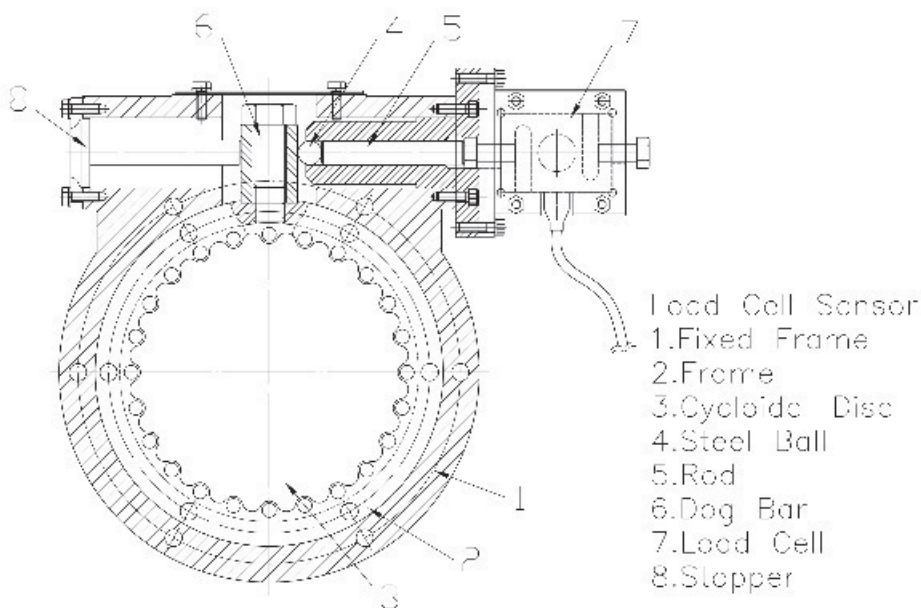

Electric analog signals responding to the load torque was generated by the cycloidal disc, transmitted through the frame, dog bar, steel ball, and rod. This mechanism transmits the torque directly to the load cell and thereby 0-100% of the load can be precisely obtained.

# HOW TO SELECT A SUITABLE TRANSCYKO GEARMOTOR

## Example 1

Given Conditions: 1. Driven machine application: Agitator (Liquids & Solids), output shaft vertical down, V-flange mounting  
2. Operation time: 24 hours/day  
3. Motor type: 4 pole, 50Hz, 1500 R.P.M.  
4. Required output speed: approximately 30 R.P.M.  
5. Transmitted Torque: 153 kg·m(13,280 in·lbs)

Step 1: Refer to "Machine Load Classifications", determine the machine load Characteristic = M.

And Operation time: 24 hrs/day

Review the "Recommended TRANSCYKO Load Factors" table, determine the load factor = 1.35

Step 2:  $P_1 \geq \frac{30 \times 153}{975} = 4.71 \text{ kw} \quad \therefore P_1 = 5.5 \text{ kw}$

Step 3: From the Selection Table on page 26, the closest ratio for required output speed 30 R.P.M. is 51 and unit frame size to suit transmitted torque 153 kg·m(13,280 in·lbs) [Output Torque 168kg·m(14,582 in·lbs)] and load factor 1.35[S.F=1.52] requirement is 617.

Step 4: The complete model designation would be TDVM8-617-51.

## Example 2

Given Conditions: 1. Driven machine application: Mixer (concrete), shaft coupling, output shaft vertical down  
2. Operation time: 10 hours/day  
3. Motor type: 4 pole, 60 Hz, 1800 R.P.M.  
4. Required output speed: approximately 15 R.P.M.  
5. Transmitted Torque: 150 kg·m(13,020 in·lbs)

Step 1: Refer to "Machine Load Classifications", determine the machine load Characteristic = M. And operation Time: 10 hour/day Review the "Recommended TRANSCYKO Load Factors" table, determine the load factor = 1.2

Step 2:  $P_1 \geq \frac{15 \times 150}{975} = 2.30 \text{ kw} \quad P_1 = 3.7 \text{ kw}$

Step 3: From the selection table on page 29, the closest ratio for required output speed 15 R.P.M. is 121. The load factor should be greater than 1.2 to determine the model designation. Considering motor type: 3.7 kW and 60 Hz, and output torque 150<204 kw, model TDVM5-617/11-121 was selected.

Step 4: The complete model designation would be TDVM5-617/11-121.



# SELECTION TABLE WITH 4 POLE MOTOR

Ratio	Frequency	Motor Input Speed	Reducer Output Speed
6	50 Hz	1500 R.P.M.	250 R.P.M.
	60 Hz	1800 R.P.M.	300 R.P.M.

MOTOR			50Hz			60Hz			TRANSCYKO MODEL	Dimension page	
KW	HP	SYMBOL	Output Torque kgf·m / in·lbs	Allowable Output Shaft Overhung load kgf / lbs	S.F.	Output Torque kgf·m / in·lbs	Allowable Output Shaft Overhung load kgf / lbs	S.F.		H	V
0.2	1/4	02	0.72/62	140/308	2.00	0.60/52	130/286	1.80	02-608-6	49	106
0.4	1/2	05	1.44/125	140/308	1.00	1.20/104	130/286	1.05	05-608-6	49	106
				262/576	3.32		248/546	3.35	05-609-6	50	107
0.75	1	1	2.70/234	262/576	1.77	2.25/195	248/546	1.79	1-609-6	50	107
				415/913	2.95		390/858	3.01	1-610-6	51	108
1.5	2	2	5.40/469	514/913	1.47	4.50/391	390/858	1.51	2-610-6	51	108
				516/1135	3.31		487/1071	3.25	2-611-6	52	109
2.2	3	3	7.92/687	415/913	1.00	6.60/573	390/858	1.03	3-610-6	51	108
				516/1135	2.25		487/1071	2.22	3-611-6	52	109
3.7	5	5	13.3/1156	516/1135	1.34	11.1/963	487/1071	1.32	5-611-6	52	109
				519/1142	1.79		487/1071	1.83	5-612-6	53	110
				601/1233	2.69		568/1250	2.69	5-613-6	54	111
5.5	7.5	8	19.8/1719	519/1142	1.20	16.5/1432	487/1071	1.23	8-612-6	53	110
				601/1322	1.81		568/1250	1.81	8-613-6	54	111
7.5	10	10	27.0/2344	601/1322	1.33	22.5/1953	568/1250	1.33	10-613-6	54	111
				1075/2365	2.24		1006/2213.2	2.24	10-615-6	56	113
				1130/2486	2.49		1065/2343	2.49	10-616-6	57	113
11	15	15	39.6/3437	952/2094.4	1.91	33.0/2864	901/1982.2	1.91	15-615-6	56	113
				1002/2204.4	2.06		971/2136.2	2.06	15-616-6	57	113
				1152/2534	1.94		1081/2378	3.21	15-617-6	58	114
15	20	20	54.0/4687	1152/2534	1.43	45.0/3906	1081/2378	2.60	20-617-6	58	114
18.5	25	25	66.6/5781	1152/2534	1.16	55.5/4817	1081/2378	1.85	25-617-6	58	114

Ratio	Frequency	Motor Input Speed	Reducer Output Speed
8	50 Hz	1500 R.P.M.	188 R.P.M.
	60 Hz	1800 R.P.M.	225 R.P.M.

MOTOR			50Hz			60Hz			TRANSCYKO MODEL	Dimension page	
KW	HP	SYMBOL	Output Torque kgf·m / in·lbs	Allowable Output Shaft Overhung load kgf / lbs	S.F.	Output Torque kgf·m / in·lbs	Allowable Output Shaft Overhung load kgf / lbs	S.F.		H	V
0.2	1/4	02	0.96/83	154/339	2.00	0.80/69	145/319	2.00	02-608-8	49	105
0.4	1/2	05	1.92/167	154/339	1.00	1.60/139	145/319	1.00	05-608-8	49	105
				289/636	3.38		272/598	3.35	05-608-8	50	106
0.75	1	1	3.60/312	289/636	1.80	3.00/260	272/598	1.79	1-609-8	50	106
				455/1001	3.63		429/944	3.68	1-610-8	51	107
1.5	2	2	7.20/625	455/1001	1.81	6.00/521	429/944	1.84	2-610-8	51	107
				570/1254	3.34		537/1181	3.34	2-611-8	52	108
2.2	3	3	10.6/917	455/1001	1.24	8.80/764	429/944	1.25	3-610-8	51	107
				570/1254	2.28		537/1181	2.28	3-611-8	52	108
3.7	5	5	17.8/1542	570/1254	1.36	14.8/1285	537/1181	1.35	5-611-8	52	108
				571/1256	1.84		540/1188	1.83	5-612-8	53	109
				659/1455	2.70		624/1373	2.70	5-613-8	54	110
5.5	7.5	8	26.4/2292	570/1258	1.24	22.0/1910	540/1188	1.23	8-612-8	53	109
				659/1450	1.82		624/1373	1.82	8-613-8	54	110
7.5	10	10	36.0/3125	659/1450	1.33	30.0/2604	624/1373	1.33	10-613-8	54	110
				1095/2409	2.24		1035/2277	2.24	10-615-8	56	112
				1160/2552	2.57		1098/2415.6	2.57	10-616-8	57	113
11	15	15	52.8/4583	1096/2411.2	1.94	44.0/3819	1025/2255	1.94	15-615-8	56	112
				1156/2543.2	2.12		1084/2384.8	2.12	15-616-8	57	113
15	20	20	72.0/6250	967/2127.4	1.15	60.0/5208	908/1997.6	1.15	20-615-8	56	112
				1007/2215.4	1.3		965/2123	1.3	20-616-8	57	113

\*Please select models in the shaded column when a load factor of 1.0 is required as shown on page 8.



Ratio	Frequency	Motor Input Speed	Reducer Output Speed
11	50 Hz	1500 R.P.M.	136 R.P.M.
	60 Hz	1800 R.P.M.	164 R.P.M.

MOTOR			50Hz			60Hz			TRANSCYKO MODEL	Dimension page	
KW	HP	SYMBOL	Output Torque kgf·m / in·lbs	Allowable Output Shaft Overhung load kgf / lbs	S.F.	Output Torque kgf·m / in·lbs	Allowable Output Shaft Overhung load kgf / lbs	S.F.		H	V
0.2	1/4	02	1.32/114	101/222	1.20	1.10/95	92/202	1.20	08-607-11	48	104
				170/374	2.00		161/354	2.00	02-608-11	49	105
0.4	1/2	05	2.64/229	170/374	1.00	2.20/191	161/354	1.00	05-608-11	49	105
				325/715	3.05		309/680	3.02	05-609-11	50	106
0.75	1	1	4.95/430	325/715	1.63	4.12/358	309/680	1.61	1-609-11	50	106
				506/1113	3.62		476/1047	3.60	1-610-11	51	107
1.5	2	2	9.90/859	506/1113	1.81	8.25/716	476/1047	1.80	2-610-11	51	107
				634/1395	3.35		597/1313	3.32	2-611-11	52	108
2.2	3	3	14.5/1259	506/1113	1.24	12.1/1050	476/1047	1.23	3-610-11	51	107
				634/1395	2.29		597/1313	2.26	3-611-11	52	108
3.7	5	5	24.4/2118	634/1395	1.36	20.4/1771	597/1313	1.34	5-611-11	52	108
				735/1617	2.62		692/1522	2.64	5-613-11	54	110
5.5	7.5	8	36.3/3151	735/1617	1.76	30.2/2626	692/1522	1.78	8-613-11	54	110
7.5	10	10	49.5/4297	735/1617	1.29	41.2/3576	962/1522	1.30	10-613-11	54	110
				968/2130	1.31		916/2015	1.32	10-614-11	55	111
				1205/2255	2.27		1170/2574	2.27	10-615-11	56	112
				1291/2840.2	2.56		1209/2659.8	2.56	10-616-11	5	113
11	15	15	72.6/6302	1212/2666.4	1.53	60.5/5251	1131/2488.2	1.53	15-615-11	56	112
				1291/2840.2	1.73		1222/2688.4	1.73	15-616-11	57	113
15	20	20	99.0/8593	1291/2636	1.27	85.5/7161	1222/2468	1.27	20-616-11	57	113
				1407/3095	1.80		1322/2908	1.79	20-617-11	58	114
				1888/4154	2.15		1780/3916	2.16	20-618-11	59	115
18.5	25	25	122/10590	1407/3095	1.46	102/8854	1322/2908	1.45	25-617-11	58	114
				1888/4154	1.74		1780/3916	1.75	25-618-11	59	115
22	30	30	145/12586	1407/3095	1.23	121/10503	1322/2908	1.22	30-617-11	58	114
				1888/4154	1.47		1780/3916	1.47	30-618-11	59	115
				2647/5823	1.97		1322/2908	1.97	30-619-11	60	116
30	40	40	198/17186	1888/4154	1.08	165/14322	1780/3916	1.08	40-618-11	59	115
				2647/5823	1.44		1322/2908	1.44	40-619-11	60	116
				3420/7524	1.92		1780/3916	1.93	40-620-11	61	117
37	50	50	244/21179	2647/5823	1.17	204/17707	2481/5458	1.17	50-619-11	60	116
				3420/7524	1.56		3242/7132	1.56	50-620-11	61	117
				4360/9625	1.89		2481/5485	1.88	50-621-11	62	118
45	60	60	297/25780	3420/7524	1.28	248/21526	3242/7132	1.28	60-620-11	61	117
				4367/9607	1.55		4132/9090	1.55	60-621-11	62	118
				4592/10102	2.14		3242/7132	2.13	60-622-11	63	119
55	75	75	363/31508	4367/9607	1.27	302/26214	4132/9090	1.26	75-621-11	62	118
				4592/10102	1.75		4350/9570	1.74	75-622-11	63	119
75	100	100	495/42966	4592/10102	1.29	412/35762	4350/9570	1.28	100-622-11	62	119

Ratio	Frequency	Motor Input Speed	Reducer Output Speed
13	50 Hz	1500 R.P.M.	115 R.P.M.
	60 Hz	1800 R.P.M.	138 R.P.M.

MOTOR			50Hz			60Hz			TRANSCYKO MODEL	Dimension page	
KW	HP	SYMBOL	Output Torque kgf·m / in·lbs	Allowable Output Shaft Overhung load kgf / lbs	S.F.	Output Torque kgf·m / in·lbs	Allowable Output Shaft Overhung load kgf / lbs	S.F.		H	V
0.2	1/4	02	1.56/135	107/235	1.20	1.30/113	100/220	1.20	02-607-13	48	104
				177/389	2.00		170/374	2.00	02-608-13	49	105
0.4	1/2	05	3.12/271	177/389	1.00	2.60/226	170/374	1.00	05-608-13	49	105
				334/735	3.00		325/715	3.00	05-609-13	50	106
0.75	1	1	5.85/508	334/735	1.60	4.88/424	325/715	1.60	1-609-13	50	106
				334/1175	3.54		505/1111	3.52	1-610-13	51	107
1.5	2	2	11.7/1016	534/1175	1.77	9.75/846	505/1111	1.76	2-610-13	51	107
				670/1474	3.25		634/1395	3.24	2-611-13	52	108

\*Please select models in the shaded column when a load factor of 1.0 is required as shown on page 8.



MOTOR			50Hz			60Hz			TRANSCYKO MODEL	Dimension page	
KW	HP	SYMBOL	Output Torque kgf·m / in·lbs	Allowable Output Shaft Overhung load kgf / lbs	S.F.	Output Torque kgf·m / in·lbs	Allowable Output Shaft Overhung load kgf / lbs	S.F.		H	V
2.2	3	3	17.2/1493	534/1175	1.21	14.3/1241	505/1111	1.20	3-610-13	51	107
				670/1474	2.22		634/1395	2.21	3-611-13	52	108
3.7	5	5	28.9/2508	670/1474	1.32	24.0/2083	634/1395	1.31	5-611-13	52	108
				670/1474	1.35		634/1395	1.35	5-612-13	53	109
				775/1705	2.49		736/1619	2.50	5-613-13	54	110
5.5	7.5	8	42.9/3724	775/1705	1.67	35.8/3107	736/1619	1.68	8-613-13	54	110
7.5	10	10	58.5/5078	775/1705	1.23	48.8/4236	736/1619	1.23	10-613-13	54	110
				1270/2794	2.27		1212/2666.4	2.27	10-615-13	56	112
				1365/3003	2.57		1303/2866.6	2.57	10-616-13	57	113
11	15	15	85.8/7447	1256/2763.2	1.53	71.5/6206	1193/2624.6	1.53	15-615-13		
				1362/2996.4	1.74		1295/2849	1.74	15-616-13	57	113
				1478/3252	2.43		1407/3095	2.44	15-617-13	58	114
15	20	20	117/10156	1342/2952.4	1.74	97.5/8463	1271/2796.2	1.25	20-616-13	57	113
				1478/3252	1.78		1407/3095	1.79	20-617-13	58	114
				1995/4389	2.21		1884/4145	2.20	20-618-13	59	115
18.5	25	25	144/12499	1478/3252	1.44	120/10416	1407/3095	1.45	25-617-13	58	114
				1995/4389	1.79		1884/4145	1.78	25-618-13	59	115
22	30	30	172/14930	1478/3252	1.21	143/12412	1407/3095	1.22	30-617-13	58	114
				1995/4389	1.50		1884/4145	1.50	30-618-13	59	115
				2793/6145	1.81		2632/5790	1.92	30-619-13	60	116
30	40	40	234/20311	1995/4389	1.10	195/16926	1884/4145	1.10	40-618-13	59	115
				2793/6145	1.33		2632/5790	1.41	40-619-13	60	116
37	50	50	289/25085	2791/6145	1.08	241/20919	2632/5790	1.14	50-619-13	60	116

Ratio	Frequency	Motor Input Speed	Reducer Output Speed
15	50 Hz	1500 R.P.M.	100 R.P.M.
	60 Hz	1800 R.P.M.	120 R.P.M.

MOTOR			50Hz			60Hz			TRANSCYKO MODEL	Dimension page	
KW	HP	SYMBOL	Output Torque kgf·m / in·lbs	Allowable Output Shaft Overhung load kgf / lbs	S.F.	Output Torque kgf·m / in·lbs	Allowable Output Shaft Overhung load kgf / lbs	S.F.		H	V
0.2	1/4	0.2	1.80/156	110/242	1.20	1.50/130	106/233	1.20	02-607-15	48	104
				180/396	2.00		179/394	2.00	02-608-15	49	105
0.4	1/2	0.5	3.60/312	180/396	1.00	3.00/260	179/394	1.00	05-608-15	49	105
				340/748	2.62		335/737	2.00	05-609-15	50	106
0.75	1	1	6.75/586	340/748	1.40	5.62/488	335/737	1.39	1-609-15	50	106
				550/1210	3.65		528/1162	3.63	1-610-15	51	107
1.5	2	2	13.5/1161	550/1210	1.83	11.3/981	528/1162	1.81	2-610-15	51	107
				705/1551	3.23		662/1456	3.21	2-611-15	52	108
2.2	3	3	19.8/1719	550/1210	1.24	16.5/1432	528/1162	1.24	3-610-15	51	107
				705/1551	2.20		662/1456	2.19	3-611-15	52	108
3.7	5	5	33.3/2890	705/1551	1.31	27.8/2413	662/1456	1.30	5-611-15	52	108
				705/1551	1.34		662/1456	1.34	5-612-15	53	109
				818/1799	2.06		765/1683	2.05	5-613-15	54	110
5.5	7.5	8	49.5/4297	818/1799	1.39	41.2/3576	765/1683	1.38	8-613-15	54	110
				1060/2332	1.66		1010/2222	1.66	8-614-15	55	111
7.5	10	10	67.5/5859	818/1799	1.02	56.2/4878	765/1683	1.01	10-613-15	54	110
				1060/2332	1.22		1010/2222	1.22	10-614-15	55	111
				1334/2934.8	2.14		1281/2818.2	2.14	10-615-15	56	112
				1460/3212	2.43		1380/3036	2.43	10-616-15	57	113
11	15	15	99.0/8593	1332/2930.4	1.47	82.5/7161	1264/2780.8	1.48	15-615-15		
				1441/3170.2	1.64		1348/2965.6	1.64	15-616-15	57	113
				1565/3443	2.08		1470/3234	2.07	20-617-15	58	114
15	20	20	135/11718	1421/3126.2	1.21	113/9808	1341/2950.2	1.21	20-616-15	57	113
				1565/3443	1.53		1470/3234	1.52	20-617-15	58	114
				2100/4620	2.02		1970/4334	2.00	20-618-15	59	115
18.5	25	25	167/14496	1565/3443	1.24	139/12065	1470/3234	1.23	25-617-15	58	114
				2100/4620	1.64		1970/4334	1.62	25-618-15	59	115
22	30	30	198/17186	1565/3443	1.04	165/14322	1470/3234	1.04	30-617-15	58	114
				2100/4620	1.38		1970/4334	1.36	30-618-15	59	115
				2940/6468	1.94		2750/6050	1.93	30-619-15	60	116



MOTOR			50Hz			60Hz			TRANSCYKO MODEL	Dimension page	
KW	HP	SYMBOL	Output Torque kgf·m / in·lbs	Allowable Output Shaft Overhung load kgf / lbs	S.F.	Output Torque kgf·m / in·lbs	Allowable Output Shaft Overhung load kgf / lbs	S.F.		H	V
30	40	40	270/23436	2090/4614	1.01	225/19530	1970/4334	1.01	40-618-15	59	115
				2930/6468	1.42		2750/6050	1.42	40-619-15	59	115
				3760/8300	1.94		3560/7832	1.94	40-620-15	61	117
37	50	50	333/28904	2930/6468	1.15	278/24130	2750/6050	1.15	50-619-15	60	116
				3760/8300	1.57		3560/7832	1.57	50-620-15	61	117
				4790/10574	1.93		4530/10000	1.93	50-621-15	62	118
45	60	60	405/35154	3760/8300	1.29	338/29338	3560/7830	1.29	60-620-15	61	117
				4790/10574	1.58		4530/9966	1.58	60-621-15	62	118
				5040/11126	2.00		4770/10494	2.00	60-622-15	63	119
55	75	75	495/42966	4790/10574	1.30	412/35762	4530/9966	1.30	75-621-15	62	118
				5040/11126	1.64		4770/10494	1.64	75-622-15	63	119
75	100	100	675/58590	5040/11126	1.20	562/48782	4770/10494	1.20	100-622-15	63	119

Ratio	Frequency	Motor Input Speed	Reducer Output Speed
17	50 Hz	1500 R.P.M.	88 R.P.M.
	60 Hz	1800 R.P.M.	106 R.P.M.

MOTOR			50Hz			60Hz			TRANSCYKO MODEL	Dimension page	
KW	HP	SYMBOL	Output Torque kgf·m / in·lbs	Allowable Output Shaft Overhung load kgf / lbs	S.F.	Output Torque kgf·m / in·lbs	Allowable Output Shaft Overhung load kgf / lbs	S.F.		H	V
0.2	1/4	02	2.04/177	110/242	1.20	1.72/149	109/240	1.20	02-607-17	48	104
				180/396	2.00		179/394	2.00	02-608-17	49	105
0.4	1/2	05	4.08/354	180/396	1.00	3.40/295	179/394	1.00	05-608-17	49	105
				340/748	2.68		339/746	2.72	05-609-17	50	106
0.75	1	1	7.65/664	340/748	1.43	6.38/554	339/746	1.45	1-609-17	50	106
				550/1210	2.79		550/1210	2.73	1-610-17	51	107
1.5	2	2	15.3/1328	550/1210	1.39	12.8/1111	550/1210	1.37	2-610-17	51	107
				733/1613	3.12		690/1518	3.07	2-611-17	52	108
2.2	3	3	22.4/1944	733/1613	2.13	18.7/1623	690/1518	2.09	3-611-17	52	108
				733/1613	1.26		690/1518	1.24	5-611-17	52	108
3.7	5	5	37.7/3272	734/1615	1.34	31.4/2726	690/1518	1.34	5-612-17	53	109
				850/1870	1.90		795/1749	1.91	5-613-17	54	110
5.5	7.5	7.5	56.1/4869	850/1870	1.28	46.8/4062	795/1749	1.28	8-613-17	54	110
				1100/2420	1.65		1040/2288	1.64	8-614-17	55	111
7.5	10	10	76.5/6640	1100/2420	1.21	63.8/5538	1040/2288	1.20	10-614-17	55	111
				1389/3055.8	1.64		1321/2906.2	1.64	10-615-17		
				1380/3036	2.00		1310/2882	1.99	10-616-17	57	113
11	15	15	112/9722	1487/3271.4	1.35	93.5/8116	1401/3082.2	1.35	15-616-17	57	113
				1620/3564	1.75		1532/3370	1.75	15-617-17	58	114
15	20	20	153/13280	1460/3212	1.21	128/11110	1380/3036	1.21	20-616-17	57	113
				1620/3564	1.29		1532/3370	1.29	20-617-17	58	114
				2180/4796	2.00		2050/4510	1.99	20-168-17	59	115
18.5	25	25	189/16405	1620/3564	1.04	157/13628	1532/3370	1.04	25-617-17	58	114
				2180/4796	1.62		2050/4510	1.61	25-618-17	59	115
22	30	30	224/19443	2180/4796	1.36	188/16339	2050/4510	1.35	30-618-17	59	115
				3050/6710	1.95		2870/6314	1.94	30-619-17	60	116
30	40	40	306/26561	2180/4796	1.00	255/22134	2050/4510	1.00	40-618-17	59	115
				3050/6710	1.43		2870/6314	1.42	40-619-17	60	116
37	50	50	377/32724	3050/6710	1.16	314/27255	2870/6314	1.15	50-619-17	60	116

Ratio	Frequency	Motor Input Speed	Reducer Output Speed
21	50 Hz	1500 R.P.M.	71 R.P.M.
	60 Hz	1800 R.P.M.	89 R.P.M.

MOTOR			50Hz			60Hz			TRANSCYKO MODEL	Dimension page	
KW	HP	SYMBOL	Output Torque kgf·m / in·lbs	Allowable Output Shaft Overhung load kgf / lbs	S.F.	Output Torque kgf·m / in·lbs	Allowable Output Shaft Overhung load kgf / lbs	S.F.		H	V
0.2	1/4	02	2.52/219	110/242	1.00	2.10/182	110/242	1.00	02-607-21	48	104

\*Please select models in the shaded column when a load factor of 1.0 is required as shown on page 8.



MOTOR			50Hz			60Hz			TRANSCYKO MODEL	Dimension page	
KW	HP	SYMBOL	Output Torque kgf·m / in·lbs	Allowable Output Shaft Overhung load kgf / lbs	S.F.	Output Torque kgf·m / in·lbs	Allowable Output Shaft Overhung load kgf / lbs	S.F.		H	V
0.2	1/4	02	2.52/219	180/396	2.00	2.10/182	180/396	2.00	02-608-21	49	105
0.4	1/2	05	5.04/437	180/396	1.00	4.20/364	180/396	1.00	05-608-21	49	105
				340/748	2.48		340/748	2.50	05-609-21	50	106
0.75	1	1	9.45/820	340/748	1.32	7.88/684	340/748	1.33	1-609-21	50	106
				550/1210	2.69		550/1210	2.68	1-610-21	51	107
1.5	2	2	18.9/1640	550/1210	1.35	15.8/1371	550/1210	1.34	2-610-21	51	107
				787/1731	2.69		740/1628	2.67	2-611-21	52	108
2.2	3	3	27.7/2413	787/1731	1.83	23.1/2005	740/1628	1.82	3-611-21	52	108
3.7	5	5	46.6/4046	787/1731	1.09	38.8/3368	740/1628	1.08	5-611-21	52	108
				909/2000	1.64		855/1881	1.63	5-613-21	54	110
5.5	7.5	8	69.3/6015	909/2000	1.10	57.8/5017	855/1881	1.09	8-613-21	54	110
				1180/2596	1.22		1110/2442	1.21	8-614-21	55	111
				1509/3319.8	1.98		1410/3102	1.98	8-615-21		
				1634/3594.8	2.3		1535/3377	2.3	8-616-21	57	113
7.5	10	10	94.5/8203	1495/3289	1.88	78.8/6840	1415/3113	1.88	10-615-21		
				1568/3449.6	2.08		1524/3352.8	2.08	10-616-21	57	113
11	15	15	139/12065	1585/3487	1.12	116/10069	1455/3201	1.08	15-616-21	57	113
				1740/3828	1.68		1640/3608	1.67	15-617-21	58	114
15	20	20	189/16405	1740/3828	1.23	158/13714	1640/3608	1.23	20-617-54	58	114
				2340/5148	1.79		2200/4840	1.79	20-618-21	59	115
18.5	25	25	233/20224	1740/3828	1.00	194/16839	1640/3608	1.00	25-617-21	58	114
				2340/5148	1.45		2200/4840	1.45	25-618-21	59	115
				3270/7194	1.95		3080/6776	1.96	25-619-21	60	116
22	30	30	277/24044	2340/5148	1.22	231/20051	2200/4840	1.22	30-618-21	59	115
				3270/7194	1.64		3080/6776	1.64	30-619-21	60	116
30	40	40	378/32810	3270/7194	1.20	315/27342	3080/6776	1.21	40-619-21	60	116
				4160/9152	1.54		3940/8668	1.53	40-620-21	61	117
				5300/11660	1.98		5010/11022	1.98	40-621-21	62	118
37	50	50	466/40449	3270/7194	1.00	388/33687	3080/6776	1.00	50-619-21	60	116
				4160/9152	1.25		3940/8668	1.24	50-620-21	61	117
				5300/11660	1.93		5010/11022	1.92	50-621-21	62	118
				5580/12276	2.44		5280/11616	2.43	50-622-21	63	119
45	60	60	567/49216	4160/9152	1.03	427/40970	3940/8668	1.02	60-620-21	61	117
				5300/11660	1.58		5010/11022	1.58	60-621-21	62	118
				5580/12276	2.00		5280/11616	2.00	60-622-21	63	119
55	75	75	693/60152	5300/11660	1.30	578/50170	5010/11022	1.29	75-621-21	62	118
				5580/12276	1.64		5280/11616	1.64	75-622-21	63	119

Ratio	Frequency	Motor Input Speed	Reducer Output Speed
25	50 Hz	1500 R.P.M.	60 R.P.M.
	60 Hz	1800 R.P.M.	72 R.P.M.

MOTOR			50Hz			60Hz			TRANSCYKO MODEL	Dimension page	
KW	HP	SYMBOL	Output Torque kgf·m / in·lbs	Allowable Output Shaft Overhung load kgf / lbs	S.F.	Output Torque kgf·m / in·lbs	Allowable Output Shaft Overhung load kgf / lbs	S.F.		H	V
0.2	1/4	02	3.00/260	180/396	1.25	2.50/217	180/396	1.25	02-608-25	49	105
				340/748	3.78		340/748	3.75	02-609-25	50	106
0.4	1/2	05	6.00/521	340/748	1.88	5.00/434	340/748	1.88	05-609-25	50	106
				340/748	1.00		340/748	1.00	1-609-25	50	106
0.75	1	1	11.3/981	550/1210	1.92	9.38/814	550/1210	1.96	1-610-25	51	107
				835/1837	2.13		785/1727	2.13	2-611-25	52	108
2.2	3	3	33.0/2864	835/1837	1.45	27.5/2387	785/1727	1.45	3-611-25	52	108
				835/1837	1.52		785/1727	1.52	3-612-25	53	109
				965/2123	2.31		909/2000	2.31	3-613-25	54	110
3.7	5	5	55.5/4817	965/2123	1.37	46.2/4010	909/2000	1.37	5-613-25	54	110
				1242/2732	1.58		1170/2574	1.57	5-614-25	55	111
5.5	7.5	8	82.5/7161	1242/2732	1.06	68.8/5972	1170/2574	1.06	8-614-25	55	111
				1577/3469.4	1.57		1478/3251.6	1.57	8-615-25	56	112
				1687/3711.4	1.75		1606/3533.2	1.75	8-616-25	57	113
7.5	10	10	113/9808	1547/3403.4	1.14	93.8/8142	1476/3247.2	1.14	10-615-25	56	112
				1669/3671.8	1.28		1594/3506.8	1.28	10-616-25	57	113
				1855/4081	2.07		1740/3828	2.08	10-617-25	58	114

\*Please select models in the shaded  column when a load factor of 1.0 is required as shown on page 8.



MOTOR			50Hz			60Hz			TRANSCYKO MODEL	Dimension page	
KW	HP	SYMBOL	Output Torque kgf·m / in·lbs	Allowable Output Shaft Overhung load kgf / lbs	S.F.	Output Torque kgf·m / in·lbs	Allowable Output Shaft Overhung load kgf / lbs	S.F.		H	V
11	15	15	165/14322	1656/3643.2	1.19	138/11978	1551/3412.2	1.32	15-616-25	57	113
				1855/4081	1.41		1740/3828	1.42	15-617-25	58	114
				2490/5478	2.07		2330/5126	2.07	15-618-25	59	115
15	20	20	225/19530	1855/4081	1.03	188/16318	1740/3828	1.04	20-617-25	58	114
				2490/5478	1.52		2330/5123	1.52	20-618-25	59	115
				3490/7678	2.29		3260/7172	2.28	20-619-25	60	116
18.5	25	25	278/24130	2490/5478	1.23	231/20051	2330/5126	1.23	25-618-25	59	115
				3490/7678	1.86		3260/7172	1.85	25-619-25	60	116
22	30	30	330/28644	2490/5478	1.04	275/23870	2330/5126	1.04	30-618-25	59	115
				3490/7678	1.56		3260/7172	1.55	30-619-25	60	116
30	40	40	450/39060	3490/7678	1.15	375/32550	2360/7172	1.14	40-619-25	60	116

Ratio	Frequency	Motor Input Speed	Reducer Output Speed
29	50 Hz	1500 R.P.M.	52 R.P.M.
	60 Hz	1800 R.P.M.	62 R.P.M.

MOTOR			50Hz			60Hz			TRANSCYKO MODEL	Dimension page	
KW	HP	SYMBOL	Output Torque kgf·m / in·lbs	Allowable Output Shaft Overhung load kgf / lbs	S.F.	Output Torque kgf·m / in·lbs	Allowable Output Shaft Overhung load kgf / lbs	S.F.		H	V
0.2	1/4	02	3.48/302	180/396	1.20	2.90/252	180/396	1.20	02-608-29	49	105
				340/748	3.35		340/748	3.40	02-609-29	50	106
0.4	1/2	05	6.96/604	340/748	1.68	5.80/503	340/748	1.70	05-609-29	50	106
0.75	1	1	13.0/1128	550/1210	1.84	10.9/944	550/1210	1.84	1-610-29	51	107
1.5	2	2	26.1/2265	876/1927	1.90	21.8/1892	824/1813	1.89	2-611-29	52	108
				876/1927	1.30		824/1813	1.29	3-611-29	52	108
2.2	3	3	38.3/3324	1010/2222	2.00	31.9/2769	954/2100	2.00	3-613-29	54	110
				1010/2222	1.19		954/2100	1.19	5-613-29	54	110
3.7	5	5	64.4/5590	1300/2860	1.39	53.6/4652	1230/2706	1.31	5-614-29	55	111
				1625/3575	2.24		1536/3379.2	2.24	5-615-29	56	112
				1775/3905	2.53		1679/3693.8	2.53	5-616-29	57	113
				1612/3546.4	1.52		1523/3350.6	1.52	8-615-29	56	112
5.5	7.5	8	95.7/8307	1756/3863.2	1.71	79.8/6927	1657/3645.4	1.71	8-616-29	57	113
				1667/3667.4	1.28		1596/3511.2	1.28	10-616-29	57	113
7.5	10	10	131/11371	1940/4268	1.91	109/9461	1830/4026	1.91	10-617-29	58	114
				1940/4268	1.30		1830/4026	1.30	15-617-29	58	114
11	15	15	191/16579	2610/5742	1.67	160/13888	2458/5408	1.66	15-618-29	59	115
				2610/5742	1.23		2458/5408	1.22	20-618-29	59	115
15	20	20	261/22655	3650/8030	2.01	218/18922	3430/7546	2.00	20-619-29	60	116
				2610/5742	1.00		2458/5408	1.00	25-618-29	59	115
18.5	25	25	322/27950	3650/8030	1.63	268/23262	3430/7546	1.62	25-619-29	60	116
				4580/10076	2.11		4340/9548	2.11	25-620-29	61	117
				3650/8030	1.37		3430/7546	1.36	30-619-29	60	116
22	30	30	383/33244	4580/10076	1.78	319/27689	4340/9548	1.77	30-620-29	61	117
				3650/8030	1.00		3430/7546	1.00	40-619-29	60	116
30	40	40	522/45310	4580/10076	1.34	435/3758	4340/9548	1.30	40-620-29	61	117
				5860/12892	1.59		5539/12185	1.59	40-621-29	62	118
				6161/13554	1.78		5820/12804	1.78	40-622-29	63	119
				4580/10076	1.06		4340/9548	1.05	50-620-29	61	117
37	50	50	644/55899	5860/12892	1.29	536/46525	5539/12185	1.29	50-621-29	62	118
				6161/13554	1.44		5820/12804	1.44	50-622-29	63	119
45	60	60	783/67964	5860/12892	1.06	652/56594	5539/12185	1.06	60-621-29	62	118
				6161/13554	1.19		5820/12804	1.18	60-622-29	63	119
55	75	75	957/83068	6161/13554	1.00	798/69266	5820/12804	1.00	75-622-29	63	119

\*Please select models in the shaded column when a load factor of 1.0 is required as shown on page 8.



Ratio	Frequency	Motor Input Speed	Reducer Output Speed
35	50 Hz	1500 R.P.M.	43 R.P.M.
	60 Hz	1800 R.P.M.	51 R.P.M.

MOTOR			50Hz			60Hz			TRANSCYKO MODEL	Dimension page	
KW	HP	SYMBOL	Output Torque kgf·m / in·lbs	Allowable Output Shaft Overhung load kgf / lbs	S.F.	Output Torque kgf·m / in·lbs	Allowable Output Shaft Overhung load kgf / lbs	S.F.		H	V
0.2	1/4	02	4.20/364	180/396	1.20	3.50/304	180/396	1.20	02-608-35	49	105
				340/748	2.90		340/748	2.90	02-609-35	50	106
0.4	1/2	05	8.40/729	340/748	1.45	7.00/608	340/748	1.45	05-609-35	50	106
				550/1210	2.55		550/1210	2.58	05-610-35	51	107
0.75	1	1	15.8/1371	550/1210	1.36	13.1/1137	550/1210	1.37	1-610-35	51	107
				880/1936	3.23		880/1936	3.20	1-611-35	52	108
1.5	2	2	31.5/2734	880/1936	1.61	26.2/2274	880/1936	1.60	2-611-35	52	108
				1080/2376	2.43		1080/2376	2.41	2-613-35	54	110
2.2	3	3	46.2/4010	880/1936	1.10	38.5/3342	880/1936	1.09	3-611-35	52	108
				1080/2376	1.65		1080/2376	1.64	3-613-35	54	110
3.7	5	5	77.7/6744	1080/2376	1.00	64.8/5625	1080/2376	1.00	5-613-35	54	110
				1370/3014	1.25		1370/3014	1.24	5-614-35	55	111
				1731/3808.2	1.87		1635/3597	2.15	5-615-35	56	112
				1885/4147	2.1		1775/3905	2.51	5-616-35	57	113
5.5	7.5	8	116/10069	1750/3850	1.57	96.2/8350	1750/3850	1.56	8-616-35	57	113
				2077/4570	2.27		2077/4570	2.25	8-617-35	58	114
7.5	10	10	158/13714	1750/3850	1.15	131/11371	1750/3850	1.15	10-616-35	57	113
				2077/4570	1.67		2077/4570	1.65	10-617-35	58	114
11	15	15	231/20051	2077/4570	1.14	193/16752	2077/4570	1.13	15-617-35	58	114
				2773/6101	1.68		2773/6101	1.67	15-618-35	59	115
15	20	20	315/27342	2773/6101	1.23	262/22742	2773/6101	1.23	20-618-35	59	115
				3880/8536	1.58		3880/8536	1.57	20-619-35	60	116
18.5	25	25	389/33765	2773/6101	1.00	324/28123	2773/6101	1.00	25-618-35	59	115
				3880/8536	1.28		3880/8536	1.27	25-619-35	60	116
22	30	30	462/40102	3880/8536	1.08	385/33418	3880/8536	1.07	30-619-35	60	116

Ratio	Frequency	Motor Input Speed	Reducer Output Speed
43	50 Hz	1500 R.P.M.	35 R.P.M.
	60 Hz	1800 R.P.M.	42 R.P.M.

MOTOR			50Hz			60Hz			TRANSCYKO MODEL	Dimension page	
KW	HP	SYMBOL	Output Torque kgf·m / in·lbs	Allowable Output Shaft Overhung load kgf / lbs	S.F.	Output Torque kgf·m / in·lbs	Allowable Output Shaft Overhung load kgf / lbs	S.F.		H	V
0.2	1/4	02	5.16/448	180/396	1.00	4.30/373	180/396	1.00	02-608-43	49	105
				340/748	2.50		340/748	2.45	02-609-43	50	106
0.4	1/2	05	10.3/894	340/748	1.25	8.60/746	340/748	1.22	05-609-43	50	106
				550/1210	2.32		550/1210	2.32	05-610-43	51	107
0.75	1	1	19.4/1684	550/1210	1.24	16.1/1397	550/1210	1.24	1-610-43	51	107
				880/1936	2.56		880/1936	2.56	1-611-43	52	108
1.5	2	2	38.7/3359	880/1936	1.28	32.2/2795	880/1936	1.28	2-611-43	52	108
				1150/2530	1.97		1094/2406	1.97	2-613-43	54	110
2.2	3	3	56.8/4930	1150/2530	1.34	47.3/4106	1094/2406	1.34	3-613-43	54	110
				1460/3212	1.44		1380/3036	1.43	3-614-43	55	111
				1810/3982	2.44		1741/3830.2	2.83	3-615-43	56	112
3.7	5	5	95.5/8289	1813/3988.6	1.45	79.6/6909	1727/3799.4	1.68	5-615-43	56	112
				2018/4439.6	1.71		1894/4166.8	1.95	5-616-43	57	113
5.5	7.5	8	142/12326	1880/4136	1.23	118/10242	1776/3907	1.22	8-616-43	57	113
				2220/4884	1.69		2087/4592	1.68	8-617-43	58	114
7.5	10	10	194/16839	2220/4884	1.24	161/13975	2087/4592	1.24	10-617-43	58	115
				2983/6567	2.00		2800/6160	1.97	10-618-43	59	115
11	15	15	284/24651	2983/6567	1.36	237/20572	2800/6160	1.34	15-618-43	59	115
				4150/9130	1.86		3910/8602	1.89	15-619-43	60	116
15	20	20	387/33592	2985/6567	1.00	323/28036	2800/6160	1.00	20-618-43	59	115
				4150/9130	1.37		3910/8602	1.39	20-619-43	60	116

\*Please select models in the shaded column when a load factor of 1.0 is required as shown on page 8.



MOTOR			50Hz			60Hz			TRANSCYKO MODEL	Dimension page	
KW	HP	SYMBOL	Output Torque kgf·m / in·lbs	Allowable Output Shaft Overhung load kgf / lbs	S.F.	Output Torque kgf·m / in·lbs	Allowable Output Shaft Overhung load kgf / lbs	S.F.		H	V
15	20	20	387/33592	5150/11330	1.82	323/28036	4897/10773	1.80	20-620-43	61	117
	25	25	477/41404	4150/9130	1.11	398/34546	3910/8602	1.12	25-619-43	60	116
				5150/11330	1.48		4897/10773	1.46	25-620-43	61	117
				6565/14443	2.02		6220/13684	2.00	25-621-43	62	118
	30	30	568/49302	5150/11330	1.24	473/41056	4897/10733	1.23	30-620-43	61	117
				6565/14443	1.70		6220/13684	1.69	30-621-43	62	118
				6910/15202	2.08		6562/14437	2.08	30-622-43	63	119
	40	40	774/67183	6565/14443	1.24	645/55986	6220/13684	1.24	40-621-43	62	118
				6910/15202	1.52		6562/14437	1.52	40-622-43	63	119
	50	50	955/82894	6565/14443	1.01	796/69093	6220/13684	1.00	50-621-43	62	118
				6910/15202	1.24		6562/14437	1.24	50-622-43	63	119
45	60	60	1161/100775	6910/15202	1.02	968/84022	6562/14437	1.02	60-622-43	63	119

Ratio	Frequency	Motor Input Speed	Reducer Output Speed
51	50 Hz	1500 R.P.M.	43 R.P.M.
	60 Hz	1800 R.P.M.	51 R.P.M.

MOTOR			50Hz			60Hz			TRANSCYKO MODEL	Dimension page	
KW	HP	SYMBOL	Output Torque kgf·m / in·lbs	Allowable Output Shaft Overhung load kgf / lbs	S.F.	Output Torque kgf·m / in·lbs	Allowable Output Shaft Overhung load kgf / lbs	S.F.		H	V
0.2	1/4	02	6.12/531	340/748	1.80	5.10/443	340/748	1.80	02-609-51	50	106
0.4	1/2	05	12.2/1059	550/1210	1.68	10.2/885	550/1210	1.65	05-610-51	51	107
0.75	1	1	23.0/1996	880/1936	2.21	19.1/1658	880/1936	2.49	1-611-51	52	108
	2	2	45.9/3984	880/1936	1.11	38.2/3316	880/1936	1.25	2-611-51	52	108
				1220/2684	1.67		1150/2530	1.68	2-613-51	54	110
	3	3	67.3/5842	1220/2684	1.14	66.1/4869	1150/2530	1.14	3-613-51	54	110
				1500/3300	1.35		1460/3212	1.34	3-614-51	55	111
				1847/4063.4	2.03		1802/3964.4	2.21	3-615-51	56	112
				2115/4653	2.43		2001/4402.2	2.53	3-616-51	57	113
	5	5	113/9808	2084/4584.8	1.46	94.4/8194	1967/4327.4	1.5	5-616-51	57	113
				2340/5148	2.25		2200/4840	2.86	5-617-51	58	114
	7.5	8	168/14582	1990/4378	1.04	140/12152	1880/4136	1.03	8-616-51	57	113
				2340/5148	1.52		2200/4840	1.51	8-617-51	58	114
				3150/6930	2.07		2985/6567	2.07	8-618-51	59	115
	10	10	230/19964	2340/5148	1.11	191/16579	2200/4840	1.11	10-617-51	58	114
				3150/6930	1.52		2985/6567	1.52	10-618-51	59	115
				4400/9680	2.39		4150/9130	2.40	10-619-51	60	116
	15	15	337/29252	3150/6930	1.04	280/24304	2985/6567	1.04	15-618-51	59	115
				4400/9680	1.63		4150/9130	1.64	15-619-51	60	116
15	20	20	459/39841	4400/9680	1.19	383/33244	4150/9130	1.20	20-619-51	60	116

Ratio	Frequency	Motor Input Speed	Reducer Output Speed
59	50 Hz	1500 R.P.M.	25 R.P.M.
	60 Hz	1800 R.P.M.	31 R.P.M.

MOTOR			50Hz			60Hz			TRANSCYKO MODEL	Dimension page	
KW	HP	SYMBOL	Output Torque kgf·m / in·lbs	Allowable Output Shaft Overhung load kgf / lbs	S.F.	Output Torque kgf·m / in·lbs	Allowable Output Shaft Overhung load kgf / lbs	S.F.		H	V
0.2	1/4	02	7.08/614	340/748	1.65	5.90/512	340/748	1.65	02-609-59	50	106
	1/2	05	14.2/1232	550/1210	1.50	11.8/1024	550/1210	1.52	05-610-59	51	107
				880/1936	3.42		880/1936	3.45	05-611-59	52	108
0.75	1	1	26.6/2309	880/1936	1.83	22.1/1918	880/1936	1.84	1-611-59	52	108
	2	2	53.1/4609	1295/2849	1.43	44.3/3845	1220/2684	1.44	2-613-59	54	110
				1500/3300	1.87		1500/3300	1.89	2-614-59	55	111
				1901/4182.2	1.27		1500/3300	1.29	3-614-59	55	111
	3	3	77.9/6762	1901/4182.2	1.68	64.9/5633	1901/4182.2	1.8	3-615-59	56	112
				2204/4848.8	1.97		2204/4848.8	1.97	3-616-59	57	113

\*Please select models in the shaded column when a load factor of 1.0 is required as shown on page 8.



MOTOR			50Hz			60Hz			TRANSCYKO MODEL	Dimension page	
KW	HP	SYMBOL	Output Torque kgf·m / in·lbs	Allowable Output Shaft Overhung load kgf / lbs	S.F.	Output Torque kgf·m / in·lbs	Allowable Output Shaft Overhung load kgf / lbs	S.F.		H	V
2.2	3	3	77.9/6762	2000/4400	2.25	64.9/5633	1985/4367	2.23	3-616-59	57	113
3.7	5	5	131/11371	2184/4804.8	1.16	109/9461	2184/4804.8	1.16	5-616-59	57	113
				2490/5478	1.97		2340/5148	1.95	5-617-59	58	114
5.5	7.5	8	195/16926	2490/5478	1.32	162/14062	2340/5148	1.31	8-617-59	58	114
				3330/7326	1.79		3140/6908	1.77	8-618-59	59	115
7.5	10	10	266/23089	3300/7326	1.31	221/190183	3140/6908	1.30	10-618-59	59	115
				4660/10252	2.07		4400/9680	2.07	10-619-59	60	116
11	15	15	389/33765	4660/10252	1.41	325/28210	4400/9680	1.41	15-619-59	60	116
				5700/12540	1.74		5410/11902	1.74	15-620-59	61	117
15	20	20	531/46091	4660/10252	1.03	443/38452	4400/9680	1.03	20-619-59	60	116
				5700/12540	1.27		5410/11902	1.28	20-620-59	61	117
				7265/15983	1.85		4400/9680	1.85	20-621-59	62	118
18.5	25	25	655/56854	5700/12540	1.03	546/47393	5410/11902	1.04	25-620-59	61	117
				7265/15983	1.50		6890/15158	1.50	25-621-59	62	118
				7640/16808	1.80		7250/15950	1.80	25-622-59	63	119
22	30	30	779/67617	7265/15983	1.26	649/56333	6890/15158	1.26	30-621-59	62	118
				7640/16808	1.52		7250/15950	1.51	30-622-59	63	119
30	40	40	1062/92182	7640/16808	1.11	885/76818	7250/15950	1.11	40-622-59	63	119

Ratio	Frequency	Motor Input Speed	Reducer Output Speed
71	50 Hz	1500 R.P.M.	21 R.P.M.
	60 Hz	1800 R.P.M.	25 R.P.M.

MOTOR			50Hz			60Hz			TRANSCYKO MODEL	Dimension page	
KW	HP	SYMBOL	Output Torque kgf·m / in·lbs	Allowable Output Shaft Overhung load kgf / lbs	S.F.	Output Torque kgf·m / in·lbs	Allowable Output Shaft Overhung load kgf / lbs	S.F.		H	V
0.2	1/4	02	8.52/740	340/748	1.30	7.10/616	340/748	1.30	02-609-71	50	106
				550/1210	2.45		550/1210	2.45	02-610-71	51	107
0.4	1/2	05	17.0/1476	550/1210	1.22	14.2/1232	550/1210	1.22	05-610-71	51	107
				880/1936	2.45		880/1936	2.45	05-611-71	52	108
0.75	1	1	32.0/2778	880/1936	1.31	26.6/2309	880/1936	1.31	1-611-71	52	108
				1000/2200	1.36		1000/2200	1.35	1-612-71	53	109
				1350/2970	2.40		1295/2849	2.43	1-613-71	54	110
1.5	2	2	63.9/5546	1350/2970	1.20	53.2/4618	1295/2849	1.21	2-613-71	54	110
				1500/3300	1.41		1500/3300	1.40	2-614-71	55	111
				1881/4138.2	1.94		1881/4138.2	1.96	2-615-71	56	112
				2204/4848.8	2.25		2204/4848.8	2.25	2-616-71	57	113
2.2	3	3	93.7/8133	1901/4182.2	1.34	78.1/6779	1901/4182.2	1.45	3-615-71	56	112
				2184/4804.8	1.54		2184/4804.8	1.62	3-616-71	57	113
3.7	5	5	158/13714	2000/4000	1.10	131/11371	2000/4400	1.11	5-616-71	57	113
				2680/5896	1.62		2490/5478	1.62	5-617-71	58	114
5.5	7.5	8	234/20422	2680/5896	1.09	195/16926	2460/5478	1.09	8-617-71	58	114
				3590/7898	1.34		3330/7326	1.33	8-618-71	59	115
				5020/11044	2.44		4660/10252	2.44	8-619-71	60	116
7.5	10	10	320/27776	3590/7898	1.00	266/23089	3330/7326	1.00	10-618-71	59	115
				5020/11044	1.79		4660/10252	1.79	10-619-71	60	116
11	15	15	469/40709	5020/11044	1.22	391/33939	4660/10252	1.22	15-619-71	60	116

Ratio	Frequency	Motor Input Speed	Reducer Output Speed
87	50 Hz	1500 R.P.M.	17 R.P.M.
	60 Hz	1800 R.P.M.	21 R.P.M.

MOTOR			50Hz			60Hz			TRANSCYKO MODEL	Dimension page	
KW	HP	SYMBOL	Output Torque kgf·m / in·lbs	Allowable Output Shaft Overhung load kgf / lbs	S.F.	Output Torque kgf·m / in·lbs	Allowable Output Shaft Overhung load kgf / lbs	S.F.		H	V
0.2	1/4	02	10.4/903	340/748	1.25	8.70/755	340/748	1.20	02-609-87	50	106
				550/1210	2.45		550/1210	2.45	02-610-87	51	107

\*Please select models in the shaded column when a load factor of 1.0 is required as shown on page 8.



Ratio	Frequency	Motor Input Speed	Reducer Output Speed
87	50 Hz	1500 R.P.M.	17 R.P.M.
	60 Hz	1800 R.P.M.	21 R.P.M.

MOTOR			50Hz			60Hz			TRANSCYKO MODEL	Dimension page	
KW	HP	SYMBOL	Output Torque kgf·m / in·lbs	Allowable Output Shaft Overhung load kgf / lbs	S.F.	Output Torque kgf·m / in·lbs	Allowable Output Shaft Overhung load kgf / lbs	S.F.		H	V
0.4	1/2	05	20.9/1814	550/1210	1.22	17.4/1510	550/1210	1.22	05-610-87	51	107
				880/1936	2.33		880/1936	2.33	05-611-87	52	108
0.75	1	1	39.2/3402	880/1936	1.24	32.6/2830	880/1936	1.24	1-611-87	52	108
				1364/3001	1.95		1360/2992	1.96	1-613-87	54	110
1.5	2	2	78.3/6796	1500/3300	1.30	65.2/5659	1500/3300	1.31	2-614-87	55	111
				1881/4138.2	1.74		1881/4138.2	1.74	2-615-87	56	112
				2184/4804.8	2.09		2184/4804.8	2.09	2-616-87	57	113
2.2	3	3	115/9982	2050/4510	1.52	95.7/8342	2000/4400	1.52	3-616-87	57	113
				2900/6380	2.20		2660/5852	2.20	3-617-87	58	114
3.7	5	5	193/16752	2900/6380	1.31	161/13975	2660/5852	1.31	5-617-87	58	114
				3760/8272	2.03		3540/7788	2.03	5-618-87	59	115
5.5	7.5	8	287/24912	3760/8272	1.34	239/20745	3540/7788	1.34	8-618-87	59	115
				5260/11572	2.13		4950/10890	2.13	8-619-87	60	116
7.5	10	10	392/34026	5260/11572	1.56	326/28297	4950/10890	1.56	10-619-87	60	116
				6600/14520	1.83		6030/13266	1.81	10-620-87	61	117
11	15	15	574/49823	5260/11572	1.06	478/41490	4950/10890	1.06	15-619-87	60	116
				6600/14520	1.24		6030/13266	1.24	15-620-87	61	117
				8410/18502	1.65		7680/16896	1.66	15-621-87	62	118
				8840/19448	1.99		8090/17798	1.99	15-622-87	63	119
15	20	20	783/67964	8410/18502	1.22	652/56594	7680/16896	1.21	20-621-87	62	118
				8840/19448	1.46		8090/17798	1.46	20-622-87	63	119
18.5	25	25	966/83849	8840/19448	1.18	805/69874	8090/17798	1.18	25-622-87	63	119

Ratio	Frequency	Motor Input Speed	Reducer Output Speed
104 (13x8)	50 Hz	1500 R.P.M.	14 R.P.M.
	60 Hz	1800 R.P.M.	21 R.P.M.

MOTOR			50Hz			60Hz			TRANSCYKO MODEL	Dimension page	
KW	HP	SYMBOL	Output Torque kgf·m / in·lbs	Allowable Output Shaft Overhung load kgf / lbs	S.F.	Output Torque kgf·m / in·lbs	Allowable Output Shaft Overhung load kgf / lbs	S.F.		H	V
0.2	1/4	02	10.1/877	340/748	<1.0	9.48/823	340/748	1.05	02-609/08-104	70	126
			11.4/990	550/1210	1.80	9.48/823	550/1210	1.91	02-610/08-104	71	127
0.4	1/2	05	20.5/1779	550/1210	<1.0	18.7/1625	550/1210	1.06	05-610/08-104	71	127
			22.7/1970	880/1936	1.00	19.0/1649	880/1936	1.02	05-611/08-104	72	128
			22.7/1970	880/1936	2.10	19.0/1649	880/1936	2.42	05-611/09-104	73	129
0.75	1	1	42.6/3724	880/1936	1.12	35.5/3081	880/1936	1.29	1-611/09-104	73	129
			42.6/3724	1365/3003	1.80	35.5/3081	1365/3003	2.16	1-613/10-104	76	132
1.5	2	2	77.0/6684	1365/3003	<1.0	71.1/6171	1365/3003	1.08	2-613/10-104	76	132
			85.3/7404	2050/4510	1.61	71.1/6171	2050/4510	2.25	2-616/10-104	81	137
2.2	3	3	77.0/6684	1365/3003	<1.0	77.0/6684	1365/3003	<1.0	3-613/10-104	76	132
			103/8940	1500/3300	<1.0	102/8854	1500/3300	<1.0	3-614/10-104	79	135
			125/10850	2050/4510	1.46	104/9027	2050/4510	1.74	3-616/11-104	82	138
3.7	5	5	183/15884	2050/4510	<1.0	175/15190	2050/4510	1.04	5-616/11-104	82	138
			210/18228	2900/6380	1.32	175/15190	2900/6380	1.38	5-617/11-104	85	141
5.5	7.5	8	278/24130	2900/6380	<1.0	241/20919	2900/6380	<1.0	8-617/11-104	85	141
			313/27168	3800/8360	1.28	260/22568	3800/8360	1.54	8-618/13-104	87	143
7.5	10	10	400/34720	3800/8360	<1.0	355/30814	3800/8360	1.13	10-618/13-104	87	143
			426/36977	5300/11660	1.33	355/30814	5300/11660	1.41	10-619/13-104	89	145

\*Please select models in the shaded column when a load factor of 1.0 is required as shown on page 8.

\*When S.F. marked as <1, overload may occur if the motor is loaded to its full KW(HP) capacity, in which case it must be used within the values stipulated in the output torque column.

Ratio	Frequency	Motor Input Speed	Reducer Output Speed
119	50 Hz	1500 R.P.M.	13 R.P.M.
	60 Hz	1800 R.P.M.	15 R.P.M.

MOTOR			50Hz			60Hz			TRANSCYKO MODEL	Dimension page	
KW	HP	SYMBOL	Output Torque kgf·m / in·lbs	Allowable Output Shaft Overhung load kgf / lbs	S.F.	Output Torque kgf·m / in·lbs	Allowable Output Shaft Overhung load kgf / lbs	S.F.		H	V
0.2	1/4	02	14.6/1267	550/1210	1.25	12.2/1059	550/1210	1.20	02-610-119	51	107



Ratio	Frequency	Motor Input Speed	Reducer Output Speed
121 (11x11)	50 Hz	1500 R.P.M.	12 R.P.M.
	60 Hz	1800 R.P.M.	15 R.P.M.

MOTOR			50Hz			60Hz			TRANSCYKO MODEL	Dimension page	
KW	HP	SYMBOL	Output Torque kgf·m / in·lbs	Allowable Output Shaft Overhung load kgf / lbs	S.F.	Output Torque kgf·m / in·lbs	Allowable Output Shaft Overhung load kgf / lbs	S.F.		H	V
0.2	1/4	02	10.1/877	340/748	<1.0	10.2/885	340/748	<1.0	02-609/08-121	70	126
			13.2/1146	550/1210	1.55	11.0/955	550/1210	1.90	02-610/08-121	71	127
0.4	1/2	05	20.5/1779	550/1210	<1.0	21.1/1831	550/1210	<1.0	05-610/08-121	71	127
			26.4/2292	880/1936	1.00	22.0/1910	880/1936	1.00	05-611/08-121	72	128
			26.4/2292	880/1936	1.90	22.0/1910	880/1936	2.12	05-611/09-121	73	129
0.75	1	1	49.6/4305	880/1936	1.01	41.3/3585	880/1936	1.13	1-611/09-121	73	129
			49.6/4305	1370/3014	1.41	41.3/3585	1365/3003	1.63	1-613/09-121	75	131
1.5	2	2	77.0/6684	1370/3014	<1.0	77.0/6684	1365/3003	<1.0	2-613/10-121	76	132
			96.0/8333	1500/3300	<1.0	82.7/7178	1500/3300	1.16	2-614/10-121	79	135
			99.2/8610	2100/4620	1.71	82.7/7178	2050/4510	2.05	2-616/10-121	81	137
2.2	3	3	96.0/8333	1500/3300	<1.0	96.2/8350	1500/3300	<1.0	3-614/10-121	79	135
			146/12673	2100/4620	1.26	121/10503	2050/4510	1.50	3-616/11-121	82	138
			146/12673	2950/6490	1.75	121/10503	2900/6380	2.11	3-617/11-121	85	141
3.7	5	5	183/15884	2100/4620	<1.0	182/15798	2050/4510	<1.0	5-616/11-121	82	138
			245/21266	2950/6490	1.04	204/17707	2900/6380	1.25	5-617/11-121	85	141
			245/21266	3800/8360	1.37	204/17707	3800/8360	1.65	5-618/13-121	87	143
5.5	7.5	7.5	255/22134	2950/6490	<1.0	256/22221	2900/6380	<1.0	8-617/11-121	85	141
			335/29078	3950/8690	<1.0	303/26300	3800/8360	1.11	8-618/13-121	87	143
			364/31595	5300/11660	1.56	303/26300	5300/11660	1.75	8-619/13-121	89	145
7.5	10	10	496/43053	5300/11660	1.15	413/35848	5300/11660	1.28	10-619/13-121	89	145
			496/43053	7100/15620	1.16	413/35848	6650/14630	1.32	10-620/13-121	91	147
			496/43053	8850/19470	1.48	413/35848	8470/18634	1.72	10-621/16-121	93	149
11	15	15	728/63190	8850/19470	1.01	606/52601	8470/18634	1.17	15-621/16-121	93	149
			728/63190	10450/22990	1.32	606/52601	8910/19600	1.47	15-622/17-121	95	151
15	20	20	960/83328	10450/22990	<1.0	827/71784	8910/19600	1.10	20-622/17-121	95	151
			992/86106	12500/27500	1.15	827/71784	11100/24420	1.30	20-623/16-121	96	152
			992/86106	14100/31020	1.43	827/71784	12400/27280	1.72	20-624/18-121	99	155
18.5	25	25	960/83328	10450/22990	<1.0	910/78988	8930/19646	<1.0	25-622/17-121	95	151
			1120/97216	12500/27500	<1.0	1020/88536	11150/24530	1.09	25-623/18-121	97	153
			1224/106243	14100/31020	1.15	1020/88536	12450/27390	1.38	25-624/18-121	99	155
			1224/106243	17105/37631	1.47	1020/88536	15100/33220	1.48	25-625/19-121	101	157
22	30	30	1120/97216	12500/27500	<1.0	1110/96459	11150/24530	<1.0	30-623/18-121	97	153
			1410/122388	14100/31020	<1.0	1213/105288	12450/27390	1.16	30-624/18-121	99	155
			1455/126294	17105/37631	1.24	1213/105288	15100/33220	1.50	30-625/19-121	101	157
30	40	40	1800/156240	17105/37631	<1.0	1653/143480	15100/33220	1.10	40-625/19-121	101	157
			1984/172211	20900/45980	1.21	1653/143480	18450/40599	1.43	40-626/19-121	102	158
37	50	50	2400/208320	20900/45980	<1.0	2040/177072	18450/40590	1.16	50-626/19-121	102	158

Ratio	Frequency	Motor Input Speed	Reducer Output Speed
143 (13x11)	50 Hz	1500 R.P.M.	10 R.P.M.
	60 Hz	1800 R.P.M.	13 R.P.M.

MOTOR			50Hz			60Hz			TRANSCYKO MODEL	Dimension page	
KW	HP	SYMBOL	Output Torque kgf·m / in·lbs	Allowable Output Shaft Overhung load kgf / lbs	S.F.	Output Torque kgf·m / in·lbs	Allowable Output Shaft Overhung load kgf / lbs	S.F.		H	V
0.2	1/4	02	10.9/946	340/748	<1.0	11.2/972	340/748	<1.0	02-609/08-143	70	126
			15.6/1354	550/1210	1.30	13.0/1128	550/1210	1.70	02-610/08-143	71	127
0.4	1/2	05	31.3/2717	880/1936	1.00	26.0/2257	880/1936	1.00	05-611/08-143	72	128
			31.3/2717	880/1936	1.62	26.0/2257	880/1936	1.93	05-611/09-143	73	129
0.75	1	1	51.0/4427	880/1936	<1.0	48.8/4236	880/1936	1.03	1-611/09-143	73	129
			58.6/5086	1365/3003	1.31	48.8/4236	1365/3003	1.57	1-613/09-143	75	131
1.5	2	2	77.0/6684	1365/3003	<1.0	77.0/6684	1365/3003	<1.0	2-613/10-143	76	132
			103/8940	1500/3300	<1.0	97.7/8480	1500/3300	1.04	2-614/10-143	79	135
			117/10156	2050/4510	1.56	97.7/8480	2050/4510	1.84	2-616/10-143	81	137

\*When S.F. marked as < 1, overload may occur if the motor is loaded to its full KW (HP) capacity, in which case it must be used within the values stipulated in the output torque column.



Ratio	Frequency	Motor Input Speed	Reducer Output Speed
143 (13x11)	50 Hz	1500 R.P.M.	10 R.P.M.
	60 Hz	1800 R.P.M.	13 R.P.M.

MOTOR			50Hz			60Hz			TRANSCYKO MODEL	Dimension page	
KW	HP	SYMBOL	Output Torque kgf·m / in·lbs	Allowable Output Shaft Overhung load kgf / lbs	S.F.	Output Torque kgf·m / in·lbs	Allowable Output Shaft Overhung load kgf / lbs	S.F.		H	V
2.2	3	3	172/14930	2050/4510	1.06	143/12412	2050/4510	1.25	3-616/10-143	81	137
			172/14930	2050/4510	1.06	143/12412	2050/4510	1.27	3-616/11-143	82	138
			172/14930	2900/6380	1.62	143/12412	2900/6380	1.92	3-617/11-143	85	141
3.7	5	5	183/15884	2050/4510	<1.0	182/15798	2050/4510	<1.0	5-616/11-143	82	138
			278/24130	2900/6380	<1.0	241/20919	2900/6380	1.14	5-617/11-143	85	141
			289/25085	3900/8580	1.39	241/20919	3800/8360	1.66	5-618/13-143	87	143
5.5	7.5	8	401/34807	3900/8580	<1.0	358/31074	3800/8360	1.12	8-618/13-143	87	143
			430/37324	5300/11660	1.42	358/31074	5300/11660	1.59	8-619/13-143	89	145
7.5	10	10	586/50865	5300/11660	1.04	488/42358	5300/11660	1.17	10-619/13-143	89	145

Ratio	Frequency	Motor Input Speed	Reducer Output Speed
165 (15x11)	50 Hz	1500 R.P.M.	9.1 R.P.M.
	60 Hz	1800 R.P.M.	11 R.P.M.

MOTOR			50Hz			60Hz			TRANSCYKO MODEL	Dimension page	
KW	HP	SYMBOL	Output Torque kgf·m / in·lbs	Allowable Output Shaft Overhung load kgf / lbs	S.F.	Output Torque kgf·m / in·lbs	Allowable Output Shaft Overhung load kgf / lbs	S.F.		H	V
0.2	1/4	02	13.0/1128	340/748	<1.0	12.7/1104	340/748	<1.0	02-609/08-165	70	126
			18.0/1562	550/1210	1.45	15.0/1302	550/1210	1.70	02-610/08-165	71	127
0.4	1/2	05	26.0/2257	550/1210	<1.0	26.0/2257	550/1210	<1.0	05-610/08-165	71	127
			36.1/3133	880/1936	1.00	30.1/2613	880/1936	1.00	05-611/08-165	72	128
			36.1/3133	880/1936	1.40	30.1/2613	880/1936	1.70	05-611/09-165	73	129
0.75	1	1	51.0/4427	880/1936	<1.0	51.0/4427	880/1936	<1.0	1-611/09-165	73	129
			67.6/5868	1365/3003	1.13	56.4/4896	1365/3003	1.36	1-613/09-165	75	131
			67.6/5868	1500/3300	1.36	56.4/4896	1500/3300	1.61	1-614/09-165	78	134
1.5	2	2	77.0/6684	1365/3003	<1.0	77.0/6684	1365/3003	<1.0	2-613/10-165	76	132
			103/8940	1500/3300	<1.0	103/8940	1500/3300	<1.0	2-614/10-165	79	135
			135/11718	2050/4510	1.35	113/9808	2050/4510	1.61	2-616/10-165	81	137
2.2	3	3	183/15903	2050/4510	<1.0	165/14322	2050/4510	1.10	3-616/10-165	81	137
			198/17186	2900/6380	1.16	165/14322	2900/6380	1.39	3-617/10-165	84	140
			198/17186	2900/6380	1.40	165/14322	2900/6380	1.59	3-617/11-165	85	141
3.7	5	5	278/24130	2900/6380	<1.0	263/22828	2900/6380	<1.0	5-617/11-165	85	141
			334/28991	3900/8580	1.23	278/24130	3850/8470	1.47	5-618/13-165	87	143
			334/28991	5300/11660	1.83	278/24130	5300/11660	2.05	5-619/13-165	89	145
5.5	7.5	8	410/35588	3900/8580	<1.0	410/35588	3850/8470	<1.0	8-618/13-165	87	143
			496/43053	5300/11660	1.23	413/35848	5300/11660	1.38	8-619/13-165	89	145
7.5	10	10	610/52948	5300/11660	<1.0	564/48955	5300/11660	1.01	10-619/13-165	89	145
			677/58764	7050/15510	1.03	564/48955	7050/15510	1.19	10-620/13-165	91	147
			677/58764	8810/19382	1.26	564/48955	8780/19316	1.32	10-621/13-165	92	148
11	15	15	855/74214	8810/19382	<1.0	827/71784	8780/19316	1.03	15-621/16-165	93	149
			992/86106	10400/22880	1.11	827/71784	9950/21890	1.33	15-622/17-165	95	151
			992/86106	12900/28380	1.41	827/71784	12200/26840	1.64	15-623/16-165	96	152
15	20	20	1100/95480	10400/22880	<1.0	1100/95480	9950/21890	<1.0	20-622/17-165	95	151
			1353/117440	12900/28380	1.03	1127/97824	12200/26840	1.21	20-623/16-165	96	152
			1353/117440	14400/31680	1.24	1127/97824	13600/29920	1.21	20-624/16-165	98	154
18.5	25	25	1400/121520	12900/28380	<1.0	1360/18048	12200/26840	<1.0	25-623/18-165	97	153
			1669/144869	14400/31680	1.09	1390/120652	13600/29920	1.30	25-624/18-165	99	155
			1669/144869	17600/38720	1.38	1390/120652	16600/36520	1.73	25-625/19-165	101	157
22	30	30	1400/121520	12900/28380	<1.0	1360/118048	12200/26840	<1.0	30-623/18-165	97	153
			1810/157108	14400/31680	<1.0	1654/143567	13600/29920	1.10	30-624/18-165	99	155
			1984/172211	17600/38720	1.16	1654/143567	16600/36520	1.45	30-625/19-165	101	157
			1984/172211	21400/47080	1.54	1654/143567	20350/44770	1.77	30-626/19-165	102	158
30	40	40	2300/199640	17600/38720	<1.0	2255/195734	16600/36520	1.07	40-625/19-165	101	157
			2706/234881	21400/47080	1.13	2255/195734	20350/44770	1.30	40-626/19-165	102	158
37	50	50	3050/264740	21400/47080	<1.0	2781/241391	20350/44770	1.05	50-626/19-165	102	158

\*When S.F. marked as <1, overload may occur if the motor is loaded to its full KW (HP) capacity, in which case it must be used within the values stipulated in the output torque column.



Ratio	Frequency	Motor Input Speed	Reducer Output Speed
195 (15x13)	50 Hz	1500 R.P.M.	7.7 R.P.M.
	60 Hz	1800 R.P.M.	9.2 R.P.M.

MOTOR			50Hz			60Hz			TRANSCYKO MODEL	Dimension page	
KW	HP	SYMBOL	Output Torque kgf·m / in·lbs	Allowable Output Shaft Overhung load kgf / lbs	S.F.	Output Torque kgf·m / in·lbs	Allowable Output Shaft Overhung load kgf / lbs	S.F.		H	V
0.2	1/4	02	21.3/1849	550/1210	1.20	17.8/1545	550/1210	1.45	02-610/08-195	71	127
			21.3/1849	880/1936	2.00	17.8/1545	880/1936	2.00	02-611/08-195	72	128
0.4	1/2	05	26.0/2257	550/1210	<1.0	26.0/2257	550/1210	<1.0	05-610/08-195	71	127
			42.6/3698	880/1936	1.00	35.5/3081	880/1936	1.00	05-611/08-195	72	128
			42.6/3698	880/1936	1.20	35.5/3081	880/1936	1.42	05-611/09-195	73	129
			42.6/3698	1365/3003	1.72	35.5/3081	1365/3003	2.18	05-613/09-195	75	131
0.75	1	1	51.0/4427	880/1936	<1.0	51.0/4427	880/1936	<1.0	1-611/09-195	73	129
			77.0/6684	1365/3003	<1.0	66.6/5781	1365/3003	1.16	1-613/09-195	75	131
			80.0/6944	1500/3300	1.29	66.6/5781	1500/3300	1.55	1-614/10-195	79	135
1.5	2	2	103/8940	1500/3300	<1.0	103/8940	1500/3300	<1.0	2-614/10-195	79	135
			160/13888	2050/4510	1.15	133/11544	2050/4510	1.37	2-616/10-195	81	137
			160/13888	2900/6380	1.61	133/11544	2900/6380	1.79	2-617/10-195	84	140
2.2	3	3	183/15884	2050/4510	<1.0	183/15884	2050/4510	<1.0	3-616/10-195	81	137
			234/20311	2900/6380	1.10	195/16926	2900/6380	1.22	3-617/10-195	84	140
			234/20311	2900/6380	1.19	195/16926	2900/6380	1.41	3-617/11-195	85	141
			234/20311	4000/8800	1.75	195/16926	3950/8690	2.10	3-618/13-195	87	143
3.7	5	5	278/24130	2900/6380	<1.0	278/24130	2900/6380	<1.0	5-617/11-195	85	141
			394/34199	4000/8800	1.04	329/28557	3950/8690	1.25	5-618/13-195	87	143
			394/34199	5400/11880	1.29	329/28557	5300/11660	1.52	5-619/11-195	88	144
5.5	7.5	8	410/35588	4000/8800	<1.0	410/35588	3800/8360	<1.0	8-618/13-195	87	143
			586/50865	5400/11880	1.11	488/42358	5300/11660	1.25	8-619/13-195	89	145
			586/50865	8000/17600	1.18	488/42358	7050/15510	1.42	8-620/13-195	91	147
			586/50865	8800/19360	1.46	488/42358	8800/19360	1.72	8-621/13-195	92	148
7.5	10	10	650/56420	5400/11880	<1.0	610/52948	5300/11660	<1.0	10-619/13-195	89	145
			695/60326	8000/17600	<1.0	666/57809	7050/15510	1.04	10-620/13-195	91	147
			800/69440	8800/19360	1.07	666/57809	8800/19360	1.26	10-621/13-195	92	148
			800/69440	10900/23980	1.26	666/57809	10300/22660	1.30	10-622/13-195	94	150
11	15	15	855/74214	8800/19360	<1.0	850/37780	8800/19360	<1.0	15-621/16-195	93	149
			1100/95480	10900/23980	<1.0	977/84804	10300/22660	1.14	15-622/17-195	95	151
			1172/101730	13800/30360	1.19	977/84804	12800/28160	1.44	15-623/16-195	96	152
			1172/101730	15300/30360	1.54	977/84804	14300/31460	1.58	15-624/16-195	98	154
15	20	20	1100/95480	10900/23980	<1.0	1120/97216	10300/22660	<1.0	20-622/17-195	95	151
			1400/121520	13800/30360	<1.0	1332/115618	12800/28160	1.06	20-623/16-195	96	152
			1599/138793	15300/33660	1.13	1332/115618	14300/31460	1.16	20-624/16-195	98	154
			1599/138793	19100/42020	1.44	1332/115618	17500/38500	1.76	20-625/17-195	100	156
18.5	25	25	1810/157108	15300/33660	<1.0	1643/142612	14300/31460	1.16	25-624/18-195	99	155
			1972/171170	19100/42020	1.17	1643/142612	17500/38500	1.32	25-625/17-195	100	156
			1972/171170	23200/51040	1.55	1643/142612	21300/46860	1.85	25-626/19-195	102	158
22	30	30	1810/157108	15300/33660	<1.0	1810/157108	14300/31460	<1.0	30-624/18-195	99	155
			2300/199640	19100/42020	<1.0	1954/169607	17500/38500	1.20	30-625/17-195	100	156
			2345/203546	23200/51040	1.30	1954/169607	21300/46800	1.58	30-626/19-195	102	158
30	40	40	3050/264740	23200/51040	<1.0	2665/231322	21300/46860	1.16	40-626/19-195	102	158

Ratio	Frequency	Motor Input Speed	Reducer Output Speed
231 (21x11)	50 Hz	1500 R.P.M.	6.5 R.P.M.
	60 Hz	1800 R.P.M.	7.8 R.P.M.

MOTOR			50Hz			60Hz			TRANSCYKO MODEL	Dimension page	
KW	HP	SYMBOL	Output Torque kgf·m / in·lbs	Allowable Output Shaft Overhung load kgf / lbs	S.F.	Output Torque kgf·m / in·lbs	Allowable Output Shaft Overhung load kgf / lbs	S.F.		H	V
0.2	1/4	02	25.2/2189	550/1210	1.01	21.5/1868	550/1210	1.20	02-610/08-231	71	127
			26.0/2259	880/1936	1.96	21.6/1877	880/1936	1.89	02-611/08-231	72	128
0.4	1/2	05	52.1/4527	880/1936	1.01	43.1/3745	880/1936	1.02	05-611/08-231	72	128
			52.5/4562	1365/3003	1.51	43.3/3763	1365/3003	1.81	05-613/09-231	75	131

\*When S.F. marked as <1, overload may occur if the motor is loaded to its full KW (HP) capacity, in which case it must be used within the values stipulated in the output torque column.



Ratio	Frequency	Motor Input Speed	Reducer Output Speed
231 (21x11)	50 Hz	1500 R.P.M.	6.5 R.P.M.
	60 Hz	1800 R.P.M.	7.8 R.P.M.

MOTOR			50Hz			60Hz			TRANSCYKO MODEL	Dimension page	
KW	HP	SYMBOL	Output Torque kgf·m / in·lbs	Allowable Output Shaft Overhung load kgf / lbs	S.F.	Output Torque kgf·m / in·lbs	Allowable Output Shaft Overhung load kgf / lbs	S.F.		H	V
0.75	1	1	51.0/4427	880/1936	<1.0	51.0/4427	880/1936	<1.0	1-611/09-231	73	129
			77.0/6684	1365/3003	<1.0	77.0/6684	1365/3003	<1.0	1-613/09-231	75	131
			94.7/8221	1500/3300	1.09	78.9/6848	1500/3300	1.29	1-614/09-231	78	134
			94.7/8221	2050/4510	1.53	78.9/6848	2050/4510	1.77	1-616/09-231	80	136
1.5	2	2	183/15884	2050/4510	<1.0	158/13714	2050/4510	1.16	2-616/10-231	81	137
			189/16405	2900/6380	1.47	158/13714	2900/6380	1.76	2-617/10-231	84	140
2.2	3	3	278/24130	2900/6380	1.00	232/20138	2900/6380	1.20	3-617/10-231	84	140
			278/24130	4000/8800	1.13	232/20138	4000/8800	1.27	3-618/10-231	86	142
			278/24130	4000/8800	1.48	232/20138	4000/8800	1.77	3-618/13-231	87	143
3.7	5	5	278/24130	2900/6380	<1.0	278/24130	2900/6380	<1.0	5-617/11-231	85	141
			410/35588	4000/8800	<1.0	389/33765	4000/8800	1.05	5-618/13-231	87	143
			467/41104	5400/11880	1.20	389/33765	5400/11880	1.35	5-619/11-231	88	144
			467/41104	5400/11880	1.56	389/33765	5400/11880	1.84	5-619/13-231	89	145
5.5	7.5	8	694/60239	5400/11880	1.05	579/50257	5400/11880	1.23	8-619/13-231	89	145
			694/60239	8000/17600	1.05	579/50257	8000/17600	1.26	8-620/13-231	91	147
			694/60239	8800/19360	1.39	579/50257	8800/19360	1.66	8-621/13-231	92	148
7.5	10	10	730/83364	7000/17600	<1.0	735/63364	8000/17600	<1.0	10-620/13-231	91	147
			947/82200	8800/19360	1.02	790/69259	8800/19360	1.22	10-621/13-231	92	148
			947/82200	11900/26180	1.32	798/69349	10900/23980	1.32	10-622/13-231	94	150
11	15	15	965/83762	8800/19360	<1.0	968/84022	8800/19360	<1.0	15-621/16-231	93	149
			1275/110670	11900/26180	<1.0	1158/100514	10900/23980	1.08	15-622/17-231	95	151
			1389/120565	14000/30800	1.14	1158/100514	13800/30360	1.31	15-623/16-231	96	152
			1389/120565	16000/35200	1.45	1158/100514	15300/33660	1.65	15-624/16-231	98	154
15	20	20	1590/138012	14000/30800	<1.0	1520/131936	13800/30360	<1.0	20-623/16-231	96	152
			1894/164399	16000/35200	1.07	1578/136970	15300/33660	1.21	20-624/16-231	98	154
			1894/164399	19400/42680	1.40	1578/136970	19100/42020	1.68	20-625/17-231	100	156
18.5	25	25	2050/177940	16000/35200	<1.0	1947/169000	15300/33660	1.03	25-624/18-231	99	155
			2336/202765	19400/42680	1.14	1947/169000	19100/42020	1.36	25-625/17-231	100	156
			2336/202765	23700/52140	1.48	1947/169000	23200/51040	1.70	25-626/19-231	102	158
22	30	30	2050/177940	16000/35200	<1.0	2000/173600	15300/33660	<1.0	30-624/18-231	99	155
			2050/230020	19400/42680	<1.0	2315/200942	19100/42020	1.14	30-625/17-231	100	156
			2778/241130	23700/52140	1.24	2315/200942	23200/51040	1.43	30-626/19-231	102	158
30	40	40	2650/230020	19400/42680	<1.0	2650/230020	19100/42020	<1.0	40-625/19-231	101	157
			3460/300328	23700/52140	<1.0	3157/274028	23200/51040	1.05	40-626/19-231	102	158
37	50	50	3460/300328	23700/52140	<1.0	3304/286787	23200/51040	<1.0	50-626/19-231	102	158

Ratio	Frequency	Motor Input Speed	Reducer Output Speed
273 (21x13)	50 Hz	1500 R.P.M.	5.5 R.P.M.
	60 Hz	1800 R.P.M.	6.6 R.P.M.

MOTOR			50Hz			60Hz			TRANSCYKO MODEL	Dimension page	
KW	HP	SYMBOL	Output Torque kgf·m / in·lbs	Allowable Output Shaft Overhung load kgf / lbs	S.F.	Output Torque kgf·m / in·lbs	Allowable Output Shaft Overhung load kgf / lbs	S.F.		H	V
0.2	1/4	02	26.0/2257	550/1210	<1.0	24.9/2161	550/1210	1.05	02-610/08-273	71	127
			29.8/2578	880/1936	1.70	24.9/2161	880/1936	2.00	02-611/08-273	72	128
0.4	1/2	05	51.0/4427	880/1936	<1.0	49.7/4314	880/1936	1.00	05-611/08-273	72	128
			60.0/5208	1365/3003	1.30	49.7/4314	1365/3003	1.55	05-613/09-273	75	131
0.75	1	1	77.0/6684	1365/3003	<1.0	77.0/6684	1365/3003	<1.0	1-613/09-273	75	131
			103/8940	1500/3300	<1.0	93.3/8098	1500/3300	1.09	1-614/10-273	79	135
			112/9722	2050/4510	1.64	93.3/8098	2050/4510	1.96	1-616/10-273	81	137
1.5	2	2	183/15884	2050/4510	<1.0	183/15884	2050/4510	<1.0	2-616/10-273	81	137
			224/19443	2900/6380	1.24	186/16145	2900/6380	1.49	2-617/10-273	84	140
			224/19443	4000/8800	1.80	186/16145	4000/8800	1.78	2-618/10-273	86	142

\*When S.F. marked as <1, overload may occur if the motor is loaded to its full KW (HP) capacity, in which case it must be used within the values stipulated in the output torque column.



Ratio	Frequency	Motor Input Speed	Reducer Output Speed
273 (21x13)	50 Hz	1500 R.P.M.	5.5 R.P.M.
	60 Hz	1800 R.P.M.	6.6 R.P.M.

MOTOR			50Hz			60Hz			TRANSCYKO MODEL	Dimension page	
KW	HP	SYMBOL	Output Torque kgf·m / in·lbs	Allowable Output Shaft Overhung load kgf / lbs	S.F.	Output Torque kgf·m / in·lbs	Allowable Output Shaft Overhung load kgf / lbs	S.F.		H	V
2.2	3	3	278/24130	2900/6380	<1.0	274/23783	2900/6380	1.02	3-617/10-273	84	140
			338/29338	4000/8800	1.1	274/23783	4000/8800	1.21	3-618/10-273	86	142
			338/29338	4000/8800	1.25	274/23783	4000/8800	1.50	3-618/13-273	87	143
3.7	5	5	410/35588	4000/8800	<1.0	410/35588	4000/8800	<1.0	5-618/13-273	87	143
			552/47914	5400/11880	1.05	460/39928	5400/11880	1.17	5-619/11-273	88	144
			552/47914	5400/11880	1.32	460/39928	5400/11880	1.59	5-619/13-273	89	145
5.5	7.5	8	730/86634	5400/11880	<1.0	684/59371	5400/11880	1.07	8-619/13-273	89	145
			821/71263	8800/19360	1.18	684/59371	8800/19360	1.42	8-621/13-273	92	148
			821/71263	12000/26400	1.55	684/59371	11900/26180	1.71	8-622/13-273	94	150
7.5	10	10	965/83762	8800/19360	<1.0	933/80984	8800/19360	1.04	10-621/13-273	92	148
			1119/97129	12000/26400	1.14	933/80984	11900/26180	1.36	10-622/17-273	95	151
			1119/97129	15000/33000	1.44	933/80984	14000/30800	1.69	10-623/16-273	96	152
11	15	15	1275/110670	12000/26400	<1.0	1268/110062	11900/26180	<1.0	15-622/17-273	95	151
			1620/140616	15000/33000	<1.0	1368/118742	14000/30800	1.15	15-623/16-273	96	152
			1642/142526	16700/36740	1.24	1368/118742	16000/35200	1.47	15-624/16-273	98	154
15	20	20	2050/177940	16700/36740	<1.0	1865/161882	16000/35200	1.08	20-624/16-273	98	154
			2239/194345	20400/44880	1.19	1965/161882	19400/42680	1.42	20-625/17-273	100	156
			2239/194345	24900/54780	1.56	1965/161882	23700/52140	1.86	20-626/19-273	102	158
18.5	25	25	2650/230020	20400/44880	<1.0	2325/202042	19400/42680	1.15	25-625/17-273	100	156
			2761/239655	24900/54780	1.26	2330/202477	23700/52140	1.51	25-626/19-273	102	158
22	30	30	2650/230020	20400/44880	<1.0	2650/230020	19400/42680	1.0	30-625/17-273	100	156
			3283/284964	24900/54780	1.06	2736/237485	23700/52140	1.27	30-626/19-273	102	158
30	40	40	3500/303800	24900/54780	<1.0	3470/301196	23700/52140	1.0	40-626/06-273	102	158

Ratio	Frequency	Motor Input Speed	Reducer Output Speed
319 (29x11)	50 Hz	1500 R.P.M.	4.7 R.P.M.
	60 Hz	1800 R.P.M.	5.6 R.P.M.

MOTOR			50Hz			60Hz			TRANSCYKO MODEL	Dimension page	
KW	HP	SYMBOL	Output Torque kgf·m / in·lbs	Allowable Output Shaft Overhung load kgf / lbs	S.F.	Output Torque kgf·m / in·lbs	Allowable Output Shaft Overhung load kgf / lbs	S.F.		H	V
0.2	1/4	02	26.0/2257	550/1210	<1.0	26.0/2257	550/1210	<1.0	02-610/08-319	71	127
			34.9/3029	880/1936	1.45	29.1/2526	880/1936	1.75	02-611/08-319	72	128
0.4	1/2	05	51.0/4427	880/1936	<1.0	51.0/4427	880/1936	<1.0	05-611/08-319	72	128
			69.8/6059	1365/3003	1.10	58.1/5043	1365/3003	1.32	05-613/09-319	75	131
			69.8/6059	1500/3300	1.48	58.1/5043	1500/3300	1.78	05-614/09-319	78	134
0.75	1	1	77.0/6684	1365/3003	<1.0	77.0/6684	1365/3003	<1.0	1-613/09-319	75	131
			103/8940	1500/3300	<1.0	103/8940	1500/3300	<1.0	1-614/09-319	78	134
			131/11371	2050/4510	1.40	109/9461	2050/4510	1.65	1-616/09-319	80	136
1.5	2	2	183/15884	2050/4510	<1.0	183/15884	2050/4510	<1.0	2-616/10-319	81	137
			262/22742	2900/6380	1.06	218/18922	2900/6380	1.23	2-617/10-319	84	140
			262/22742	4000/8800	1.57	218/18922	4000/8800	1.75	2-618/10-319	86	142
2.2	3	3	278/24130	2900/6380	<1.0	269/23349	2900/6380	<1.0	3-617/10-319	84	140
			278/24130	2900/6380	<1.0	278/24130	2900/6380	<1.0	3-617/10-319	85	141
			384/33331	4000/8800	1.07	320/27776	4000/8800	1.20	3-618/10-319	86	142
			384/33331	4000/8800	1.1	320/27776	4000/8800	1.28	3-618/13-319	87	143
			384/33331	5400/11880	1.62	320/27776	5400/11880	1.69	3-619/11-319	88	144
3.7	5	5	410/35588	4000/8800	<1.0	410/35588	4000/8800	<1.0	5-618/13-319	87	143
			645/55986	5400/11880	1.13	538/46698	5400/11880	1.31	5-619/13-319	89	145
			648/55986	8800/19360	1.49	538/46698	8800/19360	1.79	5-621/13-319	92	148
5.5	7.5	8	730/63364	5400/11880	<1.0	703/61020	5400/11886	<1.0	8-619/13-319	89	145
			959/83241	8800/19360	1.04	799/69353	8800/19360	1.21	8-621/13-319	92	148
			959/83214	12300/27060	1.33	799/69353	12000/26400	1.55	8-622/13-319	94	150
7.5	10	10	965/83762	8800/19360	<1.0	965/83762	8800/19360	<1.0	10-621/13-319	92	148
			1275/110670	12300/27060	<1.0	1090/94612	12000/26400	1.13	10-622/13-319	94	150

\*When S.F. marked as <1, overload may occur if the motor is loaded to its full KW (HP) capacity, in which case it must be used within the values stipulated in the output torque column.



MOTOR			50Hz			60Hz			TRANSCYKO MODEL	Dimension page	
KW	HP	SYMBOL	Output Torque kgf. m / in. lbs	Allowable Output Shaft Overhung load kgf / lbs	S.F.	Output Torque kgf. m / in. lbs	Allowable Output Shaft Overhung load kgf / lbs	S.F.		H	V
7.5	10	10	1308/113534	15400/33880	1.20	1090/94612	15000/33000	1.39	10-623/16-319	96	152
11	15	15	1275/110670	12300/27060	<1.0	1238/107458	12000/26400	<1.0	15-622/17-319	95	151
			1570/136276	15400/33880	<1.0	1511/131155	15000/33000	<1.0	15-623/16-319	96	152
			1918/166482	17000/37400	1.05	1600/138880	16700/36740	1.19	15-624/16-319	98	154
			1918/166482	21000/46200	1.38	1600/138880	20400/44880	1.65	15-625/17-319	100	156
15	20	20	2030/176204	17000/37400	<1.0	1970/170996	16700/36740	<1.0	20-624/18-319	99	155
			2616/227069	21000/46200	1.01	2200/190960	20400/44880	1.21	20-625/17-319	100	156
			2616/227069	25700/56540	1.34	2200/190960	24900/54780	1.53	20-626/19-319	102	158
18.5	25	25	2650/230020	21000/46200	<1.0	2650/230020	20300/44660	<1.0	25-625/17-319	100	156
			3226/280017	25700/56540	1.09	2688/233318	24900/54780	1.24	25-626/19-319	102	158
			3226/280017	20000/44000	1.83	2688/233318	20000/44000	2.05	25-627/19-319	103	159
22	30	30	3500/303800	25700/56540	<1.0	3197/277500	24900/54780	1.04	30-626/19-319	102	158
			3836/332965	20000/44000	1.54	3197/277500	20000/44000	1.72	30-627/19-319	103	159
30	40	40	5300/460570	20000/44000	1.13	4360/378448	20000/44000	1.26	40-627/19-319	103	159
37	50	50	5900/512120	20000/44000	<1.0	5377/466724	20000/44000	1.02	50-627/19-319	103	159

Ratio	Frequency	Motor Input Speed	Reducer Output Speed
377 (29x13)	50 Hz	1500 R.P.M.	4.0 R.P.M.
	60 Hz	1800 R.P.M.	4.8 R.P.M.

MOTOR			50Hz			60Hz			TRANSCYKO MODEL	Dimension page	
KW	HP	SYMBOL	Output Torque kgf. m / in. lbs	Allowable Output Shaft Overhung load kgf / lbs	S.F.	Output Torque kgf. m / in. lbs	Allowable Output Shaft Overhung load kgf / lbs	S.F.		H	V
0.2	1/4	02	26.0/2257	550/1210	<1.0	25.8/2242	550/1210	<1.0	02-610/08-377	71	127
			41.2/3576	880/1936	1.25	35.0/3042	880/1936	1.50	02-611/08-377	72	128
0.4	1/2	05	51.0/4427	880/1936	<1.0	51.5/4475	880/1936	<1.0	05-611/08-377	72	128
			77.0/6684	1365/3003	<1.0	69.1/6005	1365/3003	1.15	05-613/09-377	75	131
			82.4/7152	1500/3300	1.25	69.5/6040	1500/3300	1.50	05-614/09-377	78	134
0.75	1	1	77.0/6684	1365/3003	<1.0	77.5/6735	1365/3003	<1.0	1-613/09-377	75	131
			103/8940	1500/3300	<1.0	104/9038	1500/3300	<1.0	1-614/09-377	78	134
			154/13367	2050/4510	1.19	135/11732	2050/4510	1.41	1-616/09-377	80	136
			154/13367	2900/6380	1.80	135/11732	2900/6380	2.16	1-617/10-377	84	140
1.5	2	2	18.1/15884	2050/4510	<1.0	183/15903	2050/4510	<1.0	2-616/10-377	81	137
			278/24130	2900/6380	<1.0	365/23028	2900/6380	1.08	2-617/10-377	84	140
2.2	3	3	309/26821	4000/8800	1.33	265/23028	4000/8800	1.59	2-618/10-377	86	142
			410/35588	4000/8800	<1.0	385/33456	4000/8800	1.07	3-618/10-377	86	142
3.7	5	5	453/39320	5400/11880	1.61	385/33456	5400/11880	1.93	3-619/13-377	89	145
			730/63364	5400/11880	<1.0	645/56050	5400/11880	1.15	5-619/13-377	89	145
5.5	8	8	762/66142	8800/19360	1.26	645/56050	8800/19360	1.53	5-621/13-377	92	148
			730/63364	5400/11880	<1.0	735/63872	5400/11880	<1.0	8-619/13-377	89	145
7.5	10	10	965/83762	8800/1936	<1.0	960/83424	8800/19360	1.03	8-621/13-377	92	148
			1134/98431	1320/29040	1.12	960/83424	12300/27060	1.32	8-622/17-377	95	151
			134/98431	16300/35860	1.43	965/83858	15400/33880	1.65	8-623/16-377	96	152
11	15	15	1275/110670	13200/29040	<1.0	1290/112101	12300/27060	<1.0	10-622/17-377	95	151
			1546/134193	16300/35860	1.05	1300/112970	15400/33880	1.21	10-623/16-377	96	152
			1546/134193	18500/40700	1.33	1300/112970	17000/37400	1.55	10-624/16-377	98	154
15	20	20	1620/140616	16300/35860	<1.0	1600/139040	15400/33880	<1.0	15-623/16-377	96	152
			2050/177940	18500/40700	<1.0	1920/166848	17000/37400	1.05	15-624/16-377	98	154
			2267/196776	22000/48400	1.16	1920/166848	21000/46200	1.40	15-625/17-377	100	156
			2267/196776	27300/60060	1.54	1920/166848	25700/56540	1.85	15-626/19-377	102	158
18.5	25	25	2650/230020	22000/48400	<1.0	2595/225506	21000/46200	1.03	20-625/17-377	100	156
			3091/268299	27300/60060	1.13	2605/226374	25700/56540	1.36	20-626/19-377	102	158
			3091/268299	20000/44000	1.99	2605/226374	20000/40000	2.25	20-627/19-377	103	159
22	30	30	3500/303800	27300/60060	<1.0	3210/278949	25700/56540	1.10	25-626/19-377	102	158
			3813/330968	20000/44000	1.61	3215/279384	20000/44000	1.83	25-627/19-377	103	159
30	40	40	3500/303800	27300/60060	<1.0	3520/305888	25700/56540	<1.0	30-626/19-377	102	158
			4534/393551	20000/44000	1.35	3830/332827	20000/44000	1.54	30-627/19-377	103	159
37	50	50	6150/533820	20000/44000	<1.0	5220/453618	20000/44000	1.13	40-627/19-377	103	159

\*When S.F. marked as <1, overload may occur if the motor is loaded to its full KW (HP) capacity, in which case it must be used within the values stipulated in the output torque column.



Ratio	Frequency	Motor Input Speed	Reducer Output Speed
473 (43x11)	50 Hz	1500 R.P.M.	3.2 R.P.M.
	60 Hz	1800 R.P.M.	3.8 R.P.M.

MOTOR			50Hz			60Hz			TRANSCYKO MODEL	Dimension page	
KW	HP	SYMBOL	Output Torque kgf. m / in-lbs	Allowable Output Shaft Overhung load kgf / lbs	S.F.	Output Torque kgf. m / in-lbs	Allowable Output Shaft Overhung load kgf / lbs	S.F.		H	V
0.2	1/4	02	51.7/4488	880/1936	1.00	43.1/3741	880/1936	1.20	02-610/08-473	72	128
			51.7/4488	1350/2970	1.50	43.1/3741	1365/3003	1.80	02-613/08-473	74	130
0.4	1/2	05	51.0/4427	880/1936	<1.0	51.0/4427	880/1936	<1.0	05-611/08-473	72	128
			77.0/6684	1365/3003	<1.0	77.0/6684	1365/3003	<1.0	05-613/08-473	75	130
			103/8940	1500/3300	1.00	86.2/7482	1500/3300	1.20	05-614/09-473	78	134
			103/8940	2050/4510	1.78	86.2/7482	2050/4510	2.12	05-616/09-473	80	136
0.75	1	1	103/8940	1500/3300	<1.0	103/8940	1500/3300	<1.0	1-614/09-473	78	134
			183/15884	2050/4510	<1.0	162/14062	2050/4510	1.13	1-616/09-473	80	136
			194/16839	2900/6380	1.44	162/14062	2900/6380	1.59	1-617/09-473	83	139
1.5	2	2	279/24130	2900/6380	<1.0	277/24044	2900/6380	<1.0	2-617/10-473	84	140
			388/33678	4000/8800	1.05	323/28036	4000/8800	1.27	2-618/10-473	80	142
			388/33678	5400/11880	1.52	323/28036	5400/11880	1.92	2-619/11-473	88	144
2.2	3	3	410/35588	4000/8800	<1.0	410/35588	4000/8800	<1.0	3-618/10-473	86	142
			569/49389	5400/11880	1.04	474/41143	5400/11880	1.31	3-619/11-473	88	144
			569/49389	5400/11880	1.28	474/42143	5400/11880	1.54	3-619/13-473	89	145
3.7	5	5	730/63364	5400/11880	<1.0	730/63364	5400/11880	<1.0	5-619/13-473	89	145
			855/74214	8000/17600	<1.0	797/69180	8000/17600	1.07	5-620/13-473	91	147
			957/83068	8800/19360	1.18	797/69180	8800/19360	1.42	5-621/13-473	92	148
			957/83068	14300/31460	1.50	797/70180	13200/29040	1.79	5-622/13-473	94	150
5.5	7.5	8	855/74214	8000/17600	<1.0	851/73867	8000/17600	<1.0	8-620/13-473	91	147
			1130/98084	8800/19360	<1.0	1130/98084	8800/19360	<1.0	8-621/13-473	92	148
			1422/123430	14300/31460	1.01	1185/102858	13200/29040	1.20	8-622/13-473	94	150
			1422/123430	18000/39600	1.28	1185/102858	16300/35860	1.48	8-623/16-473	96	152
7.5	10	10	1440/124992	14300/31460	<1.0	1429/124037	13200/29040	<1.0	10-622/13-473	94	150
			1825/158410	18000/39600	<1.0	1616/140269	16300/35860	1.09	10-623/16-473	96	152
			1939/168305	19500/42900	1.21	1616/140269	18500/40700	1.43	10-624/16-473	198	154
			1939/168305	24000/52800	1.57	1616/140269	22000/48400	1.89	10-625/17-473	100	156
11	15	15	2350/203980	19500/42900	<1.0	2310/200508	18500/40700	<1.0	15-624/16-473	98	154
			2844/246859	24000/52800	1.07	2370/205716	22000/48400	1.29	15-625/17-473	100	156
			2844/246859	27800/61160	1.45	2370/205716	27300/60060	1.69	15-626/19-473	102	158
15	20	20	3050/264740	24000/52800	<1.0	3050/264740	22000/48400	<1.0	20-625/17-473	100	156
			3879/336697	27800/61160	1.07	3232/280538	27300/60060	1.23	20-626/19-473	102	158
			3879/336697	20000/61820	1.59	3232/280538	20000/44000	1.78	20-627/19-473	103	159
18.5	25	25	4140/359352	27800/61160	<1.0	3986/345985	27300/60060	<1.0	25-626/19-473	102	158
			4784/415251	20000/44000	1.29	3986/355985	20000/44000	1.44	25-627/19-473	103	159
22	30	30	5689/493805	20000/44000	1.08	4740/411432	20000/44000	1.21	30-627/19-473	103	159
30	40	40	6150/533820	20000/44000	<1.0	5753/499360	20000/44000	<1.0	40-627/19-473	103	159

Ratio	Frequency	Motor Input Speed	Reducer Output Speed
559 (43x13)	50 Hz	1500 R.P.M.	2.7 R.P.M.
	60 Hz	1800 R.P.M.	3.2 R.P.M.

MOTOR			50Hz			60Hz			TRANSCYKO MODEL	Dimension page	
KW	HP	SYMBOL	Output Torque kgf. m / in-lbs	Allowable Output Shaft Overhung load kgf / lbs	S.F.	Output Torque kgf. m / in-lbs	Allowable Output Shaft Overhung load kgf / lbs	S.F.		H	V
0.2	1/4	02	51.0/4427	880/1936	<1.0	50.9/4418	880/1936	1.00	02-611/08-559	72	128
			61.1/5303	1365/3003	1.25	50.9/4418	1365/3003	1.50	02-613/08-559	74	130
0.4	1/2	05	77.0/6684	1365/3003	<1.0	77.0/6684	1365/3003	<1.0	05-613/08-559	74	130
			103/8940	1500/3300	<1.0	102/8854	1500/3300	1.00	05-614/08-559	77	133
			122/10590	2050/4510	1.50	102/8854	2050/4510	1.80	05-616/09-559	180	136
			183/15884	2050/4510	<1.0	183/15884	2050/4510	<1.0	1-616/09-559	80	136
0.75	1	1	229/19877	2900/6380	1.21	191/16579	2900/6380	1.41	1-617/09-559	183	139
			229/19877	4000/8800	1.79	191/16579	4000/8800	2.15	1-618/10-559	186	142

\*When S.F. marked as < 1, overload may occur if the motor is loaded to its full KW (HP) capacity, in which case it must be used within the values stipulated in the output torque column.



MOTOR			50Hz			60Hz			TRANSCYKO MODEL	Dimension page	
KW	HP	SYMBOL	Output Torque kgf·m / in·lbs	Allowable Output Shaft Overhung load kgf / lbs	S.F.	Output Torque kgf·m / in·lbs	Allowable Output Shaft Overhung load kgf / lbs	S.F.		H	V
1.5	2	2	278/24130	2900/6380	<1.0	277/24044	2900/6380	<1.0	2-617/10-559	84	140
			410/35588	4000/8800	<1.0	382/33158	4000/8800	1.07	2-618/10-559	86	142
			458/39754	5400/11880	1.33	382/33158	5400/11880	1.56	2-619/11-559	88	144
2.2	3	3	610/52948	5400/11880	<1.0	560/48668	5400/11880	1.06	3-619/11-559	88	144
			672/58330	5400/11880	1.09	560/48608	5400/11880	1.30	3-619/13-559	89	145
			672/58330	8000/17600	1.27	560/48608	8000/11880	1.50	3-620/13-559	91	147
3.7	5	5	730/63364	5400/11880	<1.0	730/63364	5400/11760	<1.0	5-619/13-559	89	145
			855/74214	8000/17600	<1.0	840/72912	8800/11880	<1.0	5-620/13-559	91	147
			1131/98171	8800/19360	1.00	942/81766	8800/17600	1.20	5-621/13-559	92	148
			1131/98171	14300/31460	1.27	942/81766	14300/19360	1.52	5-622/13-559	94	150
5.5	7.5	8	1440/124992	14300/31460	<1.0	1401/121607	14300/31460	1.02	8-622/13-559	94	150
			1681/145911	18000/39600	1.08	1401/124607	18000/39600	1.30	8-623/16-559	96	152
			1681/145911	19500/42900	1.40	1400/121607	19500/42900	1.69	8-624/16-559	98	154
7.5	10	10	1825/158410	18000/39600	<1.0	1820/157976	18000/39600	<1.0	10-623/16-559	96	152
			2292/198946	19500/42900	1.02	1910/165788	19500/42900	1.24	10-624/16-559	98	154
			2292/198946	24000/52800	1.33	1910/165788	24000/52800	1.59	10-625/17-559	100	156
11	15	15	3050/264740	24000/52800	<1.0	2801/243127	24000/52800	1.08	15-625/17-559	100	156
			3361/291735	27800/61160	1.23	2801/243127	27800/61160	1.46	15-626/19-559	102	158
			3361/291735	20000/44000	1.83	2801/243127	20000/44000	2.18	15-627/19-559	103	159
15	20	20	4140/359352	27800/61600	<1.0	3820/331576	27800/61160	1.07	20-626/19-559	102	158
			4584/397891	20000/44000	1.34	3820/331576	20000/44000	1.60	20-627/19-559	103	159
18.5	25	25	5653/490680	20000/44000	1.09	4711/408915	20000/44000	1.30	25-627/19-559	103	159
22	30	30	6150/533820	20000/40000	<1.0	5602/486254	20000/44000	1.09	30-627/19-559	103	159

Ratio	Frequency	Motor Input Speed	Reducer Output Speed
649 (59x11)	50 Hz	1500 R.P.M.	2.3 R.P.M.
	60 Hz	1800 R.P.M.	2.8 R.P.M.

MOTOR			50Hz			60Hz			TRANSCYKO MODEL	Dimension page	
KW	HP	SYMBOL	Output Torque kgf·m / in·lbs	Allowable Output Shaft Overhung load kgf / lbs	S.F.	Output Torque kgf·m / in·lbs	Allowable Output Shaft Overhung load kgf / lbs	S.F.		H	V
0.2	1/4	02	51.0/4427	880/1936	<1.0	51.0/4427	880/1936	<1.0	02-611/08-649	72	128
			59.1/6213	1365/3003	1.10	59.1/5130	1365/3003	1.30	02-613/08-649	74	130
			59.1/6274	1500/3300	1.45	59.1/5130	1500/3300	1.75	02-614/08-649	77	133
0.4	1/2	05	77.0/6684	1365/3003	<1.0	77.0/6684	1365/3003	<1.0	05-613/08-649	74	130
			103/8940	1500/3300	<1.0	103/8940	1500/3300	<1.0	05-614/08-649	77	133
			142/12326	2050/4510	1.30	118/10242	2050/4510	1.55	05-616/09-649	80	136
0.75	1	1	183/15884	2050/4510	<1.0	183/15884	2050/4510	<1.0	1-616/09-649	80	136
			266/23089	2900/6380	1.04	222/19270	2900/6380	1.20	1-617/09-649	83	139
			266/23089	4000/8800	1.55	222/19270	4000/8800	1.84	1-618/10-649	86	142
1.5	2	2	278/24130	2900/6380	<1.0	276/23957	2900/6380	<1.0	2-617/10-649	84	140
			410/35588	4000/880	<1.0	408/35588	4000/8800	<1.0	2-618/10-649	86	142
			532/46178	5400/11880	1.19	443/38452	5400/11800	1.37	2-619/11-649	88	144
2.2	3	3	630/54684	5400/11880	<1.0	610/52948	5400/11800	<1.0	3-619/11-649	88	144
			780/67704	8000/17600	1.10	650/56420	8000/17600	1.29	3-620/13-649	91	147
			780/67704	8800/19360	1.44	650/56420	88000/19360	1.74	3-621/13-649	92	148
3.7	5	5	630/54684	5400/1880	<1.0	610/57354	5400/11880	<1.0	5-619/11-649	88	144
			855/74214	800/17600	<1.0	840/72912	8000/17600	<1.0	5-620/13-649	91	147
			1130/98084	8800/19360	<1.0	1094/94959	8800/19360	1.04	5-621/13-649	92	148
			1313/113968	14700/32340	1.10	1094/94959	14300/31460	1.31	5-622/13-649	94	150
			1313/113968	18000/36960	1.39	1094/94959	18000/3960	1.62	5-623/16-649	96	152
5.5	7.5	8	1440/124992	14700/32340	<1.0	1430/124124	14300/31460	<1.0	8-622/13-649	94	150
			1825/158410	18000/39600	<1.0	1626/141137	18000/39600	1.09	8/-623/16-649	96	152
			1951/169347	21000/46200	1.20	1626/141137	19500/42900	1.41	8-624/16-649	98	154
			1951/169347	26000/57200	1.56	1626/141137	24000/52800	1.87	8-625/17-649	100	156
7.5	10	10	2350/203980	21000/46200	<1.0	2217/192436	19500/42900	1.04	10-624/16-649	98	154
			2661/230975	26000/57200	1.15	2217/192436	24000/52800	1.37	10-625/17-649	100	156
			2661/230975	27800/61160	1.56	2217/192436	27800/61160	1.80	10-626/19-649	102	158
11	15	15	3050/264740	26000/57200	<1.0	3050/264740	24000/52800	<1.0	15-625/17-649	100	156
			3903/338780	27800/61160	1.06	3252/282274	27800/61160	1.23	15-626/19-649	102	158

\*When S.F. marked as <1, overload may occur if the motor is loaded to its full KW (HP) capacity, in which case it must be used within the values stipulated in the output torque column.



MOTOR			50Hz			60Hz			TRANSCYKO MODEL	Dimension page	
KW	HP	SYMBOL	Output Torque kgf·m / in·lbs	Allowable Output Shaft Overhung load kgf / lbs	S.F.	Output Torque kgf·m / in·lbs	Allowable Output Shaft Overhung load kgf / lbs	S.F.		H	V
11	15	15	3903/338780	20000/44000	1.57	3252/282274	20000/44000	1.83	15-627/19-649	103	159
15	20	20	4140/359766	27800/61160	<1.0	4000/347600	27800/61160	<1.0	20-626/19-649	102	159
			5322/461950	20000/44000	1.15	4435/384958	20000/44000	1.34	20-627/19-649	103	159
18.5	25	25	6150/533820	20000/44000	<1.0	5470/474796	20000/44000	1.09	25-627/19-649	103	159
22	30	30	6150/533820	20000/44000	<1.0	5950/516460	20000/44000	<1.0	30-627/19-649	103	159

Ratio	Frequency	Motor Input Speed	Reducer Output Speed
731 (43x17)	50 Hz	1500 R.P.M.	2.1 R.P.M.
	60 Hz	1800 R.P.M.	2.5 R.P.M.

MOTOR			50Hz			60Hz			TRANSCYKO MODEL	Dimension page	
KW	HP	SYMBOL	Output Torque kgf·m / in·lbs	Allowable Output Shaft Overhung load kgf / lbs	S.F.	Output Torque kgf·m / in·lbs	Allowable Output Shaft Overhung load kgf / lbs	S.F.		H	V
0.2	1/4	02	51.0/4427	880/1936	<1.0	51.0/4427	880/1936	<1.0	02-611/08-731	72	128
			79.9/6935	1365/3003	1.00	66.6/5781	1365/3003	1.35	02-613/08-731	74	130
			79.9/6935	1500/3300	1.30	66.6/5781	1500/3300	1.55	02-614/08-731	77	133
0.4	1/2	05	77.0/6684	1365/3003	<1.0	77.1/6684	1365/3003	<1.0	05-613/08-731	74	130
			103/8940	1500/3300	<1.0	102/8854	1500/3300	<1.0	05-614/08-731	77	133
			160/13888	2050/4510	1.15	133/11544	2050/4510	1.38	05-616/09-731	80	136
0.75	1	1	160/13888	2900/6380	1.75	133/11544	2900/6380	2.08	05-617/09-731	83	139
			183/15884	2050/4510	<1.0	183/15884	2050/4510	<1.0	1-616/09-731	80	136
			278/24130	2900/6380	<1.0	250/21700	2900/6380	1.11	1-617/09-731	83	139
1.5	2	2	300/26040	4000/8800	1.36	250/21700	4000/8800	1.64	1-618/10-731	86	142
			410/35588	4000/8800	<1.0	410/35588	4000/8800	<1.0	2-618/10-731	86	142
			599/51993	5400/11880	1.13	500/43400	5400/11880	1.26	2-619/11-731	88	144
2.2	3	3	599/51993	8000/17600	1.47	500/43400	8000/17600	1.68	2-620/13-731	91	147
			680/59024	5400/11880	<1.0	631/54771	5400/11880	<1.0	3-619/11-731	88	144
			879/76297	8800/19360	1.29	733/63624	8800/19360	1.54	3-621/13-731	92	148
3.7	5	5	855/74214	8000/17600	<1.0	840/72912	8000/17600	<1.0	5-620/13-731	91	147
			1130/98084	8800/19360	<1.0	1136/98587	8800/19360	<1.0	5-621/13-731	92	148
			1440/124992	14700/32340	<1.0	1232/106938	14500/31900	1.17	5-622/13-731	94	150
			1478/128290	18000/39600	1.24	1232/106938	18000/39600	1.48	5-623/16-731	96	152
5.5	7.5	8	1440/124992	14700/32340	<1.0	1440/124992	14500/31900	<1.0	8-622/13-731	94	150
			1825/158410	18000/39600	<1.0	1832/159018	18000/39600	1.00	8-623/16-731	96	152
			2198/190786	21000/46200	1.07	1832/159018	20200/44440	1.29	8-624/16-731	98	154
			2198/190786	26000/57200	1.39	2368/159018	18200/40040	1.66	8-625/17-731	100	156
7.5	10	10	2350/203980	21000/46200	<1.0	2498/205542	20200/44440	<1.0	10-624/16-731	98	154
			2997/260140	26000/57200	1.02	2498/216826	25000/55000	1.22	10-625/17-731	100	156
			2997/260140	27800/61160	1.39	2498/216826	27800/61160	1.64	10-626/19-731	102	158
11	15	15	3050/264740	26000/57200	<1.0	3050/264740	26000/57200	<1.0	15-625/17-731	100	156
			4140/359352	27800/61160	<1.0	3663/317948	27800/61160	1.12	15-626/19-731	102	158
			4396/381573	20000/44000	1.40	3663/317948	20000/44000	1.67	15-627/19-731	103	159
15	20	20	4140/359352	27800/61160	<1.0	4100/355880	27800/61160	<1.0	20-626/19-731	102	158
			5994/520279	20000/44000	1.03	4995/433566	20000/44000	1.23	20-627/19-731	103	159
18.5	25	25	6150/533820	20000/44000	<1.0	6161/534775	20000/44000	1.00	25-627/19-731	103	159
22	30	30	6150/533820	20000/44000	<1.0	6140/532952	20000/44000	<1.0	30-627/19-731	103	159

Ratio	Frequency	Motor Input Speed	Reducer Output Speed
841 (29x29)	50 Hz	1500 R.P.M.	1.8 R.P.M.
	60 Hz	1800 R.P.M.	2.1 R.P.M.

MOTOR			50Hz			60Hz			TRANSCYKO MODEL	Dimension page	
KW	HP	SYMBOL	Output Torque kgf·m / in·lbs	Allowable Output Shaft Overhung load kgf / lbs	S.F.	Output Torque kgf·m / in·lbs	Allowable Output Shaft Overhung load kgf / lbs	S.F.		H	V
0.2	1/4	02	51.0/4427	880/1936	<1.0	51.0/4427	880/1936	<1.0	02-611/08-841	72	128
			91.9/7977	1350/2970	1.00	76.6/6649	1365/3003	1.00	02-613/08-841	74	130
			91.9/7977	1500/3300	1.10	76.6/6649	1500/3300	1.25	02-614/09-841	78	134
			91.9/7977	2050/4510	2.00	76.6/6649	2050/4510	2.40	02-616/09-841	80	136

\*When S.F. marked as <1, overload may occur if the motor is loaded to its full KW (HP) capacity, in which case it must be used within the values stipulated in the output torque column.



Ratio	Frequency	Motor Input Speed	Reducer Output Speed
841 (29x29)	50 Hz	1500 R.P.M.	1.8 R.P.M.
	60 Hz	1800 R.P.M.	2.1 R.P.M.

MOTOR			50Hz			60Hz			TRANSCYKO MODEL	Dimension page	
KW	HP	SYMBOL	Output Torque kgf·m / in·lbs	Allowable Output Shaft Overhung load kgf / lbs	S.F.	Output Torque kgf·m / in·lbs	Allowable Output Shaft Overhung load kgf / lbs	S.F.		H	V
0.4	1/2	05	103/8940	1500/3300	<1.0	103/8940	1500/3300	<1.0	05-614/09-841	78	134
			184/15971	2050/4510	1.00	153/13280	2050/4510	1.20	05-616/09-841	80	136
			184/15971	2900/6380	1.50	153/13280	2900/6380	1.72	05-617/09-841	83	139
0.75	1	1	183/15884	2050/4510	<1.0	183/15884	2050/4510	<1.0	1-616/09-841	80	136
			278/24130	2900/6380	<1.0	277/27044	2900/6380	<1.0	1-617/10-841	84	140
			345/29946	4000/8800	1.19	287/24912	4000/8800	1.43	1-618/10-841	86	142
1.5	2	2	345/29946	5400/11880	2.12	287/24912	5400/11880	2.52	1-619/11-841	88	144
			410/35588	4000/8800	<1.0	410/35588	4000/8800	<1.0	2-618/10-841	86	142
			695/59892	5400/11880	1.06	575/49910	5400/11880	1.26	2-619/11-841	88	144
2.2	3	3	690/59892	8800/19360	1.47	575/49910	8800/19360	1.67	2-620/13-841	92	148
			730/83364	5400/11880	<1.0	725/62930	5400/11880	<1.0	3-619/11-841	88	144
			1011/87755	8800/19360	1.00	843/73172	8800/19360	1.14	3-621/13-841	92	148
3.7	5	5	1011/87755	1470/32340	1.24	843/73172	14700/32340	1.60	3-622/13-841	94	150
			1250/108500	1470/39600	<1.0	1345/116746	14700/32340	<1.0	5-622/13-841	94	150
			1640/142352	18000/46200	<1.0	1418/123082	18000/39600	1.14	5-623/16-841	96	152
			1701/147647	21000/57200	1.20	1418/123082	21000/46200	1.48	5-624/16-841	98	154
5.5	7.5	8	1701/147647	26000/40040	1.58	1418/123082	26000/57200	1.90	5-625/17-841	100	156
			1640/142352	18000/39600	<1.0	1624/140963	18000/39600	<1.0	8-623/16-841	96	152
			2050/177940	21000/46200	<1.0	2100/182228	21000/46200	<1.0	8-624/16-841	98	154
			2529/219517	26000/57200	1.06	2135/185532	26000/57200	1.28	8-625/17-841	100	156
7.5	10	10	2529/219517	27800/61160	1.40	2135/185532	27800/61160	1.71	8-626/19-841	102	158
			2695/233926	26000/57200	<1.0	2690/233492	26000/57200	<1.0	10-625/17-841	100	156
			3448/299286	27800/61160	1.03	2873/249376	27800/61160	1.25	10-626/19-841	102	158
			3448/299286	22000/44000	1.79	2873/249376	22000/44000	2.13	10-627/19-841	103	159
11	15	15	3540/307272	27800/61160	<1.0	3600/312480	27800/61160	<1.0	15-626/19-841	102	158
			5057/438948	20000/44000	1.22	4214/365775	20000/44000	1.45	15-627/19-841	103	159
15	20	20	6150/533820	20000/44000	<1.0	5747/498840	20000/44000	1.07	20-627/19-841	103	159
18.5	25	25	6150/533820	20000/44000	<1.0	6150/533820	20000/44000	<1.0	25-627/19-841	103	159
22	30	30	6150/533820	20000/44000	<1.0	6150/533820	20000/44000	<1.0	30-627/19-841	103	159

Ratio	Frequency	Motor Input Speed	Reducer Output Speed
1003 (59x17)	50 Hz	1500 R.P.M.	1.5 R.P.M.
	60 Hz	1800 R.P.M.	1.8 R.P.M.

MOTOR			50Hz			60Hz			TRANSCYKO MODEL	Dimension page	
KW	HP	SYMBOL	Output Torque kgf·m / in·lbs	Allowable Output Shaft Overhung load kgf / lbs	S.F.	Output Torque kgf·m / in·lbs	Allowable Output Shaft Overhung load kgf / lbs	S.F.		H	V
0.2	1/4	02	51.0/4427	880/1936	<1.0	51.0/4427	880/1936	<1.0	02-611/08-1003	72	128
			77.0/6684	1365/3003	<1.0	77.0/6684	1365/3003	<1.0	02-613/08-1003	74	130
			103/8940	1500/3300	<1.0	91.4/7934	1500/3300	1.10	02-614/08-1003	77	133
			110/9548	2050/4510	1.67	91.4/7934	2050/4510	1.67	02-616/09-1003	80	136
0.4	1/2	05	103/8940	1500/3300	<1.0	103/8940	1500/3300	<1.0	05-614/08-1003	77	133
			183/15884	2050/4510	<1.0	183/15884	2050/4510	<1.0	05-616/09-1003	80	136
			219/19009	2900/6380	1.28	183/15884	2900/6380	1.52	05-617/09-1003	83	139
0.75	1	1	278/24130	2900/6380	<1.0	278/24130	2900/6380	<1.0	1-617/09-1003	83	139
			411/35675	4000/8800	1.00	343/29772	4000/8800	1.20	1-618/10-1003	86	142
			411/35675	5400/11880	1.75	343/29772	5400/11880	1.91	1-619/11-1003	88	144
1.5	2	2	410/35588	4000/880	<1.0	410/35588	4000/8800	<1.0	2-618/10-1003	86	142
			720/62496	5400/11880	<1.0	653/56680	5400/11880	<1.0	2-619/11-1003	88	144
			822/71350	8000/17600	1.02	685/59458	8000/17600	1.22	2-620/13-1003	91	147
			822/71350	8800/19360	1.37	685/59458	8800/19360	1.66	2-621/13-1003	92	148
2.2	3	3	720/62496	5400/11880	<1.0	653/56680	5400/11880	<1.0	3-619/11-1003	88	144
			840/72912	8000/17600	<1.0	840/72912	8000/17600	1.0	3-620/13-1003	91	147
			1130/98084	8800/19360	<1.0	1005/87234	8800/19360	1.13	3-621/13-1003	92	148
			1206/104681	14700/32340	1.20	1005/87234	14700/32340	1.43	3-622/13-1003	94	150
			1206/104681	18000/39600	1.51	1005/87234	18000/39600	1.81	3-623/16-1003	96	152

\*When S.F. marked as < 1, overload may occur if the motor is loaded to its full KW (HP) capacity, in which case it must be used within the values stipulated in the output torque column.



MOTOR			50Hz			60Hz			TRANSCYKO MODEL	Dimension page	
KW	HP	SYMBOL	Output Torque kgf·m / in·lbs	Allowable Output Shaft Overhung load kgf / lbs	S.F.	Output Torque kgf·m / in·lbs	Allowable Output Shaft Overhung load kgf / lbs	S.F.		H	V
3.7	5	5	1440/124992	14700/32340	<1.0	1440/124992	14700/32340	<1.0	5-622/13-1003	94	150
			1825/158410	18000/39600	<1.0	1691/146779	18000/39600	1.08	5-623/16-1003	96	152
			2019/176117	21000/46200	1.16	1691/146779	21000/46200	1.39	5-624/16-1003	98	154
			2029/176117	26000/57200	1.50	1691/146779	26000/57200	1.80	5-625/17-1003	100	156
5.5	7.5	8	2350/203980	21000/46200	<1.0	2350/203980	21000/46200	<1.0	8-624/16-1003	98	154
			3016/261789	26000/57200	1.01	2513/218128	26000/57200	1.21	8-625/17-1003	100	156
			3016/261789	27800/61160	1.37	2513/218128	27800/61160	1.63	8-626/19-1003	102	158
7.5	10	10	3050/264740	26000/57200	<1.0	3050/264760	26000/57200	<1.0	10-625/17-1003	100	156
			4112/356922	27800/61160	1.01	3427/297464	27800/61160	1.20	10-626/19-1003	102	158
			4112/356922	20000/44000	1.49	3427/297464	20000/44000	1.79	10-627/19-1003	103	159
11	15	15	4140/359352	27800/61160	<1.0	4100/355880	27800/61160	<1.0	15-626/19-1003	102	158
			6031/523491	20000/44000	1.02	5026/436257	20000/44000	1.22	15-627/19-1003	103	159
15	20	20	6150/533820	20000/44000	<1.0	6140/532952	20000/44000	<1.0	20-627/19-1003	103	159

Ratio	Frequency	Motor Input Speed	Reducer Output Speed
1247 (43x29)	50 Hz	1500 R.P.M.	1.2 R.P.M.
	60 Hz	1800 R.P.M.	1.4 R.P.M.

MOTOR			50Hz			60Hz			TRANSCYKO MODEL	Dimension page	
KW	HP	SYMBOL	Output Torque kgf·m / in·lbs	Allowable Output Shaft Overhung load kgf / lbs	S.F.	Output Torque kgf·m / in·lbs	Allowable Output Shaft Overhung load kgf / lbs	S.F.		H	V
0.2	1/4	02	77.0/6684	1365/2003	<1.0	77.0/6684	1365/3003	<1.0	02-613/08-1247	74	130
			103/8940	1500/3300	<1.0	103/8940	1500/3300	<1.0	02-614/08-1247	77	133
			136/11850	2050/4510	1.34	114/9895	2050/4510	1.61	02-616/09-1247	80	136
0.4	1/2	05	183/15884	2050/4510	<1.0	183/15884	2050/4510	<1.0	05-616/09-1247	80	136
			278/24130	2900/6380	<1.0	227/19740	2900/6380	1.22	05-617/09-1247	83	139
			273/23696	4000/8800	1.50	227/19740	4000/8800	1.80	05-618/10-1247	86	142
0.75	1	1	278/24130	2900/6380	<1.0	278/24130	2900/6380	<1.0	1-617/09-1247	83	139
			410/35588	4000/8800	<1.0	410/35588	4000/8800	<1.0	1-618/10-1247	86	142
			511/44355	5400/11880	1.43	426/36977	5400/11880	1.71	1-619/11-1247	88	144
1.5	2	2	730/83364	5400/11880	<1.0	730/83364	5400/11880	<1.0	2-619/11-1247	88	144
			840/72912	8000/17600	<1.0	810/70308	5400/17600	<1.0	2-620/11-1247	90	146
			1022/88710	8800/19360	1.10	852/73954	8000/19360	1.34	2-621/13-1247	92	148
			1022/88710	14700/32340	1.39	852/73954	14700/32340	1.69	2-622/13-1247	94	150
2.2	3	3	1130/98084	8800/19360	<1.0	1140/98952	8800/19360	<1.0	3-621/13-1247	92	148
			1420/123256	14700/32340	<1.0	1250/108500	14700/32340	1.15	3-622/13-1247	94	150
			1500/130200	18000/39600	1.22	1250/108500	18000/39600	1.45	3-623/16-1247	96	152
			1500/130200	21000/46200	1.57	1250/108500	21000/46200	1.88	3-624/16-1247	98	154
3.7	5	5	1420/123256	14700/32340	<1.0	1440/124992	14700/32340	<1.0	5-622/13-1247	94	150
			1825/158410	18000/39600	<1.0	1820/157976	18000/39600	<1.0	5-623/16-1247	96	152
			2350/203980	21000/46200	<1.0	2102/182454	21000/46200	1.12	5-624/16-1247	98	154
			2522/218910	26000/57200	1.21	2102/182454	26000/57200	1.45	5-625/17-1247	100	156
5.5	7.5	8	2350/203980	21000/46200	<1.0	2350/203980	21000/46200	<1.0	8-624/16-1247	98	154
			3050/264740	26000/57200	<1.0	3050/264740	26000/57200	<1.0	8-625/17-1247	100	156
			3124/271163	27800/61160	1.10	3124/271163	27800/61160	1.31	8-626/19-1247	102	158
			3124/271163	20000/44000	1.64	3124/271163	20000/44000	1.97	8-627/19-1247	103	159
7.5	10	10	4140/359352	27800/61160	<1.0	4100/355880	27800/61160	<1.0	10-626/19-1247	102	158
			5113/443808	20000/44000	1.20	4260/369768	20000/44000	1.44	10-627/19-1247	103	159
11	15	15	6150/533820	20000/44000	<1.0	6150/533820	20000/44000	<1.0	15-627/19-1247	103	159
15	20	20	6150/533820	20000/44000	<1.0	6150/533820	20000/44000	<1.0	20-627/19-1247	103	159

\*When S.F. marked as < 1, overload may occur if the motor is loaded to its full KW (HP) capacity, in which case it must be used within the values stipulated in the output torque column.



Ratio	Frequency	Motor Input Speed	Reducer Output Speed
1479 (87x17)	50 Hz	1500 R.P.M.	1.0 R.P.M.
	60 Hz	1800 R.P.M.	1.2 R.P.M.

0.2	1/4	02	77.0/6684	1365/3003	<1.0	77.0/6684	1365/3003	<1.0	02-613/08-1479	74	130
			103/8940	1500/3300	<1.0	103/8940	1500/3300	<1.0	02-614/08-1479	77	133
			162/14062	2050/4510	1.13	135/11718	2050/4510	1.36	02-616/19-1479	80	136
			162/14062	2900/6380	1.72	135/11718	2900/6380	2.05	02-617/09-1479	83	139
										136	
										139	
										142	
0.75	1	1	410/35588	4000/8800	<1.0	410/35588	4000/8800	<1.0	1-618/10-1479	86	142
			606/52601	5400/11880	1.20	505/43834	5400/11880	1.44	1-619/11-1479	88	144
										144	
										148	
										150	
2.2	3	3	1420/123256	14700/32340	<1.0	1280/11104	14700/32340	<1.0	3-622/13-1479	94	150
			1640/142352	18000/39600	<1.0	1482/128638	18000/39600	1.09	3-623/16-1479	96	152
			1779/154417	21000/46200	1.16	1482/128638	21000/46200	1.38	3-624/16-1499	98	154
										152	
										154	
										156	
5.5	7.5	8	2695/233926	26000/57200	<1.0	2750/238700	26000/57200	<1.0	8-625/17-1479	100	156
			3650/316820	27800/61160	<1.0	3692/320466	27800/61160	<1.0	8-626/19-1479	102	158
			4447/386000	20000/44000	1.38	3706/321681	20000/44000	1.66	8-627/19-1479	103	159
										159	
11	15	15	6150/536355	20000/44000	<1.0	6150/533820	20000/44000	<1.0	15-627/19-1479	103	159

Ratio	Frequency	Motor Input Speed	Reducer Output Speed
1849 (43x43)	50 Hz	1500 R.P.M.	0.81 R.P.M.
	60 Hz	1800 R.P.M.	0.97 R.P.M.

0.2	1/4	02	77.0/6684	1365/3003	<1.0	77.0/6684	1365/3003	<1.0	02-613/08-1849	74	130
			103/8940	1500/3300	<1.0	103/8940	1500/3300	<1.0	02-614/08-1849	77	133
			202/17534	2900/6380	1.38	168/14582	2900/6380	1.65	02-617/09-1849	83	139
										136	
										139	
										142	
0.75	1	1	410/35588	4000/8800	<1.0	410/35588	4000/8800	<1.0	1-618/10-1849	86	142
			730/63364	5400/11880	<1.0	632/54858	5400/11880	1.16	1-619/11-1849	88	144
			758/66794	8000/17600	1.07	632/54858	8000/17600	1.28	1-620/11-1849	90	146
										146	
										148	
										150	
2.2	3	3	1440/124992	14700/32340	<1.0	1440/124992	14700/32340	<1.0	3-622/13-1849	94	150
			1825/158410	18000/39600	<1.0	1820/157976	18000/39600	<1.0	3-623/16-1849	96	152
			2224/193043	21000/46200	1.05	1853/160840	21000/46200	1.27	3-624/16-1849	98	154
										154	
										156	
5.5	7.5	8	4140/359352	27800/61160	<1.0	4100/355880	27800/61160	<1.0	8-626/19-1849	102	158
			5559/482521	20000/44000	1.11	4633/402144	20000/44000	1.33	8-627/19-1849	103	159
										159	

\*When S.F. marked as < 1, overload may occur if the motor is loaded to its full KW (HP) capacity, in which case it must be used within the values stipulated in the output torque column.

Ratio	Frequency	Motor Input Speed	Reducer Output Speed
2065 (59x35)	50 Hz	1500 R.P.M.	0.73 R.P.M.
	60 Hz	1800 R.P.M.	0.87 R.P.M.

MOTOR			50Hz			60Hz			TRANSCYKO MODEL	Dimension page	
KW	HP	SYMBOL	Output Torque kgf·m / in·lbs	Allowable Output Shaft Overhung load kgf / lbs	S.F.	Output Torque kgf·m / in·lbs	Allowable Output Shaft Overhung load kgf / lbs	S.F.		H	V
0.2	1/4	02	77.0/6684	1365/3003	<1.0	77.0/6684	1365/3003	<1.0	02-613/08-2065	74	130
			103/8940	1500/3300	<1.0	102/8854	1500/3300	<1.0	02-614/08-2065	77	133
			183/15884	2050/4210	<1.0	183/15884	2050/4510	<1.0	02-616/09-2065	80	136
			226/19617	2900/6380	1.23	188/16318	2900/6380	1.48	02-617/09-2065	83	139
0.4	1/2	05	183/15884	2050/4510	<1.0	183/15884	2050/4510	<1.0	05-616/09-2065	80	136
			278/24130	2900/6380	<1.0	278/24130	2900/6380	<1.0	05-617/09-2065	83	139
			410/35588	4000/8800	<1.0	325/28242	4000/8800	1.09	05-618/10-2065	86	142
0.75	1	1	410/35588	4000/8800	<1.0	410/35588	4000/8800	<1.0	1-618/10-2065	86	142
			730/63364	5400/11880	<1.0	706/61281	5400/11880	1.04	1-619/11-2065	90	144
1.5	2	2	810/70308	8000/17600	<1.0	795/69006	8000/17600	<1.0	2-620/11-2065	90	146
			1140/98952	8800/19360	<1.0	1140/98952	8800/19360	<1.0	2-621/13-2065	92	148
			1440/124992	14700/32340	<1.0	1411/122475	14700/32340	1.02	2-622/13-2065	94	150
2.2	3	3	1440/124992	14700/32340	<1.0	1440/124992	14700/32340	<1.0	3-622/13-2065	94	150
			1825/158410	18000/39600	<1.0	1820/157976	18000/39600	<1.0	3-623/16-2065	96	152
			2350/203980	21000/46200	<1.0	2070/179676	21000/46200	1.14	3-624/16-2065	98	154
3.7	5	5	2350/203980	21000/46200	<1.0	2350/203980	21000/46200	<1.0	5-624/16-2065	98	154
			3050/264740	26000/57200	<1.0	3050/264740	26000/57200	<1.0	5-625/17-2065	100	156
5.5	7.5	8	4140/359352	27800/61160	<1.0	4100/355880	27800/61160	<1.0	8-626/19-2065	102	158
			6150/533820	20000/44000	<1.0	5174/449103	20000/44000	1.19	8-627/19-2065	103	159
7.5	10	10	6150/533820	20000/44000	<1.0	6150/533820	20000/44000	<1.0	10-627/19-2065	103	159

Ratio	Frequency	Motor Input Speed	Reducer Output Speed
2537 (59x43)	50 Hz	1500 R.P.M.	0.59 R.P.M.
	60 Hz	1800 R.P.M.	0.71 R.P.M.

MOTOR			50Hz			60Hz			TRANSCYKO MODEL	Dimension page	
KW	HP	SYMBOL	Output Torque kgf·m / in·lbs	Allowable Output Shaft Overhung load kgf / lbs	S.F.	Output Torque kgf·m / in·lbs	Allowable Output Shaft Overhung load kgf / lbs	S.F.		H	V
0.2	1/4	02	77.0/6684	1365/3003	<1.0	77.0/6735	1365/3003	<1.0	02-613/08-2537	74	130
			103/8940	1500/3300	<1.0	103/8951	1500/3300	<1.0	02-614/08-2537	77	133
			183/15884	2050/4510	<1.0	183/15990	2050/4510	<1.0	02-616/09-2537	80	136
			278/24130	2900/6380	<1.0	231/20422	2900/6380	1.20	02-617/09-2537	83	139
0.4	1/2	05	278/24130	2900/6380	<1.0	278/23898	2900/6380	<1.0	05-617/09-2537	83	149
			410/35588	4000/8800	<1.0	410/35629	4000/8800	<1.0	05-618/10-2537	86	142
0.75	1	1	410/35588	4000/8800	<1.0	410/39105	4000/8800	<1.0	1-618/10-2537	86	142
			730/63364	5400/11880	<1.0	730/63872	5400/11880	<1.0	1-619/11-2537	88	144
			810/70308	8000/17600	<1.0	730/68825	8000/17600	<1.0	1-620/11-2537	90	146
1.5	2	2	810/70308	8000/17600	<1.0	785/73865	8000/17600	<1.0	2-620/11-2537	90	146
			1140/98952	8800/19360	<1.0	1140/99500	8800/19360	<1.0	2-621/13-2537	92	148
			1440/124992	14700/32340	<1.0	1440/125136	14700/32340	<1.0	2-622/13-2537	94	150
2.2	3	3	1825/158410	18000/39600	<1.0	1820/157976	18000/39600	<1.0	3-623/16-2537	96	152
			2350/203980	21000/46200	<1.0	2350/203980	21000/46200	<1.0	3-624/16-2537	98	154
3.7	5	5	3050/364740	26000/57200	<1.0	3050/264740	26000/57200	<1.0	5-625/17-2537	100	156
5.5	7.5	8	4140/359352	27800/61160	<1.0	4100/355880	27800/61160	<1.0	8-626/19-2537	102	158
			6150/533820	20000/44000	<1.0	6150/533820	20000/44000	<1.0	8-627/19-2537	103	159
7.5	10	10	6150/533820	20000/44000	<1.0	6150/533820	20000/44000	<1.0	10-627/19-2537	103	159

\*When S.F. marked as < 1, overload may occur if the motor is loaded to its full KW (HP) capacity, in which case it must be used within the values stipulated in the output torque column.



Ratio	Frequency	Motor Input Speed	Reducer Output Speed
3045 (87x35)	50 Hz	1500 R.P.M.	0.49 R.P.M.
	60 Hz	1800 R.P.M.	0.59 R.P.M.

MOTOR			50Hz			60Hz			TRANSCYKO MODEL	Dimension page	
KW	HP	SYMBOL	Output Torque kgf·m / in·lbs	Allowable Output Shaft Overhung load kgf / lbs	S.F.	Output Torque kgf·m / in·lbs	Allowable Output Shaft Overhung load kgf / lbs	S.F.		H	V
0.2	1/4	02	77.0/6684	1365/3003	<1.0	77.0/6684	1365/3003	<1.0	02-613/08-3045	74	130
			103/8940	1500/3300	<1.0	103/8940	1500/3300	<1.0	02-614/08-3045	77	133
			183/8940	2050/4510	<1.0	183/15884	2050/4510	<1.0	02-616/09-3045	80	136
			278/24130	2900/6380	<1.0	277/24044	2900/6380	1.00	02-617/09-3045	83	139
0.4	1/2	05	278/24130	2900/6380	<1.0	278/24130	2900/6380	<1.0	05-617/09-3045	83	139
			410/35588	4000/8800	<1.0	410/35588	4000/8800	<1.0	05-618/10-3045	86	142
0.75	1	1	730/63364	5400/11880	<1.0	730/63364	5400/11880	<1.0	1-619/11-3045	88	144
1.5	2	2	955/82894	8800/19360	<1.0	950/82462	8800/19360	<1.0	2-621/13-3045	92	148
			1250/108500	14700/32340	<1.0	1275/110670	14700/32340	<1.0	2-622/13-3045	94	150
2.2	3	3	1620/140616	18000/39600	<1.0	1600/138880	18000/39600	<1.0	3-623/16-3045	96	152
			2050/177940	21000/46200	<1.0	2050/177940	21000/46200	<1.0	3-624/16-3045	98	154
3.7	5	5	2650/227700	26000/57200	<1.0	2650/230020	26000/57200	<1.0	5-625/17-3045	100	156
5.5	7.5	8	3540/307272	27800/61160	<1.0	3520/305536	27800/61160	<1.0	8-626/19-3045	102	158
			6150/533820	20000/40000	<1.0	6150/533820	20000/44000	<1.0	8-627/19-3045	103	159
7.5	10	10	6150/533820	20000/40000	<1.0	6150/533820	20000/44000	<1.0	10-627/19-3045	103	159

Ratio	Frequency	Motor Input Speed	Reducer Output Speed
3481 (59x59)	50 Hz	1500 R.P.M.	0.43 R.P.M.
	60 Hz	1800 R.P.M.	0.52 R.P.M.

MOTOR			50Hz			60Hz			TRANSCYKO MODEL	Dimension page	
KW	HP	SYMBOL	Output Torque kgf·m / in·lbs	Allowable Output Shaft Overhung load kgf / lbs	S.F.	Output Torque kgf·m / in·lbs	Allowable Output Shaft Overhung load kgf / lbs	S.F.		H	V
0.2	1/4	02	77.0/6684	1365/3003	<1.0	77.0/6684	1365/3003	<1.0	02-613/08-3481	74	130
			103/8940	1500/3300	<1.0	103/8940	1500/3300	<1.0	02-614/08-3481	77	133
			183/15884	2050/4510	<1.0	183/15884	2050/4510	<1.0	02-616/09-3481	80	136
			278/24130	2900/6380	<1.0	278/24130	2900/6380	<1.0	02-617/09-3481	83	139
0.4	1/2	05	278/24130	2900/6380	<1.0	278/24130	2900/6380	<1.0	05-617/09-3481	83	139
			410/35588	4000/8800	<1.0	410/35588	4000/8800	<1.0	05-618/10-3481	86	142
0.75	1	1	730/63364	5400/11880	<1.0	730/63364	5400/11880	<1.0	1-619/11-3481	88	144
1.5	2	2	860/74648	8000/17600	<1.0	860/74648	8000/17600	<1.0	1-620/11-3481	90	146
			1140/98952	8800/19360	<1.0	1140/98952	8800/19360	<1.0	2-621/13-3481	92	148
2.2	3	3	1440/124992	14700/32340	<1.0	1440/124992	14700/32340	<1.0	2-622/13-3481	94	150
			1810/157108	18000/39600	<1.0	1810/157108	18000/39600	<1.0	3-623/16-3481	96	152
3.7	5	5	2350/203980	21000/46200	<1.0	2350/203980	21000/46200	<1.0	3-624/16-3481	98	154
			3050/264740	26000/57200	<1.0	3050/264740	26000/57200	<1.0	5-625/17-3481	100	156
5.5	8	8	4100/355880	27800/61160	<1.0	4100/355880	27800/61160	<1.0	8-626/19-3481	102	158
			6150/533820	20000/44000	<1.0	6150/533820	20000/44000	<1.0	8-627/19-3481	103	159
7.5	10	10	6150/533820	20000/44000	<1.0	6150/533820	20000/44000	<1.0	10-627/19-3481	103	159

Ratio	Frequency	Motor Input Speed	Reducer Output Speed
4437 (87x51)	50 Hz	1500 R.P.M.	0.34 R.P.M.
	60 Hz	1800 R.P.M.	0.41 R.P.M.

MOTOR			50Hz			60Hz			TRANSCYKO MODEL	Dimension page	
KW	HP	SYMBOL	Output Torque kgf·m / in·lbs	Allowable Output Shaft Overhung load kgf / lbs	S.F.	Output Torque kgf·m / in·lbs	Allowable Output Shaft Overhung load kgf / lbs	S.F.		H	V
0.2	1/4	02	77.0/6684	1365/3003	<1.0	77.0/6684	1365/3003	<1.0	02-613/08-4437	74	130
			103/8940	1500/3300	<1.0	103/8940	1500/3300	<1.0	02-614/08-4437	77	133
			183/15884	2050/4510	<1.0	183/15884	2050/4510	<1.0	02-616/09-4437	80	136
			278/24130	2900/6380	<1.0	278/24130	2900/3680	<1.0	02-617/09-4437	83	139
0.4	1/2	05	410/35588	4000/8800	<1.0	410/35588	4000/8800	<1.0	05-618/10-4437	86	142

\*When S.F. marked as < 1, overload may occur if the motor is loaded to its full KW (HP) capacity, in which case it must be used within the values stipulated in the output torque column.



Ratio	Frequency	Motor Input Speed	Reducer Output Speed
4437 (87x51)	50 Hz	1500 R.P.M.	0.34 R.P.M.
	60 Hz	1800 R.P.M.	0.41 R.P.M.

MOTOR			50Hz			60Hz			TRANSCYKO MODEL	Dimension page	
KW	HP	SYMBOL	Output Torque kgf·m / in·lbs	Allowable Output Shaft Overhung load kgf / lbs	S.F.	Output Torque kgf·m / in·lbs	Allowable Output Shaft Overhung load kgf / lbs	S.F.		H	V
0.75	1	1	730/63364	5400/11880	<1.0	730/63364	5400/11880	<1.0	1-619/11-4437	88	144
1.5	2	2	950/82460	8800/19360	<1.0	950/82460	8800/19360	<1.0	2-621/13-4437	92	148
			1275/110670	14700/32340	<1.0	1275/110670	14700/32340	<1.0	2-622/13-4437	94	150
2.2	3	3	1600/138880	18000/39600	<1.0	1600/138880	18000/39600	<1.0	3-623/16-4437	96	152
			2050/177940	21000/46200	<1.0	2050/177940	21000/46200	<1.0	3-624/16-4437	98	154
3.7	5	5	2650/230020	26000/57200	<1.0	2650/230020	26000/57200	<1.0	5-625/17-4437	100	156
5.5	7.5	8	3520/305536	27800/61160	<1.0	3520/305536	27800/61160	<1.0	8-626/19-4437	102	158
			6150/533820	20000/44000	<1.0	6150/533820	20000/44000	<1.0	8-627/19-4437	103	159
7.5	10	10	6150/533820	20000/44000	<1.0	6150/533820	20000/44000	<1.0	10-627/19-4437	103	159

Ratio	Frequency	Motor Input Speed	Reducer Output Speed
5133 (87x59)	50 Hz	1500 R.P.M.	0.29 R.P.M.
	60 Hz	1800 R.P.M.	0.35 R.P.M.

MOTOR			50Hz			60Hz			TRANSCYKO MODEL	Dimension page	
KW	HP	SYMBOL	Output Torque kgf·m / in·lbs	Allowable Output Shaft Overhung load kgf / lbs	S.F.	Output Torque kgf·m / in·lbs	Allowable Output Shaft Overhung load kgf / lbs	S.F.		H	V
0.2	1/4	02	77.0/6684	1356/3003	<1.0	77.0/6684	1356/3003	<1.0	02-613/08-5133	74	130
			103/8940	1500/3300	<1.0	103/8940	1500/3300	<1.0	02-614/08-5133	77	133
			183/15884	2050/4510	<1.0	183/15884	2050/4510	<1.0	02-616/09-5133	80	136
			278/24130	2900/6380	<1.0	278/24130	2900/6380	<1.0	02-617/09-5133	83	139
0.4	1/2	05	410/35588	4000/8800	<1.0	410/35588	4000/8800	<1.0	05-618/10-5133	86	142
0.75	1	1	730/63364	5400/11880	<1.0	730/63364	5400/11880	<1.0	1-619/11-5133	88	144
			860/74648	8000/17600	<1.0	860/74648	8000/17600	<1.0	1-620/11-5133	90	146
1.5	2	2	1140/98952	8800/19360	<1.0	1140/98952	8800/19360	<1.0	2-621/13-5133	92	148
			1440/124992	14700/32340	<1.0	1440/124992	14700/32340	<1.0	2-622/13-5133	94	150
2.2	3	3	1810/157108	18000/39600	<1.0	1810/157108	18000/39600	<1.0	3-623/16-5133	96	152
			2350/203980	21000/46200	<1.0	2350/203980	21000/46200	<1.0	3-624/16-5133	98	154
3.7	5	5	3050/264740	26000/57200	<1.0	3050/264740	26000/57200	<1.0	5-625/17-5133	100	156
5.5	7.5	8	4100/355880	27800/61160	<1.0	4100/355880	27800/61160	<1.0	8-626/19-5133	102	158
			6150/533820	20000/44000	<1.0	6150/533820	20000/44000	<1.0	8-627/19-5133	103	159
7.5	10	10	6150/533820	20000/44000	<1.0	6150/533820	20000/44000	<1.0	10-627/19-5133	103	159

Ratio	Frequency	Motor Input Speed	Reducer Output Speed
6177 (87x71)	50 Hz	1500 R.P.M.	0.24 R.P.M.
	60 Hz	1800 R.P.M.	0.29 R.P.M.

MOTOR			50Hz			60Hz			TRANSCYKO MODEL	Dimension page	
KW	HP	SYMBOL	Output Torque kgf·m / in·lbs	Allowable Output Shaft Overhung load kgf / lbs	S.F.	Output Torque kgf·m / in·lbs	Allowable Output Shaft Overhung load kgf / lbs	S.F.		H	V
0.2	1/4	02	77.0/6684	1365/3003	<1.0	77.0/6684	1365/3003	<1.0	02-613/09-6177	75	131
			103/8940	1500/3300	<1.0	103/8940	1500/3300	<1.0	02-614/09-6177	78	134
			183/15884	2050/4510	<1.0	183/15884	2050/4510	<1.0	02-616/09-6177	80	136
			278/24130	2900/6380	<1.0	278/24130	2900/6380	<1.0	02-617/09-6177	183	139
0.4	1/2	05	410/35588	4000/8800	<1.0	410/35588	4000/8800	<1.0	05-618/10-6177	86	142
0.75	1	1	730/63364	5400/11880	<1.0	730/63364	5400/11880	<1.0	1-619/11-6177	88	144
			950/82460	8800/19360	<1.0	950/82460	8800/19360	<1.0	2-621/13-6177	92	148
1.5	2	2	1275/100670	14700/32340	<1.0	1275/100670	14700/32340	<1.0	2-622/13-6177	94	150
			1600/138880	18000/39600	<1.0	1600/138880	18000/39600	<1.0	3-623/16-6177	96	152
2.2	3	3	2050/177940	21000/46200	<1.0	2050/177940	21000/46200	<1.0	3-624/16-6177	98	154
			2650/230020	26000/57200	<1.0	2650/230020	26000/57200	<1.0	5-625/17-6177	100	156
5.5	7.5	8	3520/305536	27800/61160	<1.0	3520/305536	27800/61160	<1.0	8-626/19-6177	102	158
			6150/533820	20000/44000	<1.0	6150/533820	20000/44000	<1.0	8-627/19-6177	103	159
7.5	10	10	6150/533820	20000/44000	<1.0	6150/533820	20000/44000	<1.0	10-627/19-6177	103	159

\*When S.F. marked as < 1, overload may occur if the motor is loaded to its full KW (HP) capacity, in which case it must be used within the values stipulated in the output torque column.



Ratio	Frequency	Motor Input Speed	Reducer Output Speed
7569 (87x87)	50 Hz	1500 R.P.M.	0.20 R.P.M.
	60 Hz	1800 R.P.M.	0.24 R.P.M.

MOTOR			50Hz			60Hz			TRANSCYKO MODEL	Dimension page	
KW	HP	SYMBOL	Output Torque kgf·m / in·lbs	Allowable Output Shaft Overhung load kgf / lbs	S.F.	Output Torque kgf·m / in·lbs	Allowable Output Shaft Overhung load kgf / lbs	S.F.		H	V
0.2	1/4	02	77.0/6684	1365/3003	<1.0	77.0/6684	1365/3003	<1.0	02-613/09-7569	75	131
			103/8940	1500/3300	<1.0	103/8940	1500/3300	<1.0	02-614/09-7569	78	134
			183/15884	2050/4510	<1.0	183/15884	2050/4510	<1.0	02-616/09-7569	80	136
			278/24130	2900/6380	<1.0	278/24130	2900/6380	<1.0	02-617/09-7569	83	139
0.4	1/2	05	410/35588	4000/8800	<1.0	410/35588	4000/8800	<1.0	05-618/10-7569	86	142
0.75	1	1	730/63364	5400/11880	<1.0	730/63364	5400/11880	<1.0	1-619/11-7569	88	144
1.5	2	2	950/82460	8800/19360	<1.0	950/82460	8800/19360	<1.0	2-621/13-7569	92	148
			1275/110670	14700/32340	<1.0	1275/110670	14700/32340	<1.0	2-622/13-7569	94	150
2.2	3	3	1600/138880	18000/39600	<1.0	1600/138880	18000/39600	<1.0	3-623/16-7569	96	152
			2050/177940	21000/46200	<1.0	2050/177940	21000/46200	<1.0	3-624/16-7569	98	154
3.7	5	5	2650/230020	26000/57200	<1.0	2650/230020	26000/57200	<1.0	5-625/17-7569	100	156
5.5	7.5	8	3500/303800	27800/61160	<1.0	3500/303800	27800/61160	<1.0	8-626/19-7569	102	158
			6150/533820	20000/44000	<1.0	6150/533820	20000/44000	<1.0	8-627/19-7569	103	159
7.5	10	10	6150/533820	20000/44000	<1.0	6150/533820	20000/44000	<1.0	10-627/19-7569	103	159

\*When S.F. marked as <1, overload may occur if the motor is loaded to its full KW (HP) capacity, in which case it must be used within the values stipulated in the output torque column.

# SELECTION TABLE WITH 6 POLE MOTOR

Ratio	Frequency	Motor Input Speed	Reducer Output Speed
11	50 Hz	1000 R.P.M.	91 R.P.M.
	60 Hz	1200 R.P.M.	109 R.P.M.

MOTOR			50Hz			60Hz			TRANSCYKO MODEL	Dimension page	
KW	HP	SYMBOL	Output Torque kgf·m / in·lbs	Allowable Output Shaft Overhung load kgf / lbs	S.F.	Output Torque kgf·m / in·lbs	Allowable Output Shaft Overhung load kgf / lbs	S.F.		H	V
55	75	75/6	544/47219	6450/14190	1.68	454/40275	6100/13420	1.69	75/6-623-11	64	120
75	100	100/6	742/64406	6450/14190	1.24	619/53729	6100/13420	1.24	100/6-623-11	64	120
				7200/15840	1.60		6800/14960	1.57	100/6-624-11	65	121
				8850/19470	1.93		8350/18370	1.93	100/6-625-11	66	122
90	125	125/6	891/77339	6450/14190	1.05	742/64406	6100/13420	1.05	125/6-623-11	64	120
				7200/15840	1.33		6800/14960	1.33	125/6-624-11	65	121
				8850/19470	1.61		8350/18370	1.58	125/6-625-11	66	122
				10750/23650	1.85		10250/22550	1.86	125/6-626-11	67	123
110	150	150/6	1089/94525	7200/15840	1.03	908/78814	6800/14960	1.03	150/6-624-11	65	121
				8850/19470	1.27		8350/18370	1.27	150/6-625-11	66	122
				10750/23650	1.52		10250/22550	1.52	150/6-626-11	67	123
132	175	175/6	1307/113448	8850/19470	1.06	1089/94525	8350/18370	1.06	175/6-625-11	66	122
				10750/23650	1.28		10250/22550	1.28	175/6-626-11	67	123

Ratio	Frequency	Motor Input Speed	Reducer Output Speed
15	50 Hz	1000 R.P.M.	67 R.P.M.
	60 Hz	1200 R.P.M.	80 R.P.M.

MOTOR			50Hz			60Hz			TRANSCYKO MODEL	Dimension page	
KW	HP	SYMBOL	Output Torque kgf·m / in·lbs	Allowable Output Shaft Overhung load kgf / lbs	S.F.	Output Torque kgf·m / in·lbs	Allowable Output Shaft Overhung load kgf / lbs	S.F.		H	V
37	50	50/6	500/43400	7095/15609	2.50	416/36109	6720/14784	2.51	50/6-623-15	64	120
45	60	60/6	608/52774	7095/15609	2.07	506/43921	6720/14784	2.08	60/6-623-15	64	120
55	75	75/6	745/64406	7095/15609	1.69	619/53729	6720/14784	1.68	75/6-623-15	64	120
75	100	100/6	1012/87842	7095/15609	1.24	844/73259	6720/14784	1.24	100/6-623-15	64	120
				7905/17391	1.51		7500/16500	1.51	100/6-624-15	65	121
				9600/21120	1.86		9145/20119	1.86	100/6-625-15	66	122
90	125	125/6	1215/105462	7095/15609	1.05	1012/87842	6720/14784	1.03	125/6-623-15	64	120
				7905/17391	1.26		7500/16500	1.26	125/6-624-15	65	121
				9600/21120	1.53		9145/20119	1.55	125/6-625-15	66	122
				11900/26180	1.87		11250/24750	1.86	125/6-626-15	67	123
110	150	150/6	1485/128898	7905/17391	1.03	1238/107458	7500/16500	1.03	150/6-624-15	65	121
				9600/21120	1.27		9145/20119	1.27	150/6-625-15	66	122
				11900/26180	1.52		11250/24750	1.52	150/6-626-15	67	123
132	175	175/6	1782/154678	9600/21120	1.06	1485/128898	9145/20119	1.06	175/6-625-15	66	122
				11900/26180	1.27		11250/24750	1.27	175/6-626-15	67	123

Ratio	Frequency	Motor Input Speed	Reducer Output Speed
21	50 Hz	1000 R.P.M.	48 R.P.M.
	60 Hz	1200 R.P.M.	57 R.P.M.

MOTOR			50Hz			60Hz			TRANSCYKO MODEL	Dimension page	
KW	HP	SYMBOL	Output Torque kgf·m / in·lbs	Allowable Output Shaft Overhung load kgf / lbs	S.F.	Output Torque kgf·m / in·lbs	Allowable Output Shaft Overhung load kgf / lbs	S.F.		H	V
30	40	40/6	567/49216	7850/17270	2.47	472/40970	7440/16368	2.47	40/6-623-21	64	120
37	50	50/6	699/60673	7850/17270	1.97	583/50604	7440/16368	1.98	50/6-623-21	64	120
45	60	60/5	850/73780	7850/17270	1.61	709/61541	7440/16368	1.62	60/6-623-21	64	120
				8735/19217	2.15		8275/18205	2.16	60/6-624-21	65	121
55	75	75/6	1040/90272	7850/17270	1.31	866/75169	7440/16368	1.35	75/6-623-21	64	120
				8735/19217	1.74		8275/18205	1.74	75/6-624-21	65	121

\*Please select models in the shaded column when a load factor of 1.0 is required as shown on page 8.



MOTOR			50Hz			60Hz			TRANSCYKO MODEL	Dimension page	
KW	HP	SYMBOL	Output Torque kgf·m / in·lbs	Allowable Output Shaft Overhung load kgf / lbs	S.F.	Output Torque kgf·m / in·lbs	Allowable Output Shaft Overhung load kgf / lbs	S.F.		H	V
75	100	100/6	1418/123082	7850/17270	1.01	1181/102511	7440/16368	1.01	100/6-623-21	64	120
				8735/19217	1.27		8275/18205	1.27	100/6-624-21	65	121
				10750/23650	1.52		10150/22330	1.52	100/6-625-21	66	122
				13050/28710	1.88		12350/27170	1.88	100/6-626-21	67	123
90	125	125/6	1701/147647	8735/19217	1.06	1418/123082	8275/18205	1.06	125/6-624-21	65	121
				10750/23650	1.27		10105/22330	1.27	125/6-625-21	66	122
				13050/28710	1.56		12350/27170	1.60	125/6-626-21	67	123
110	150	150/6	2079/180457	10750/23650	1.05	1732/150338	10150/22330	1.05	150/6-625-21	66	122
				13050/28710	1.27		12350/27170	1.28	150/6-626-21	67	123
132	175	175/6	2495/216566	13050/28710	1.06	2079/180457	12350/27170	1.06	175/6-626-21	67	123

Ratio	Frequency	Motor Input Speed	Reducer Output Speed
29	50 Hz	1000 R.P.M.	34 R.P.M.
	60 Hz	1200 R.P.M.	41 R.P.M.

MOTOR			50Hz			60Hz			TRANSCYKO MODEL	Dimension page	
KW	HP	SYMBOL	Output Torque kgf·m / in·lbs	Allowable Output Shaft Overhung load kgf / lbs	S.F.	Output Torque kgf·m / in·lbs	Allowable Output Shaft Overhung load kgf / lbs	S.F.		H	V
30	40	40/6	783/67964	8650/19030	1.87	652/56594	8200/18040	1.87	40/6-623-29	64	120
37	50	50/6	966/83849	8650/19030	1.51	805/69874	8200/18040	1.51	50/6-623-29	64	120
				9650/21230	1.88		9150/20130	1.88	50/6-624-29	65	121
45	60	60/6	1174/101903	8650/19030	1.24	979/84977	8200/18040	1.24	60/6-623-29	64	120
				9650/21230	1.55		9150/20130	1.55	60/6-624-29	65	121
				11850/26070	2.13		11150/24530	2.14	60/6-625-29	66	122
55	75	75/6	1436/123645	8650/19030	1.02	1196/103813	8200/18040	1.02	75/6-623-29	64	120
				9650/21230	1.26		9150/20130	1.26	75/6-624-29	65	121
				11850/26070	1.74		11150/24530	1.74	75/6-625-29	66	122
75	100	100/6	1958/169954	11850/26070	1.27	1631/141571	11150/24530	1.27	100/6-625-29	66	122
				14500/31900	1.79		13500/29700	1.82	100/6-626-29	67	123
90	125	125/6	2349/203893	11850/26070	1.06	1958/169954	11150/24530	1.06	125/6-625-29	66	122
				14500/31900	1.50		13500/29700	1.50	125/6-626-29	67	123
				20000/44000	1.61		20000/44000	1.61	125/6-627-29	190	219
110	150	150/6	2871/249203	14500/31900	1.22	2392/207626	13500/29700	1.24	150/6-626-29	67	123
				20000/44000	1.30		20000/44000	1.30	150/6-627-29	190	219
132	175	175/6	3445/299026	14500/31900	1.02	2871/249203	13500/29700	1.04	175/6-626-29	67	123

Ratio	Frequency	Motor Input Speed	Reducer Output Speed
43	50 Hz	1000 R.P.M.	23 R.P.M.
	60 Hz	1200 R.P.M.	29 R.P.M.

MOTOR			50Hz			60Hz			TRANSCYKO MODEL	Dimension page	
KW	HP	SYMBOL	Output Torque kgf·m / in·lbs	Allowable Output Shaft Overhung load kgf / lbs	S.F.	Output Torque kgf·m / in·lbs	Allowable Output Shaft Overhung load kgf / lbs	S.F.		H	V
18.5	25	25/6	716/62149	9750/21450	2.15	597/51820	9200/20240	2.32	25/6-623-43	64	120
22	30	30/6	851/73867	9750/21450	1.85	710/61628	9200/20240	1.95	30/6-623-43	64	120
30	40	40/6	1161/100775	9750/21450	1.39	968/84022	9200/20240	1.43	40/6-623-43	64	120
				10850/23870	1.84		10350/22770	1.86	40/6-624-43	65	121
37	50	50/6	1432/124298	9750/21450	1.13	1193/103552	9200/20240	1.16	50/6-623-43	64	120
				10850/23870	1.50		10350/22770	1.52	50/6-624-43	65	121
				13250/29150	1.85		12550/27610	1.85	50/6-625-43	66	122
45	60	60/6	1742/151206	10850/23870	1.23	1451/125947	10350/22770	1.25	60/6-624-43	65	121
				13250/29150	1.52		12550/27610	1.54	60/6-625-43	66	122
				16250/35370	2.13		15300/33660	2.13	60/6-626-43	67	123
55	75	75/6	2128/184710	10850/23870	1.02	1774/153983	10350/22770	1.02	75/6-624-43	65	121
				13250/29150	1.23		12550/27610	1.23	75/6-625-43	66	122
				16250/35750	1.74		15300/33660	1.74	75/6-626-43	67	123

\*Please select models in the shaded column when a load factor of 1.0 is required as shown on page 8.



MOTOR			50Hz			60Hz			TRANSCYKO MODEL	Dimension page	
KW	HP	SYMBOL	Output Torque kgf·m / in·lbs	Allowable Output Shaft Overhung load kgf / lbs	S.F.	Output Torque kgf·m / in·lbs	Allowable Output Shaft Overhung load kgf / lbs	S.F.		H	V
75	100	100/6	2902/251894	16250/35750	1.27	2419/209969	15300/33660	1.27	100/6-626-43	67	123
				20000/44000	1.68		20000/44000	1.69	100/6-627-43	190	219
90	125	125/6	3483/302324	16250/35750	1.06	2902/251894	15300/33660	1.08	125/6-626-43	67	123
				20000/44000	1.40		20000/44000	1.42	125/6-627-43	190	219

Ratio	Frequency	Motor Input Speed	Reducer Output Speed
59	50 Hz	1000 R.P.M.	17 R.P.M.
	60 Hz	1200 R.P.M.	20 R.P.M.

MOTOR			50Hz			60Hz			TRANSCYKO MODEL	Dimension page	
KW	HP	SYMBOL	Output Torque kgf·m / in·lbs	Allowable Output Shaft Overhung load kgf / lbs	S.F.	Output Torque kgf·m / in·lbs	Allowable Output Shaft Overhung load kgf / lbs	S.F.		H	V
15	20	20/6	796/69093	10750/23650	1.87	664/57635	10250/22550	1.96	20/6-623-59	64	120
18.5	25	25/6	982/85238	10750/23650	1.60	819/71089	10250/22500	1.60	25/6-623-59	64	120
				11950/26290	2.04		11300/24860	2.05	25/6-624-59	65	121
22	30	30/6	1168/101382	10750/23650	1.30	974/84543	10250/22550	1.32	30/6-623-59	64	120
				11950/26290	1.74		11300/24860	1.75	30/6-624-59	65	121
30	40	40/6	1593/138272	10750/23650	1.00	1328/115270	10250/22550	1.02	40/6-623-59	64	120
				11950/26290	1.29		11300/24860	1.30	40/6-624-59	65	121
				14650/32230	1.86		14000/30800	1.86	40/6-625-59	66	122
37	50	50/6	1965/170562	11950/26290	1.05	1637/142092	11300/24860	1.04	50/6-624-59	65	121
				14650/32320	1.50		14000/30800	1.51	50/6-625-59	66	122
				17850/32970	1.90		16900/37180	1.95	50/6-626-59	67	123
45	60	60/6	2400/208320	14650/32230	1.23	1991/172819	14000/30800	1.24	60/6-625-59	66	122
				17850/39270	1.60		16900/37180	1.60	60/6-626-59	67	123
				20000/44000	2.25		20000/44000	2.35	60/6-627-59	190	219
55	75	75/6	2920/253456	14650/32230	1.01	2434/211271	14000/30800	1.02	75/6-625-59	66	122
				17850/39270	1.30		16900/37180	1.32	75/6-626-59	67	123
				20000/44000	1.80		20000/44000	1.90	75/6-627-59	190	219
75	100	100/6	3982/345638	17850/39270	1.00	3319/288089	16900/37180	1.02	100/6-626-59	67	123
				20000/44000	1.35		20000/44000	1.40	100/6-627-59	190	219

Ratio	Frequency	Motor Input Speed	Reducer Output Speed
87	50 Hz	1000 R.P.M.	11 R.P.M.
	60 Hz	1200 R.P.M.	14 R.P.M.

MOTOR			50Hz			60Hz			TRANSCYKO MODEL	Dimension page	
KW	HP	SYMBOL	Output Torque kgf·m / in·lbs	Allowable Output Shaft Overhung load kgf / lbs	S.F.	Output Torque kgf·m / in·lbs	Allowable Output Shaft Overhung load kgf / lbs	S.F.		H	V
15	20	20/6	1174/101903	12050/26510	1.30	979/84977	11450/25190	1.35	20/6-623-87	64	120
				13450/29590	1.69		12750/28050	1.80	20/6-624-87	65	121
18.5	25	25/6	1448/125685	12050/26590	1.12	1207/104768	11450/25190	1.13	25/6-623-87	64	120
				13450/29590	1.40		12750/28050	1.43	25/6-624-87	65	121
				16450/36198	1.80		15550/34210	1.90	25/6-625-87	66	122
22	30	30/6	1723/149556	13450/29590	1.15	1436/124645	12750/28050	1.20	30/6-624-87	65	121
				16450/36190	1.50		15550/34210	1.60	30/6-625-87	66	122
				20000/44000	1.95		19000/41800	2.05	30/6-626-87	67	123
30	40	40/6	2349/203893	16450/36190	1.11	1958/169954	15550/34210	1.15	40/6-625-87	66	122
				20000/44000	1.48		19000/41800	1.50	40/6-626-87	67	219
				20000/44000	1.65		20000/44000	1.68	40/6-627-87	190	123
37	50	50/6	2897/251460	20000/44000	1.16	2414/209535	19000/41800	1.24	50/6-626-87	67	219
				20000/44000	1.37		20000/44000	1.38	50/6-627-87	190	123
45	60	60/6	3524/305883	20000/44000	1.01	2936/254845	19000/41800	1.02	60/6-626-87	67	219
				20000/44000	1.15		20000/44000	1.16	60/6-627-87	190	

\*Please select models in the shaded  column when a load factor of 1.0 is required as shown on page 8.



# DIMENSION DRAWINGS For Single Reduction, Horizontal TRANSCYKO Gearmotor

THM-607

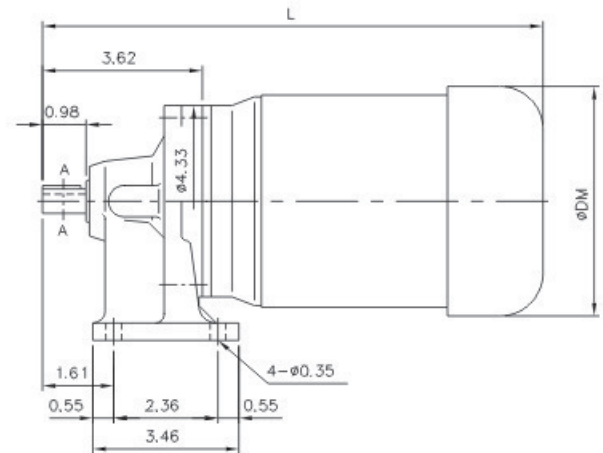
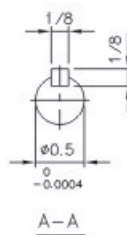
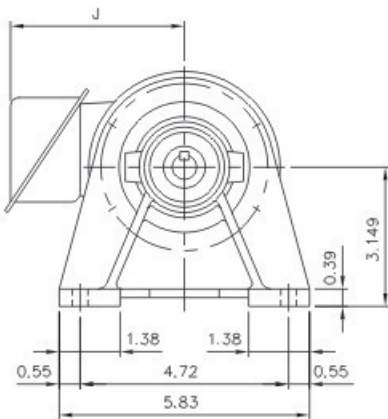
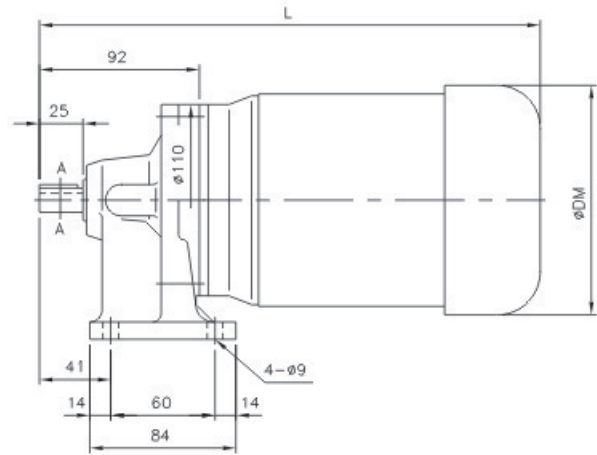
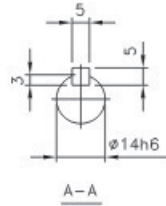
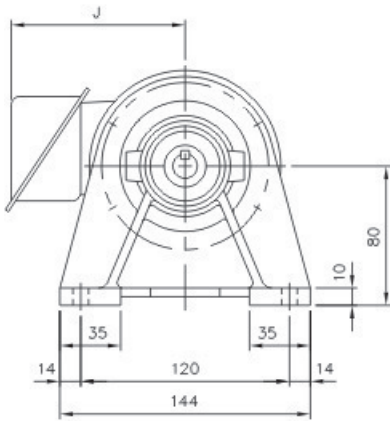

Motor			TRANSCYKO Model No.	Metric ( mm, kg )					Inches ( in.lbs )				
KW	HP	POLE		L	J	DM	H	Weight	L	J	DM	H	Weight
0.2	1/4	4	THM02-607	311	121	144	135	12	12.24	4.76	5.67	5.31	26.4

**THM-608**

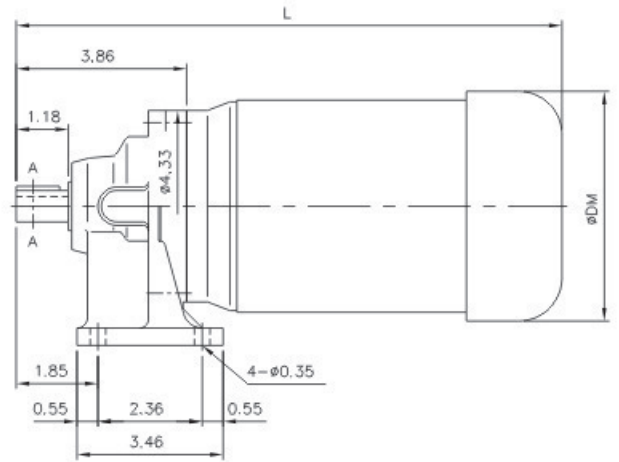
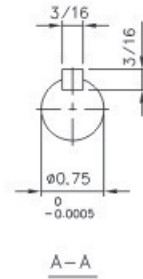
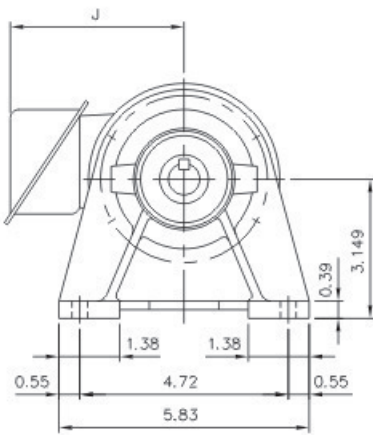
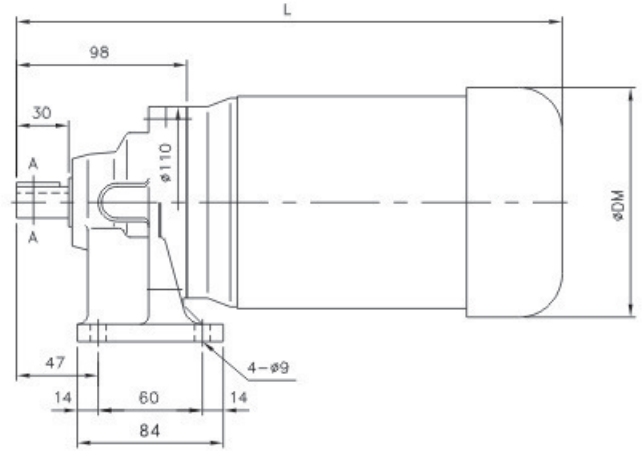
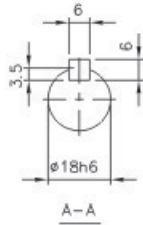
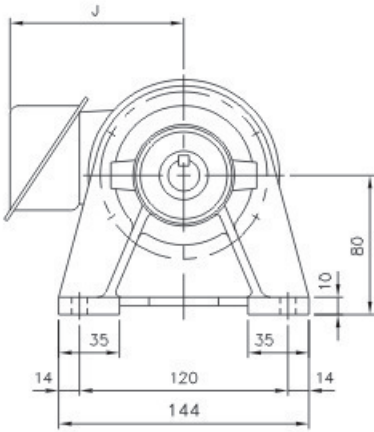

Motor			TRANSCYKO Model No.	Metric ( mm, kg )					Inches ( in.lbs )				
KW	HP	POLE		L	J	DM	H	Weight	L	J	DM	H	Weight
0.2	1/4	4	THM02-608	317	121	144	135	12	12.48	4.45	5.67	5.31	26.4
0.4	1/2	4	THM05-608	388	132	162	135	14	13.31	5.12	6.38	5.31	30.8



# THM-609

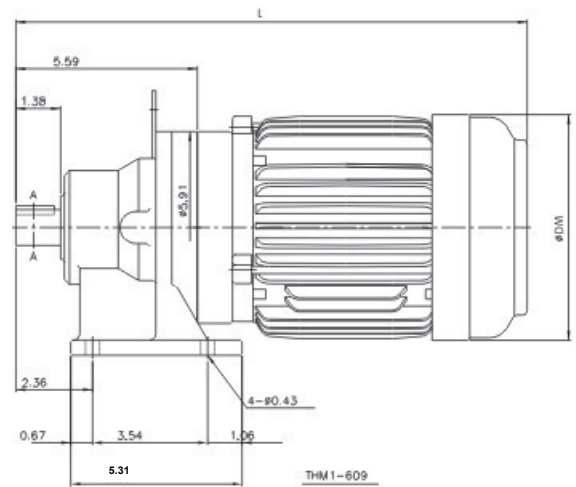
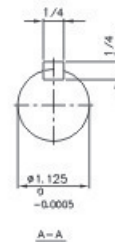
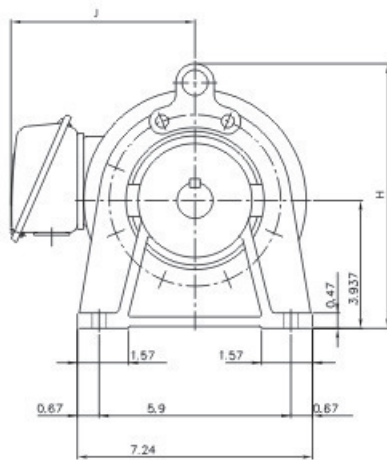
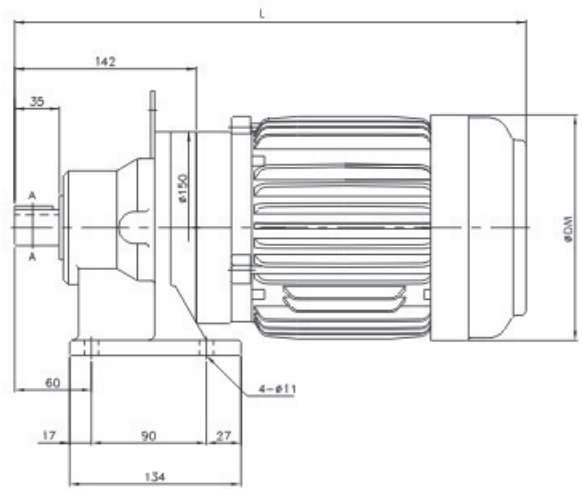
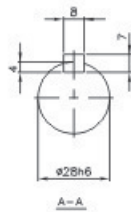
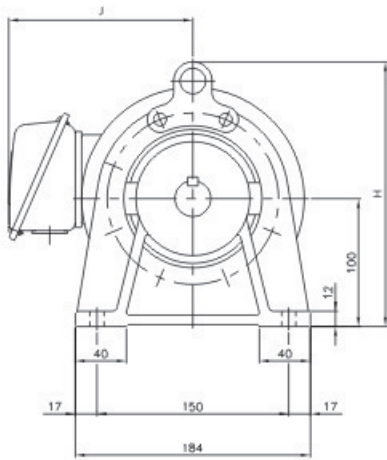

Motor			TRANSCYKO Model No.	Metric ( mm, kg )					Inches ( in.lbs )				
KW	HP	POLE		L	J	DM	H	Weight	L	J	DM	H	Weight
0.2	1/4	4	THM02-609	361	121	144	207	19	14.21	4.76	5.67	8.15	41.8
0.4	1/2	4	THM05-608	392	132	162	207	23	15.04	5.20	6.38	8.15	50.6
0.75	1	4	THM1-609	402	137	177	207	27	15.00	5.39	6.97	8.15	59.4

# THM-610

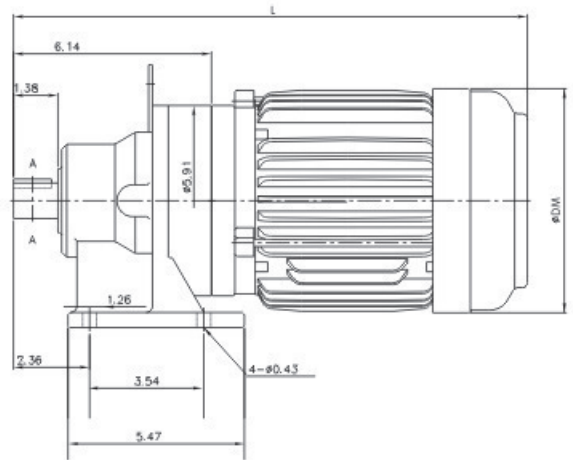
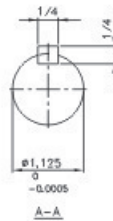
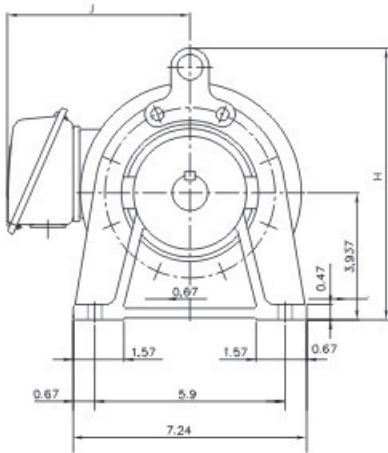
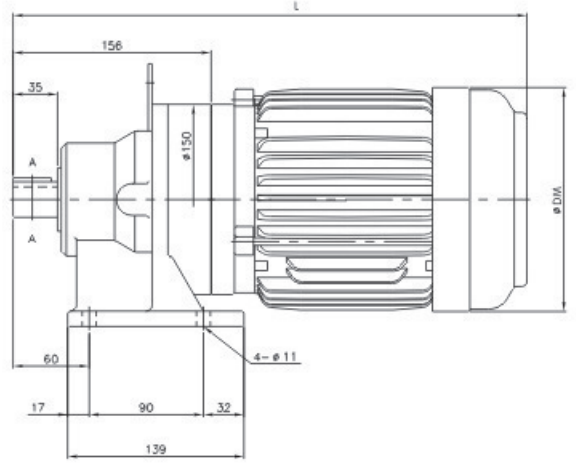
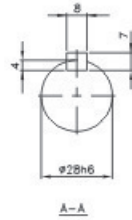
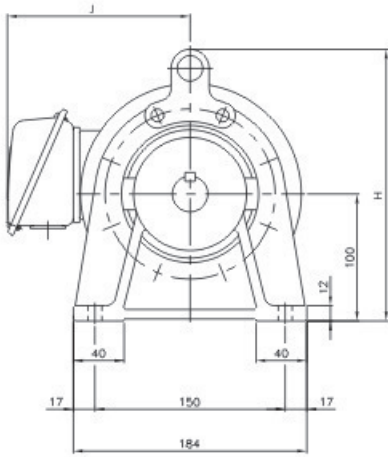

Motor			TRANSCYKO Model No.	Metric ( mm, kg )					Inches ( in.lbs )				
KW	HP	POLE		L	J	DM	H	Weight	L	J	DM	H	Weight
0.2	1/4	4	THM02-610	375	121	144	207	23	14.76	4.76	5.67	8.15	50.60
0.4	1/2	4	THM05-610	396	132	162	207	25	15.59	5.20	6.38	8.19	55.00
0.75	1	4	THM1-610	395	137	177	207	29	15.55	5.39	6.97	8.15	63.80
1.5	2	4	THM2-610	432	150	200	207	37	17.01	5.91	7.87	8.15	81.40
2.2	3	4	THM3-610	467	173	219	225	47	18.39	6.81	8.62	8.86	103.4



# THM-611

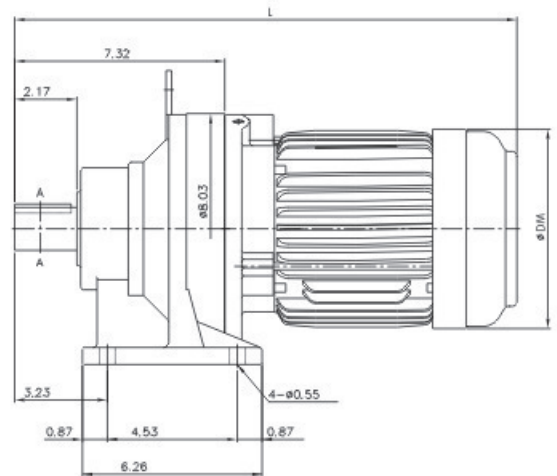
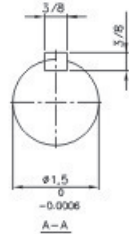
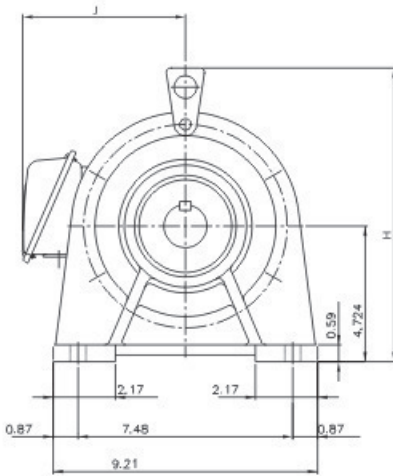
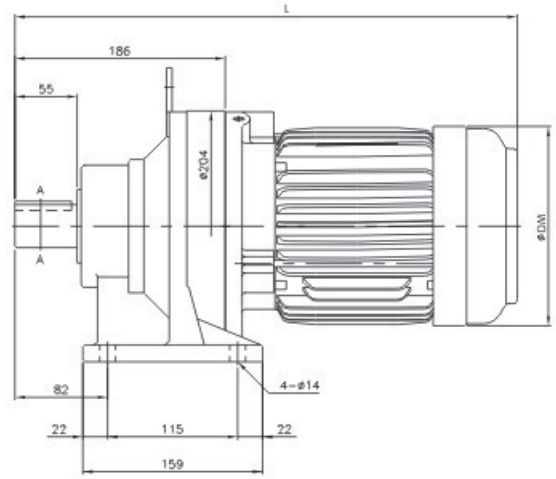
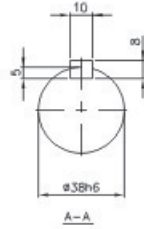
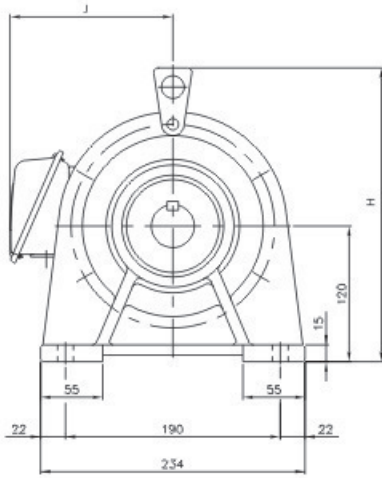

Motor			TRANSCYKO Model No.	Metric ( mm, kg )					Inches ( in.lbs )				
KW	HP	POLE		L	J	DM	H	Weight	L	J	DM	H	Weight
0.2	1/2	4	THM05-611	425	132	162	257	35	16.73	5.20	6.38	10.12	77.0
0.75	1	4	THM1-611	434	137	177	257	40	17.59	5.39	6.97	10.12	88.0
1.5	2	4	THM2-611	471	156	197	257	49	18.54	6.14	7.76	10.12	107.8
2.2	3	4	THM3-611	497	173	219	257	58	19.57	6.81	8.62	10.12	127.6
3.7	5	4	THM5-611	513	188	252	276	67	20.20	7.40	9.37	10.87	147.4

**THM-612**

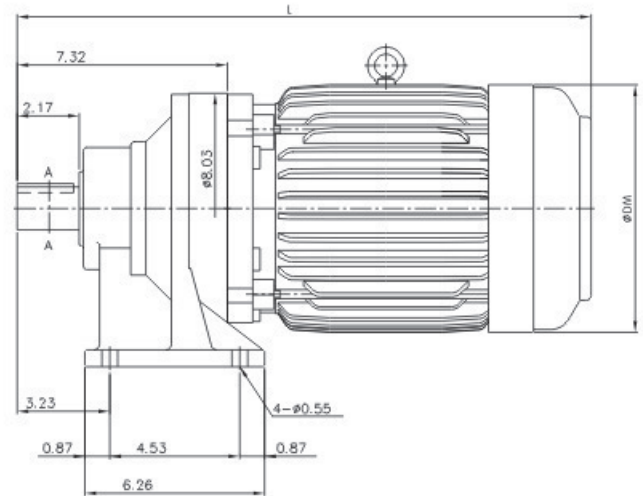
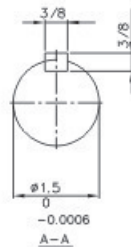
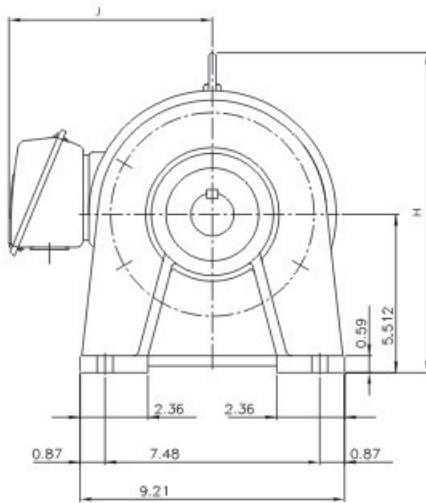
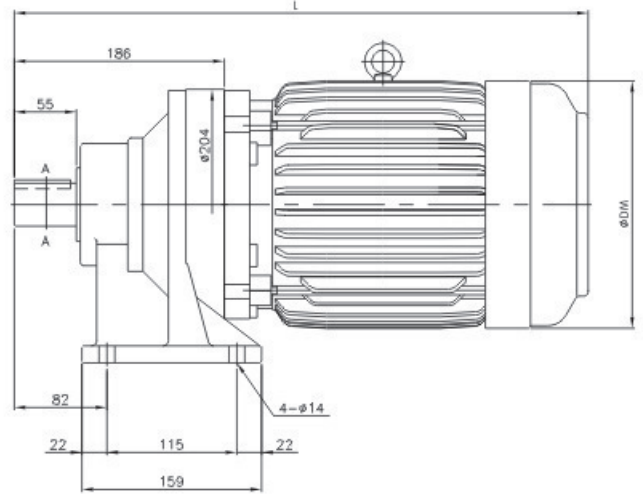
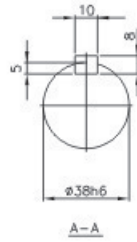
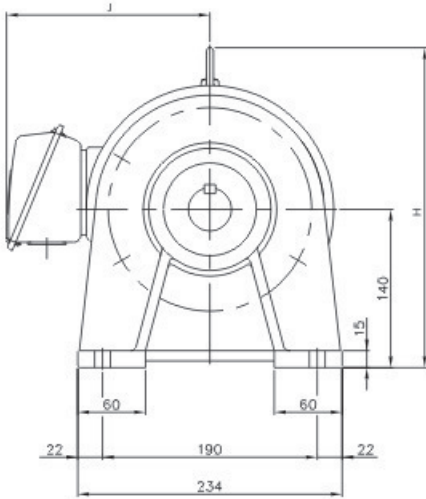

Motor			TRANSCYKO Model No.	Metric ( mm, kg )					Inches ( in.lbs )				
KW	HP	POLE		L	J	DM	H	Weight	L	J	DM	H	Weight
0.75	1	4	THM1-612	434	137	177	277	41	17.09	5.39	6.97	10.90	90.20
2.2	3	4	THM3-612	497	173	219	277	61	19.57	6.81	8.62	10.90	134.2
3.7	5	4	THM5-612	513	188	238	280	70	20.2	7.40	9.37	11.02	154.0
5.5	7.5	4	THM8-612	557	223	273	318	96	21.93	8.78	10.75	12.52	211.2



# THHM-613

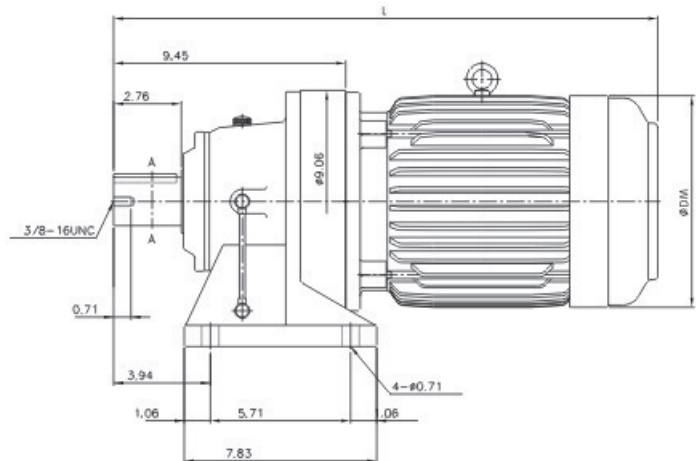
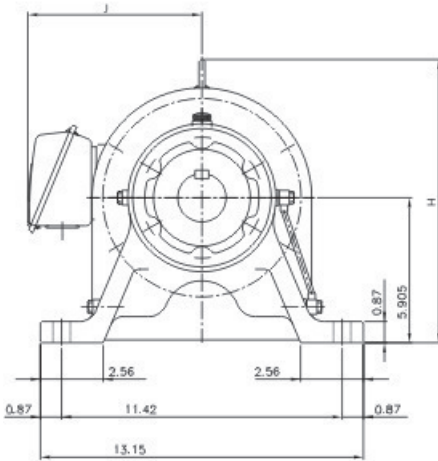
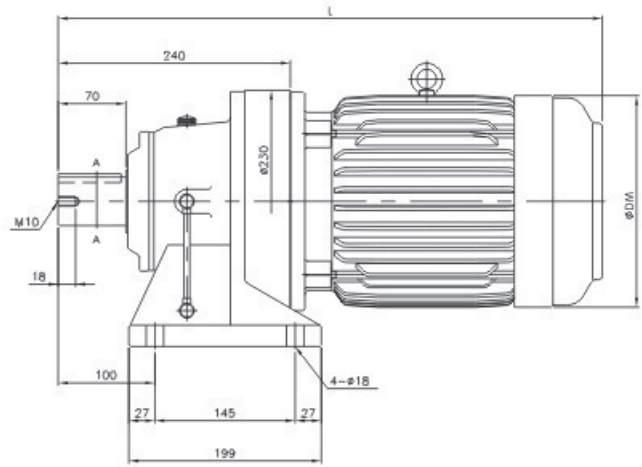
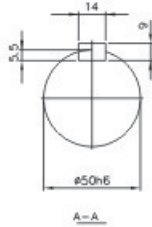
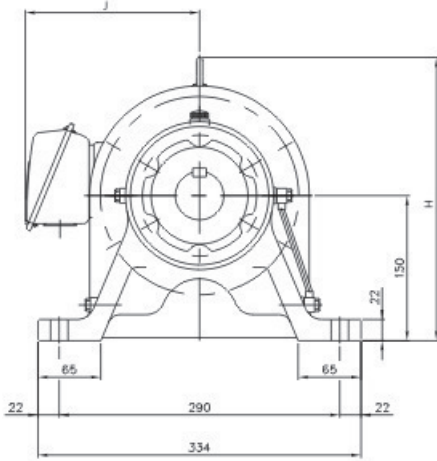

Motor			TRANSCYKO Model No.	Metric ( mm, kg )					Inches ( in.lbs )				
KW	HP	POLE		L	J	DM	H	Weight	L	J	DM	H	Weight
0.75	1	4	THHM1-613	484	143	177	300	59	19.06	5.63	6.97	11.81	129.8
1.5	2	4	THHM2-613	524	150	200	300	67	20.63	5.91	7.87	11.81	147.4
2.2	3	4	THHM3-613	551	173	219	300	79	21.69	6.81	8.62	11.81	173.8
3.7	5	4	THHM5-613	570	187	238	303	88	22.44	7.36	9.37	11.93	193.6
5.5	7.5	4	THHM8-613	614	218	273	328	104	24.17	8.58	10.75	12.91	228.2
7.5	10	4	THHM10-613	652	223	273	328	116	25.67	8.78	10.75	12.91	255.2

**THHM-614**

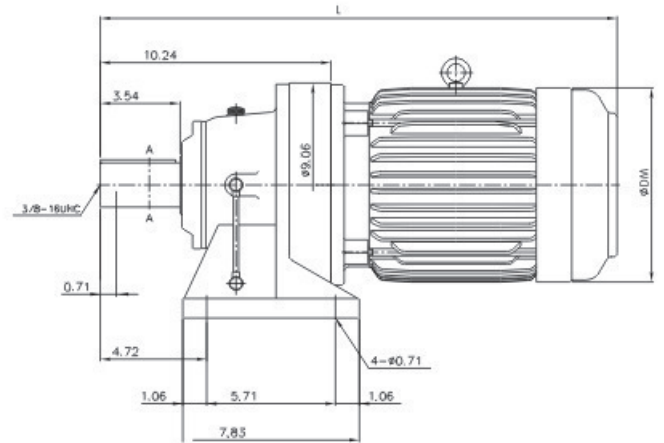
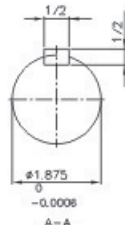
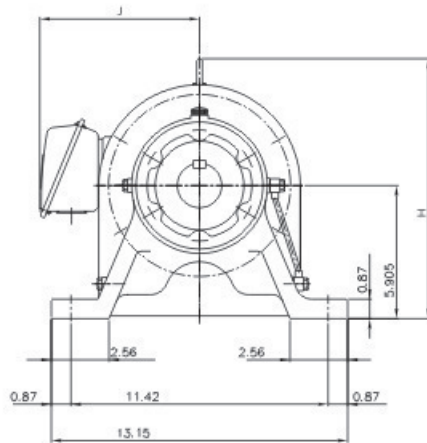
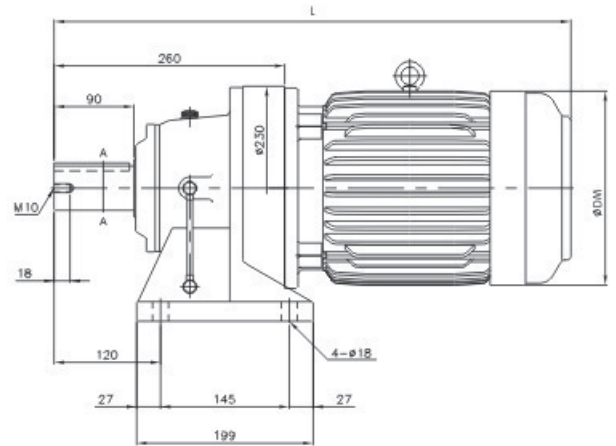
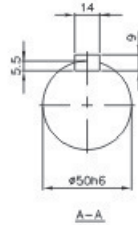
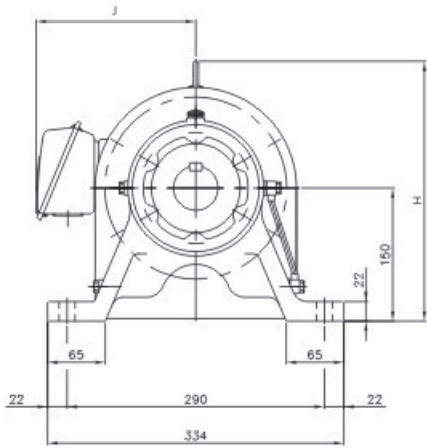

Motor			TRANSCYKO Model No.	Metric ( mm, kg )					Inches ( in.lbs )				
KW	HP	POLE		L	J	DM	H	Weight	L	J	DM	H	Weight
0.75	1	4	THHM1-614	504	143	177	300	60	19.84	5.63	6.97	11.81	132.0
1.5	2	4	THHM2-614	544	150	200	300	68	21.42	5.91	7.87	11.81	149.6
2.2	3	4	THHM3-614	571	173	219	300	80	22.48	6.81	8.62	11.81	176.0
3.7	5	4	THHM5-614	590	187	238	303	89	23.22	7.36	9.37	11.93	195.8
5.5	7.5	4	THHM8-614	634	218	273	328	104	24.96	8.58	10.75	12.91	228.8
7.5	10	4	THHM10-614	672	223	273	328	116	26.46	8.78	10.75	12.91	255.2



THHM-615

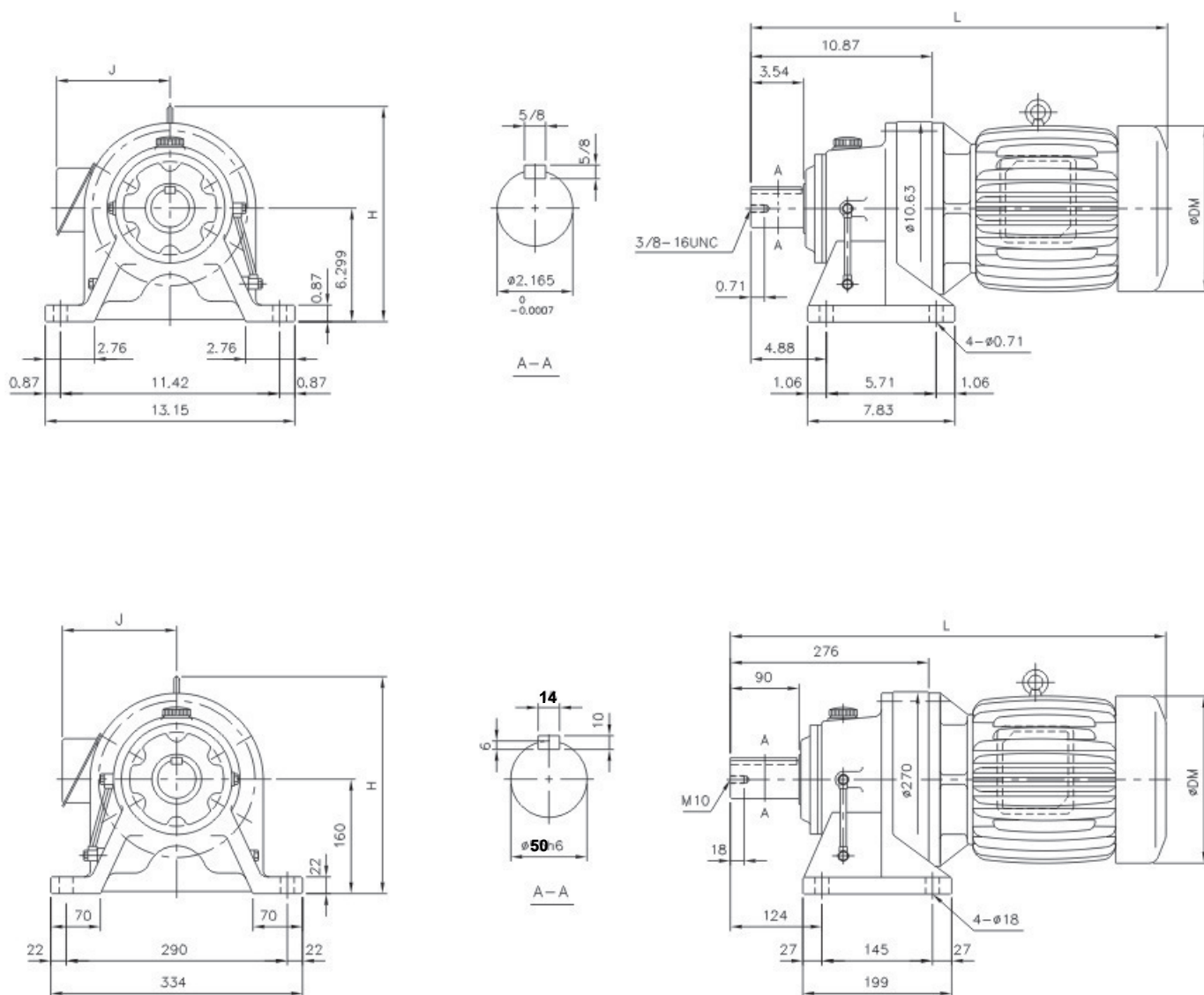

Motor			TRANSCYKO Model No.	Metric ( mm, kg )					Inches ( in.lbs )				
KW	HP	POLE		L	J	DM	H	Weight	L	J	DM	H	Weight
0.75	1	4	THHM1-615	504	143	177	310	60	19.84	5.63	6.97	12.20	132.0
1.5	2	4	THHM2-615	544	150	200	310	68	21.42	5.91	7.87	12.20	149.6
2.2	3	4	THHM3-615	571	173	219	310	80	22.48	6.81	8.62	12.20	176.0
3.7	5	4	THHM5-615	590	187	238	313	91	23.23	7.36	9.37	12.32	200.2
5.5	7.5	4	THHM8-615	634	218	273	338	107	24.96	8.58	10.75	13.31	235.4
7.5	10	4	THHM10-615	672	223	273	338	119	26.46	8.78	10.75	13.31	261.8
11	15	4	THHM15-615	752	256	334	362	150	29.61	10.08	13.15	14.25	330.0

# THHM-616

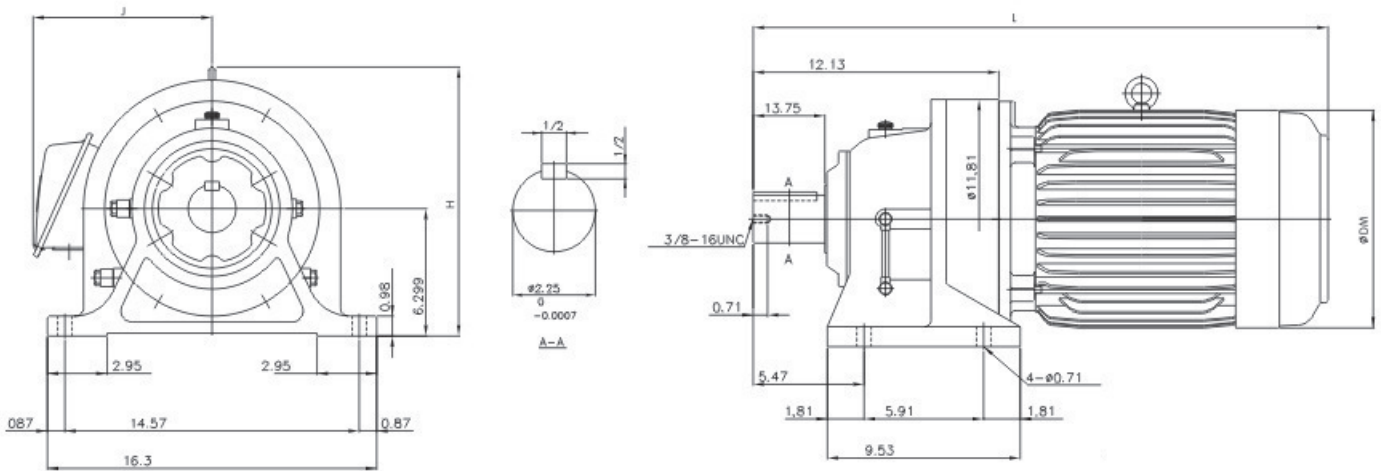
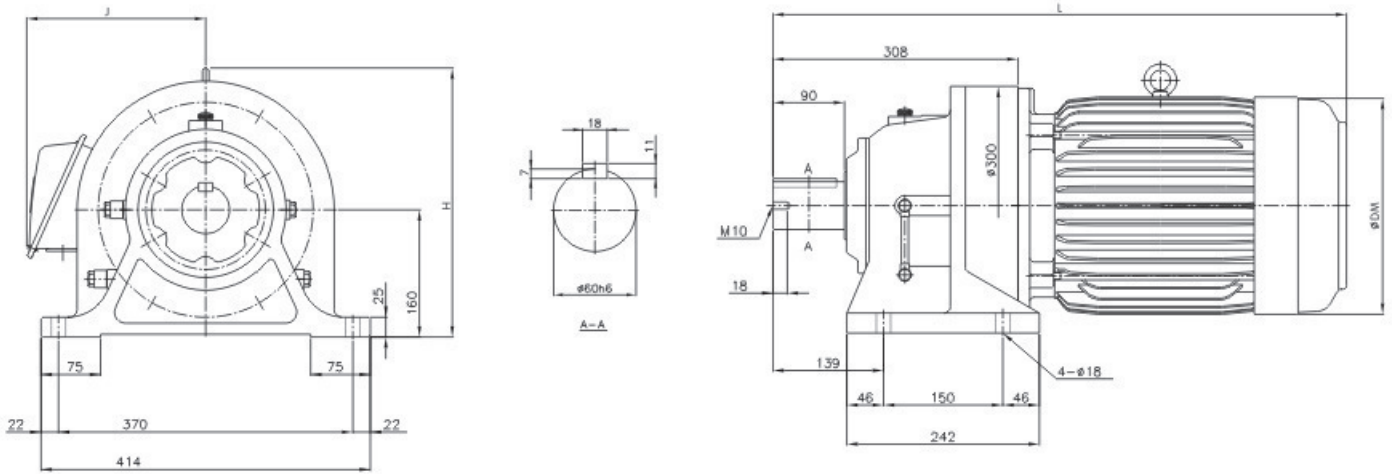

Motor			TRANSCYKO Model No.	Metric ( mm, kg )					Inches ( in.lbs )				
KW	HP	POLE		L	J	DM	H	Weight	L	J	DM	H	Weight
0.75	2	4	THHM2-616	593	150	200	320	109	23.35	5.91	7.87	12.60	239.8
2.2	3	4	THHM3-616	622	173	219	320	120	24.49	6.81	8.62	12.60	264.0
3.7	5	4	THHM5-616	641	182	238	320	129	25.24	7.17	9.37	12.60	238.8
5.5	7.5	4	THHM8-616	675	219	273	338	145	26.57	8.62	13.31	13.31	319.0
7.5	10	4	THHM10-616	713	219	273	338	157	28.07	8.62	13.31	13.31	345.4
11	15	4	THHM15-616	800	256	334	377	189	31.05	10.08	14.84	14.84	415.8
15	20	4	THHM20-616	844	256	334	377	208	33.23	10.08	14.84	14.84	457.6



# THHM-617

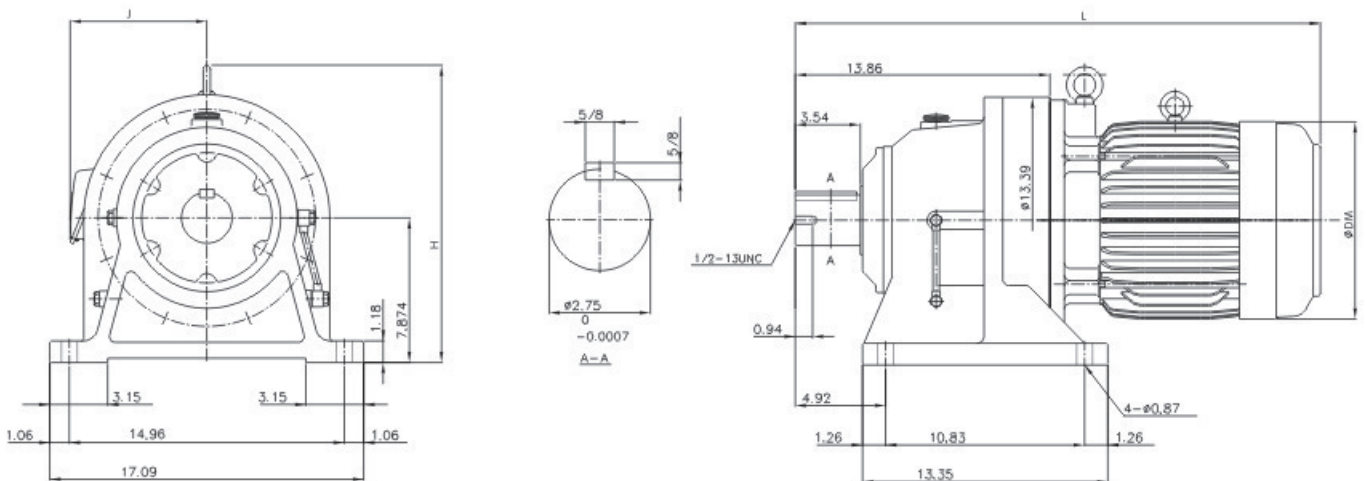
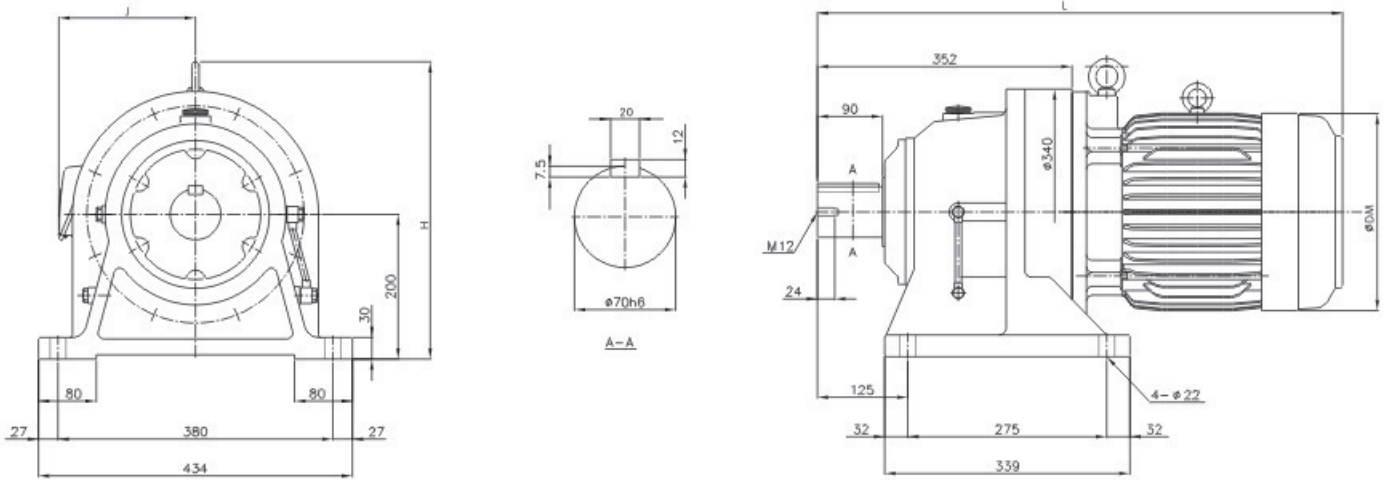

Motor			TRANSCYKO Model No.	Metric ( mm, kg )					Inches ( in.lbs )				
KW	HP	POLE		L	J	DM	H	Weight	L	J	DM	H	Weight
3.7	5	4	THHM5-617	697	132	238	411	172	27.44	7.17	9.37	16.18	378.4
5.5	7.5	4	THHM8-617	731	218	273	411	189	28.78	8.58	10.75	16.18	415.8
7.5	10	4	THHM10-617	769	218	273	411	200	30.28	8.58	10.75	16.18	440.0
11	15	4	THHM15-617	844	256	334	411	220	33.23	10.08	13.15	16.18	484.0
15	20	4	THHM20-617	888	256	334	411	235	34.96	10.08	13.15	16.18	517.0
18.5	25	4	THHM25-617	911	305	382	430	303	35.87	12.01	15.04	16.93	666.6
22	30	4	THHM30-617	911	305	382	430	303	35.87	12.01	15.04	16.93	666.6

# THHM-618

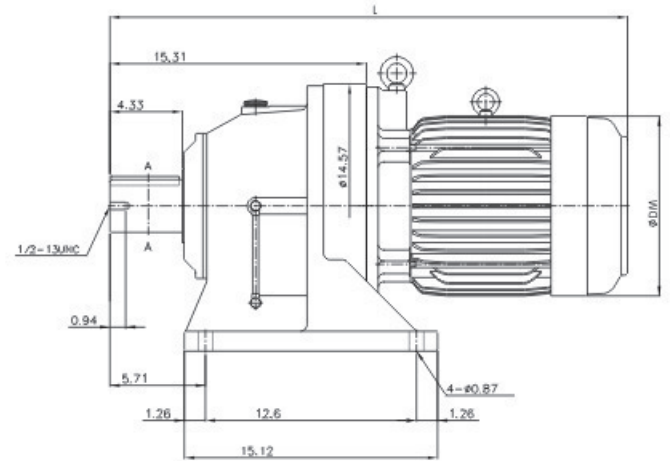
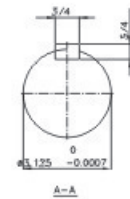
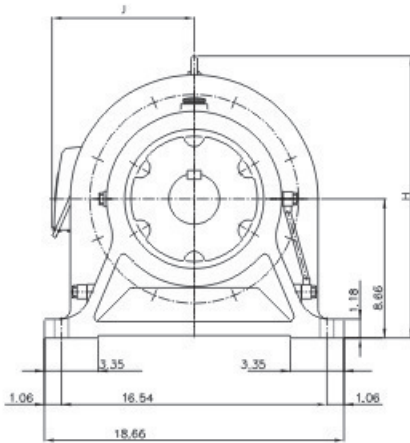
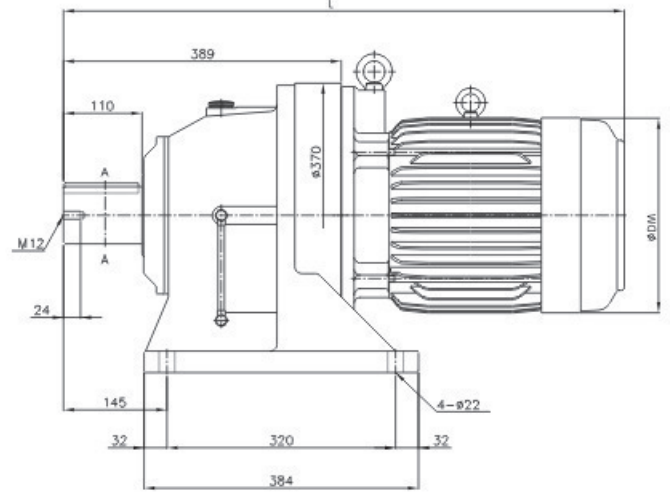
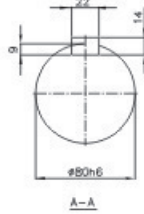
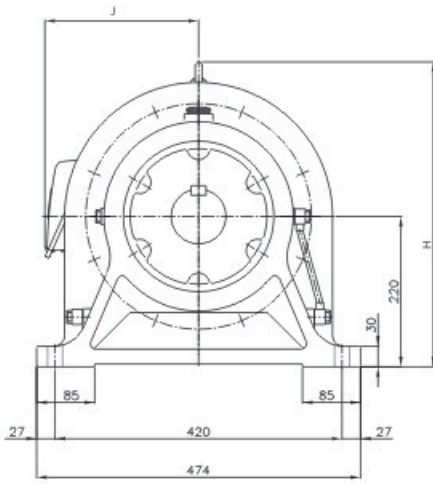

Motor			TRANSCYKO Model No.	Metric ( mm, kg )					Inches ( in.lbs )				
KW	HP	POLE		L	J	DM	H	Weight	L	J	DM	H	Weight
3.7	5	4	THHM5-618	756	182	238	446	185	29.76	7.17	9.37	17.56	407.0
5.5	7.5	4	THHM8-618	775	218	273	446	192	30.51	8.58	10.75	17.56	422.8
7.5	10	4	THHM10-618	815	218	273	446	205	32.09	8.58	10.75	17.56	451.0
11	15	4	THHM15-618	883	224	334	446	219	34.76	8.82	13.15	17.56	481.8
15	20	4	THHM20-618	927	256	334	446	279	36.50	10.08	13.15	17.56	613.8
18.5	25	4	THHM25-618	950	305	382	460	343	37.40	10.08	15.04	18.11	750.2
22	30	4	THHM30-618	950	305	382	460	343	37.40	12.01	15.04	18.11	754.2
30	40	4	THHM40-618	988	305	382	460	343	38.90	12.01	15.04	18.11	754.6



# THHM-619

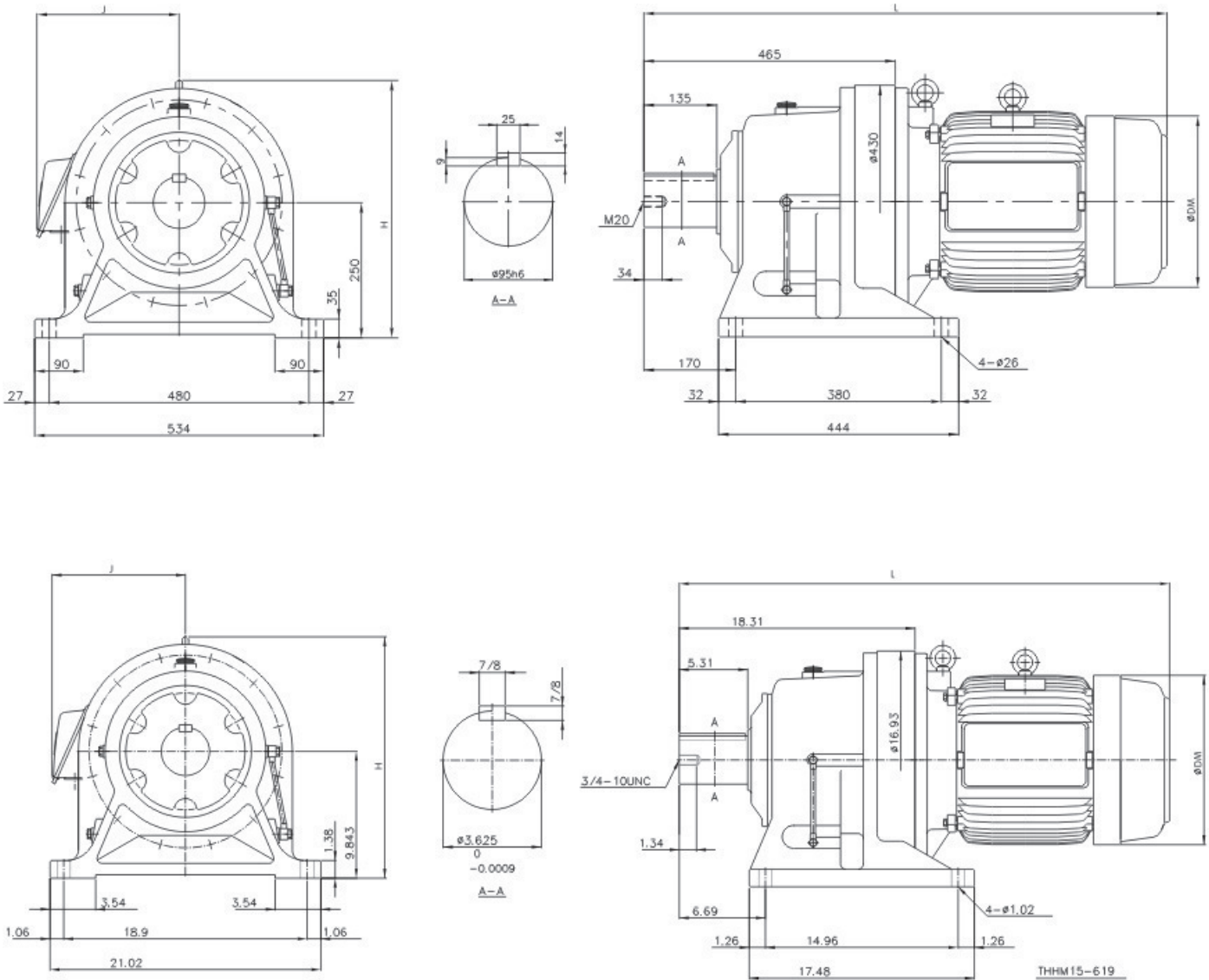

Motor			TRANSCYKO Model No.	Metric ( mm, kg )					Inches ( in.lbs )				
KW	HP	POLE		L	J	DM	H	Weight	L	J	DM	H	Weight
5.5	7.5	4	THHM8-619	850	224	273	511	301	33.46	8.82	10.75	20.12	662.2
7.5	10	4	THHM10-619	888	224	273	511	313	34.96	8.82	10.75	20.12	688.6
11	15	4	THHM15-619	963	261	334	511	332	37.91	10.28	13.15	20.12	730.4
15	20	4	THHM20-619	1007	261	334	511	334	39.65	10.28	13.15	20.12	756.8
18.5	25	4	THHM25-619	1026	305	382	511	416	40.39	12.01	15.04	20.12	915.2
22	30	4	THHM30-619	1026	305	382	511	416	40.39	12.01	15.04	20.12	915.2
30	40	4	THHM40-619	1026	305	382	511	431	40.39	12.01	15.04	20.12	948.2
37	50	4	THHM50-619	1127	339	420	511	468	44.37	13.35	16.54	20.12	1030

# THHM-620

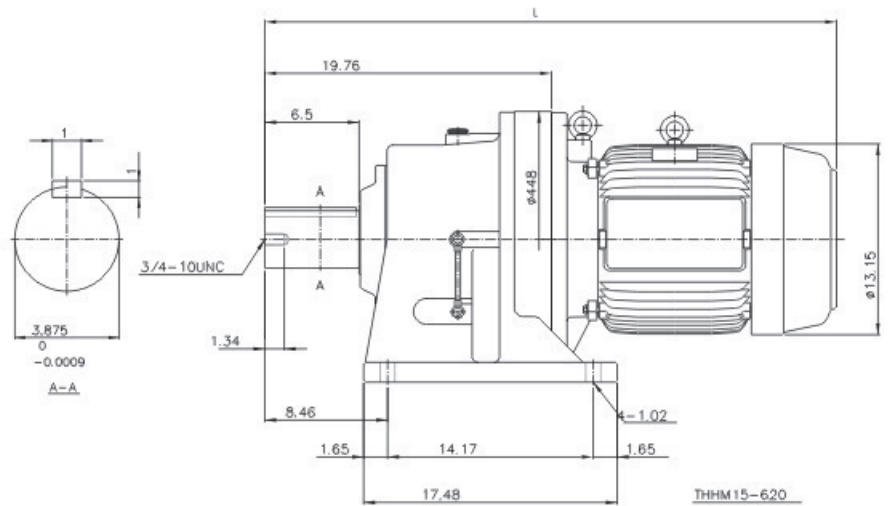
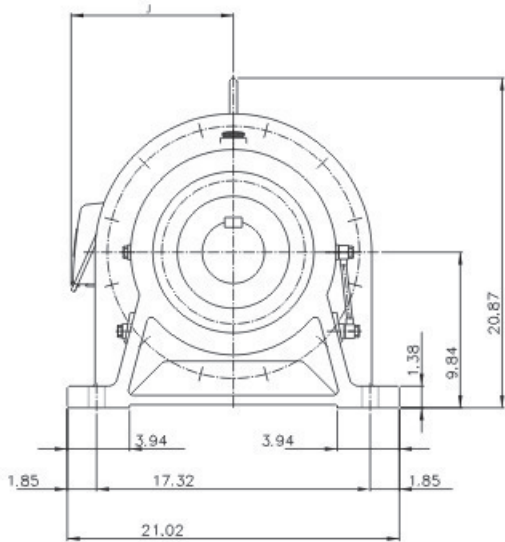
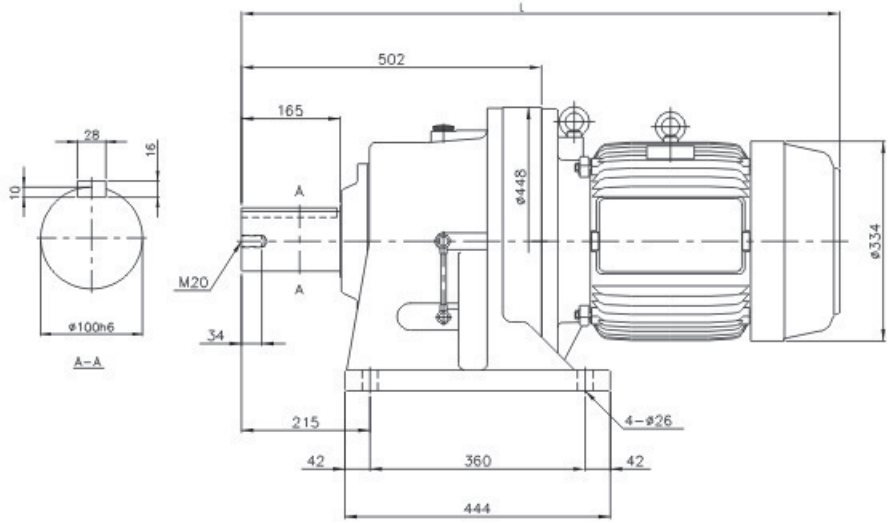
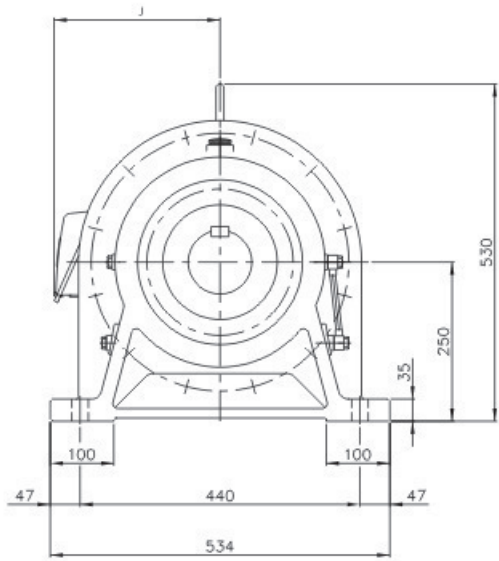

Motor			TRANSCYKO Model No.	Metric ( mm, kg )					Inches ( in.lbs )				
KW	HP	POLE		L	J	DM	H	Weight	L	J	DM	H	Weight
11	5	4	THHM15-620	1001	261	334		313	39.41	10.28	13.15		688.6
15	7.5	4	THHM20-620	1045	261	334		367	41.14	10.28	13.15		807.4
18.5	10	4	THHM25-620	1064	305	328		437	41.89	12.01	15.04		961.4
22	15	4	THHM30-620	1064	305	328		437	41.89	12.01	15.04		961.4
30	20	4	THHM40-620	1102	305	328		450	43.39	12.01	15.04		990.0
37	25	4	THHM50-620	1165	339	420		487	45.87	13.35	16.54		1071
45	30	4	THHM60-620	1165	339	420		487	45.87	13.35	16.54		1071



**THHM-621**

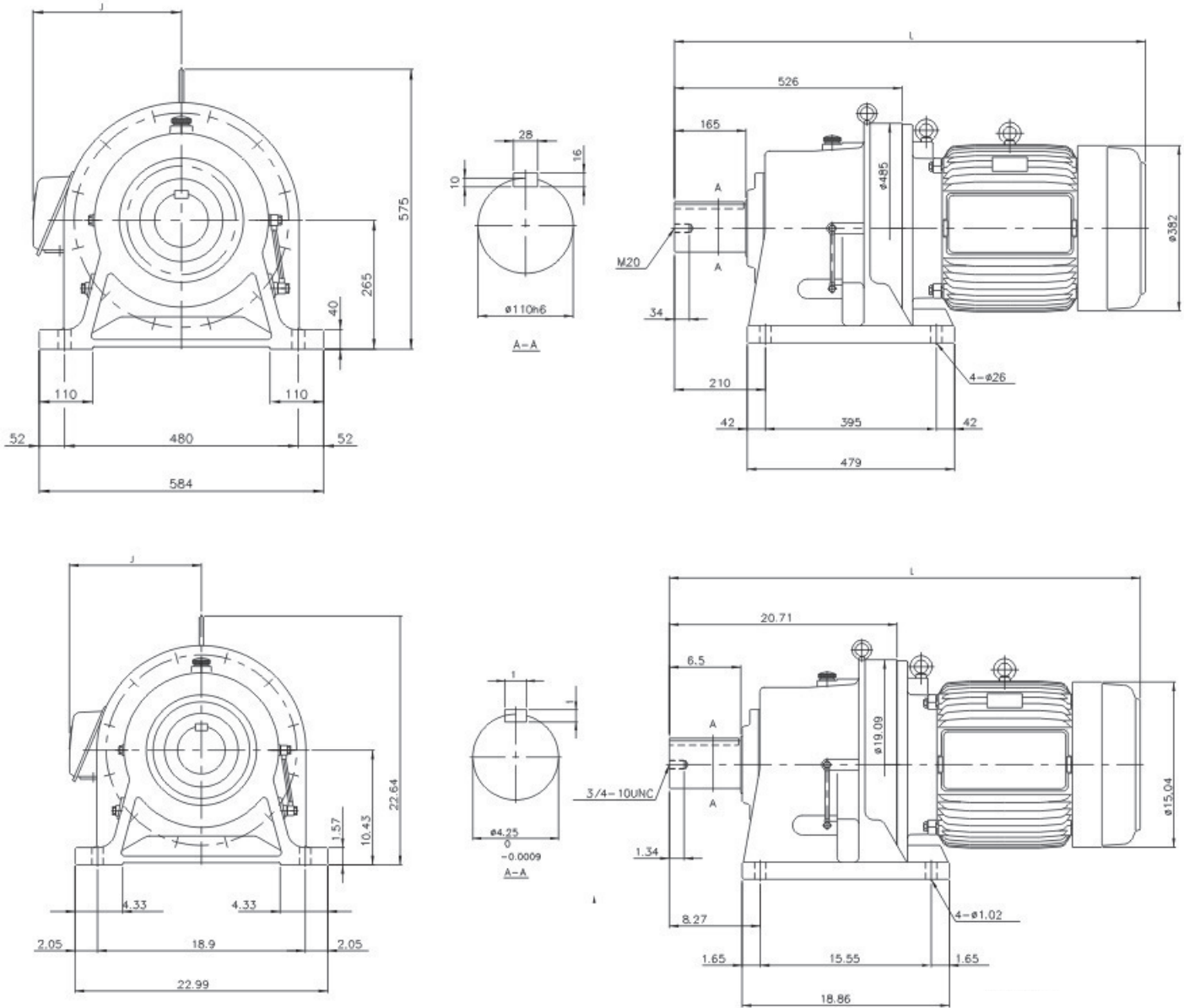

Motor			TRANSCYKO Model No.	Metric ( mm, kg )					Inches ( in.lbs )				
KW	HP	POLE		L	J	DM	H	Weight	L	J	DM	H	Weight
11	15	4	THHM15-621	1025	261	334		396	40.35	10.28	13.15		871.2
15	20	4	THHM20-621	1069	261	334		454	42.09	10.28	13.15		992.2
18.5	25	4	THHM25-621	1088	305	382		514	42.83	12.01	15.04		1131
22	30	4	THHM30-621	1088	305	382		514	42.83	12.01	15.04		1131
30	40	4	THHM40-621	1126	305	382		527	44.33	12.01	15.04		1159
37	50	4	THHM50-621	1189	339	420		559	46.81	13.35	16.54		1230
45	60	4	THHM60-621	1189	339	420		559	46.81	13.35	16.54		1230
55	75	4	THHM75-621	1227	387	458		674	48.31	15.24	18.03		1483

THHM-622

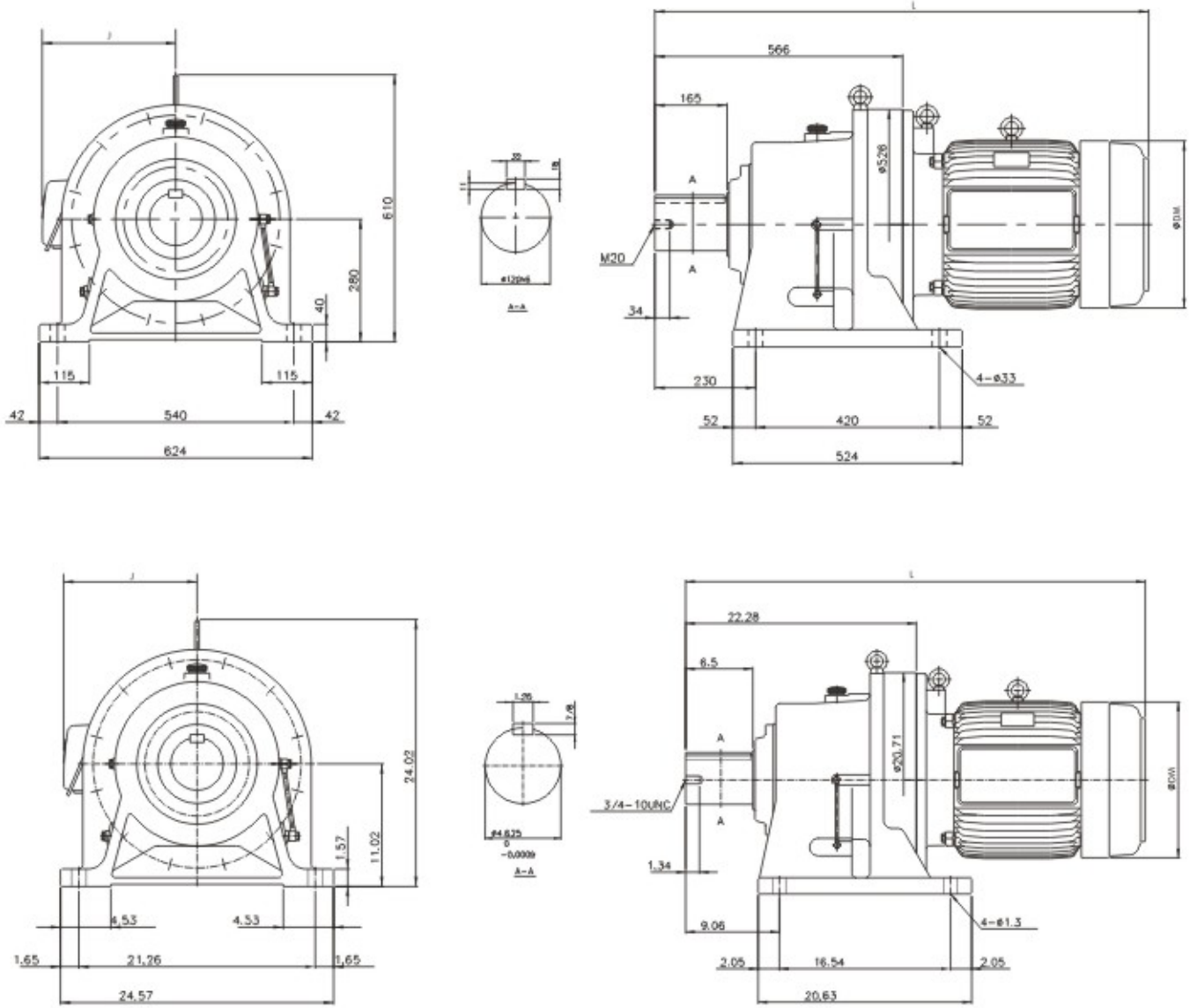

Motor			TRANSCYKO Model No.	Metric ( mm, kg )					Inches ( in.lbs )				
KW	HP	POLE		L	J	DM	H	Weight	L	J	DM	H	Weight
18.5	25	4	THHM25-622	1128	305	382		599	44.41	12.01	15.04		1318
22	30	4	THHM30-622	1128	305	382		599	44.41	12.01	15.04		1318
30	40	4	THHM40-622	1166	305	382		612	45.91	12.01	15.04		1346
37	50	4	THHM50-622	1229	339	420		650	48.39	13.35	16.50		1430
45	60	4	THHM60-622	1229	339	420		650	48.39	13.35	16.54		1430
55	75	4	THHM75-622	1289	387	458		749	50.75	13.35	18.03		1648



THHM-623

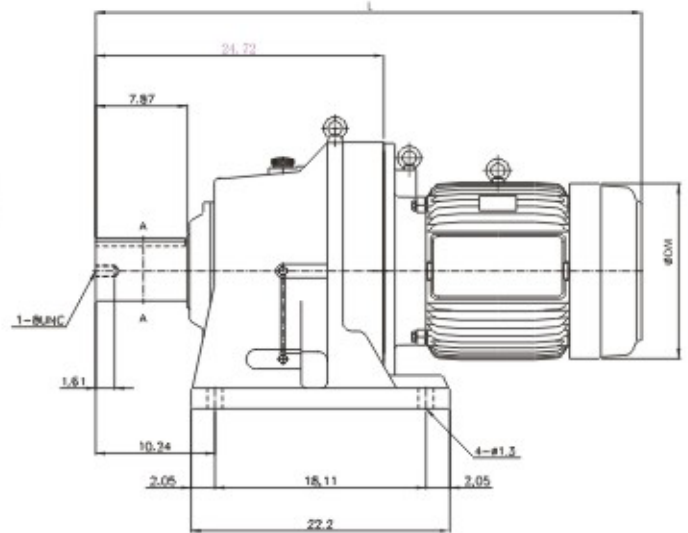
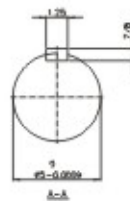
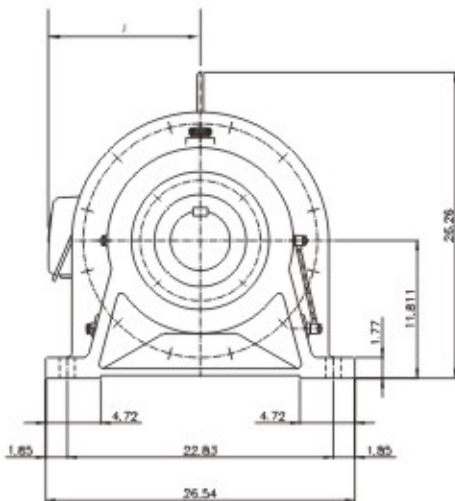
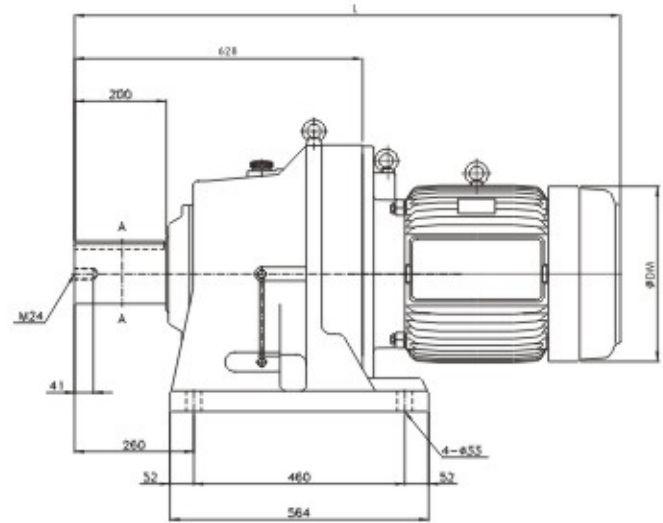
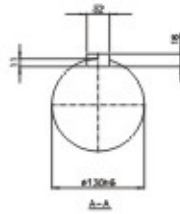
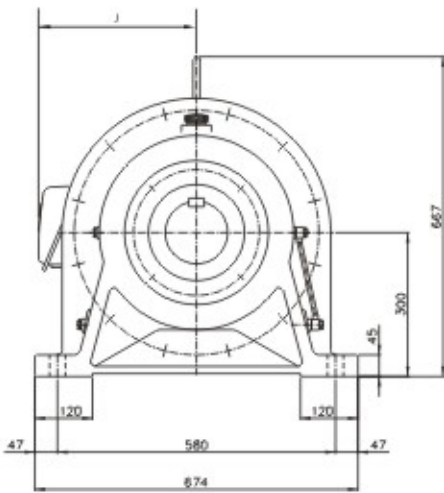

Motor			TRANSCYKO Model No.	Metric ( mm, kg )					Inches ( in.lbs )				
KW	HP	POLE		L	J	DM	H	Weight	L	J	DM	H	Weight
35	20	6	THHM20/6-623	1200	305	382		697	47.24	12.01	15.04		1533
18.5	25	6	THHM25/6-623	1238	305	382		697	48.74	12.01	15.04		1533
22	30	6	THHM30/6-623	1238	305	382		697	48.74	12.01	15.04		1533
30	40	6	THHM40/6-623	1400	339	420		743	55.12	13.35	16.54		1635
37	50	6	THHM50/6-623	1430	339	420		743	55.12	13.35	16.54		1635
45	60	6	THHM60/6-623	1165	387	458		832	56.30	15.24	18.03		1830
55	75	6	THHM75/6-623	1165	515	542		886	58.74	15.24	21.34		1949

THHM-624

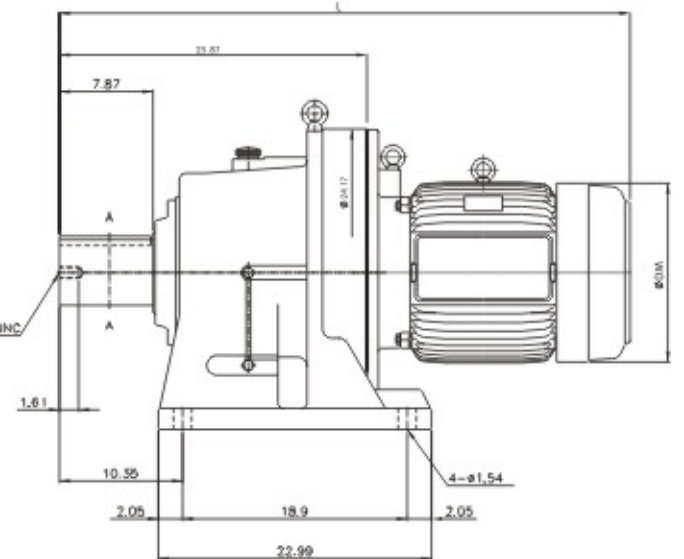
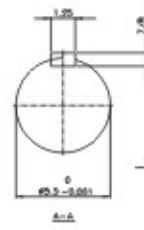
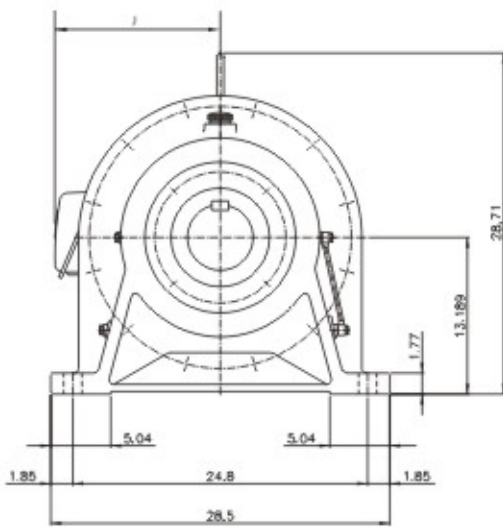
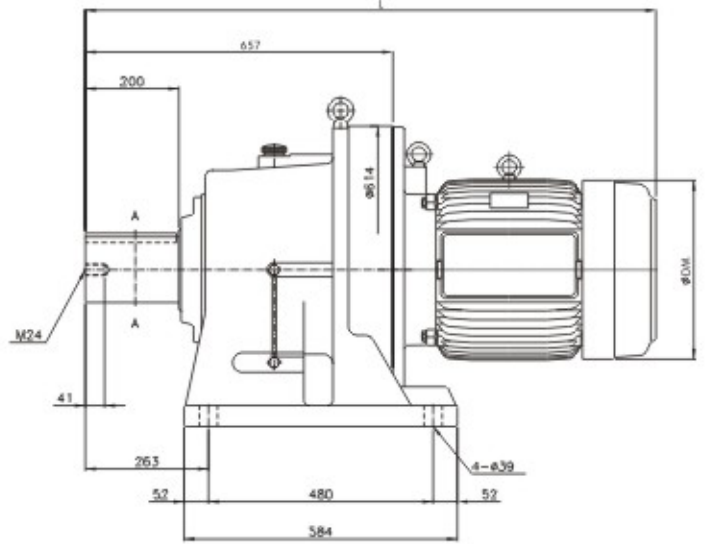
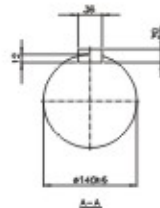
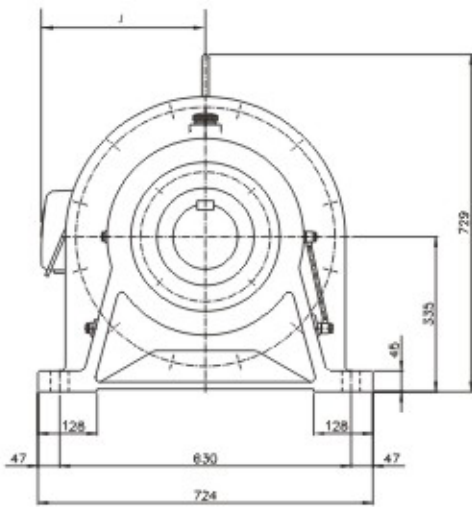

Motor			TRANSCYKO Model No.	Metric ( mm, kg )					Inches ( in.lbs )				
KW	HP	POLE		L	J	DM	H	Weight	L	J	DM	H	Weight
15	20	6	THHM20/6-624	1225	305	382		818	48.23	12.01	15.04		1800
18.5	25	6	THHM25/6-624	1263	305	382		818	49.72	12.01	15.04		1800
22	30	6	THHM30/6-624	1263	305	382		818	49.72	12.01	15.04		1800
30	40	6	THHM40/6-624	1345	339	420		864	52.95	13.35	16.54		1901
37	50	6	THHM50/6-624	1345	339	420		864	52.95	13.35	16.54		1901
45	60	6	THHM60/6-624	1383	387	458		955	54.45	15.24	18.03		2101
55	75	6	THHM75/6-624	1572	515	542		1004	61.89	20.28	21.34		2209



THHM-625

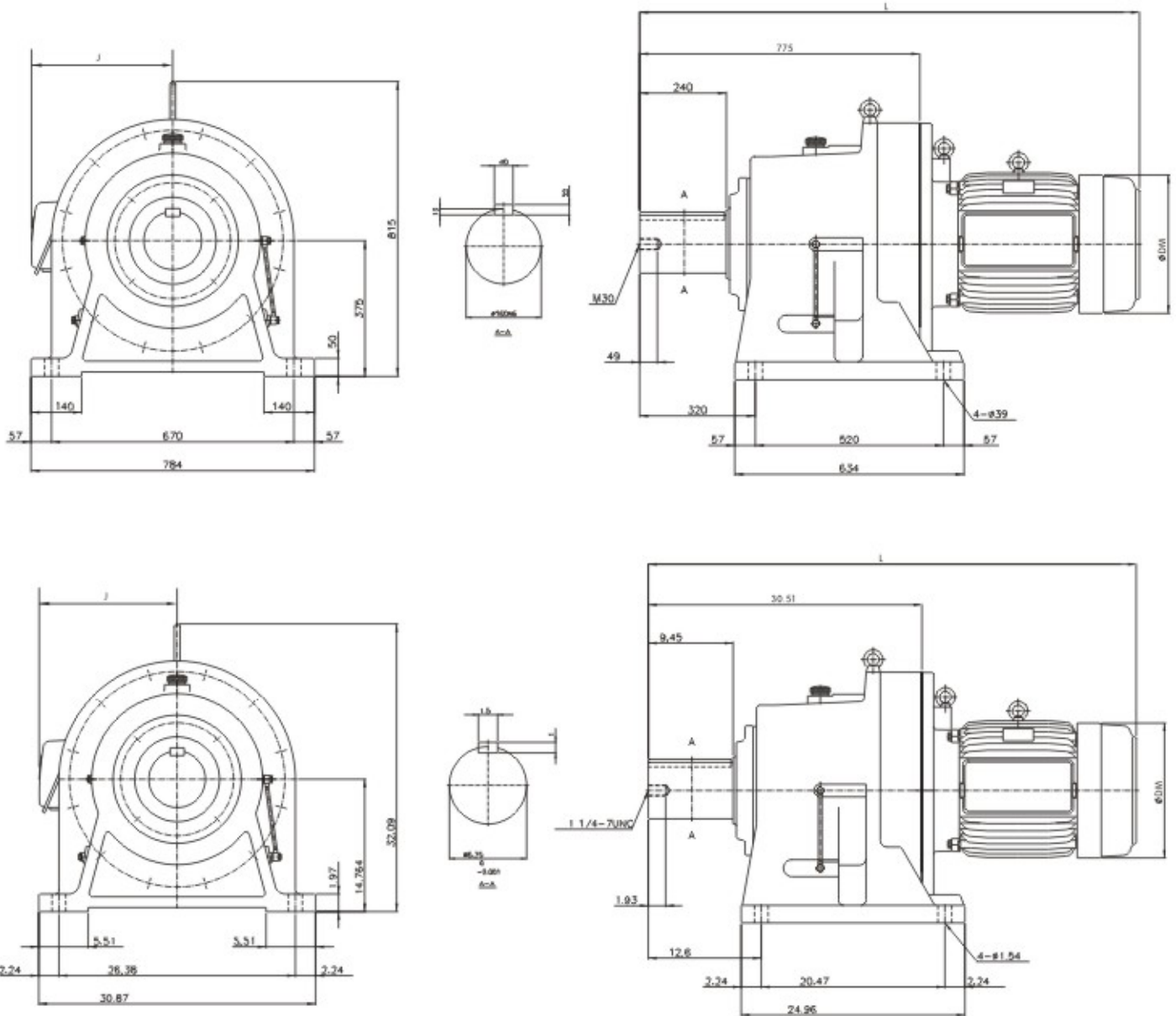

Motor			TRANSCYKO Model No.	Metric ( mm, kg )					Inches ( in.lbs )				
KW	HP	POLE		L	J	DM	H	Weight	L	J	DM	H	Weight
15	20	6	THHM20/6/625	1352	305	382		1132	53.23	10.28	13.15		2490
18.5	25	6	THHM25/6-625	1390	305	382		1149	54.72	12.01	15.04		2528
22	30	6	THHM30/6-625	1390	305	382		1149	54.72	12.01	15.04		2528
30	40	6	THHM40/6-625	1453	339	420		1193	57.20	13.35	16.54		2625
37	50	6	THHM50/6-625	1453	339	420		1193	57.20	13.35	16.54		2625
45	60	6	THHM60/6-625	1491	387	458		1273	58.70	15.24	18.03		2801
55	75	6	THHM75/6-625	1540	515	542		1328	60.63	20.28	21.34		2922

THHM-626

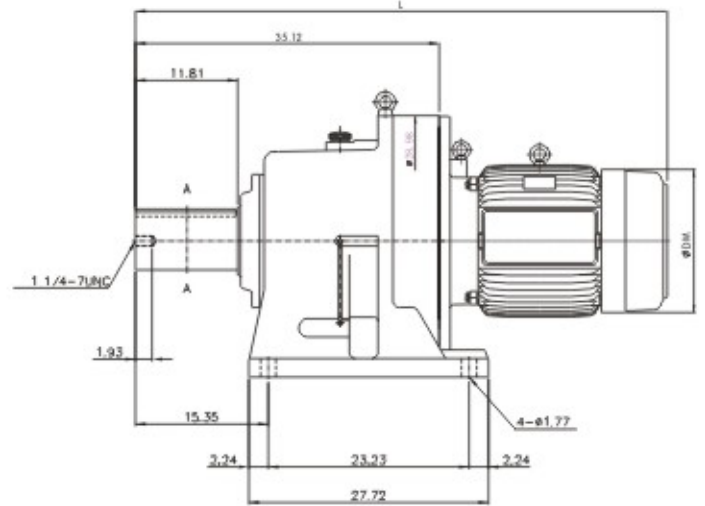
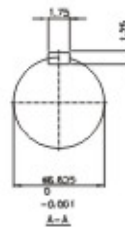
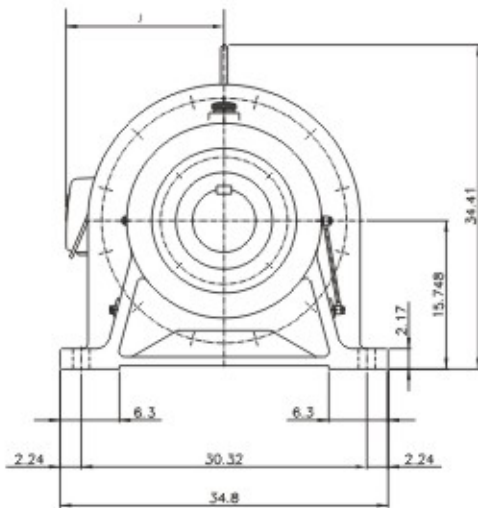
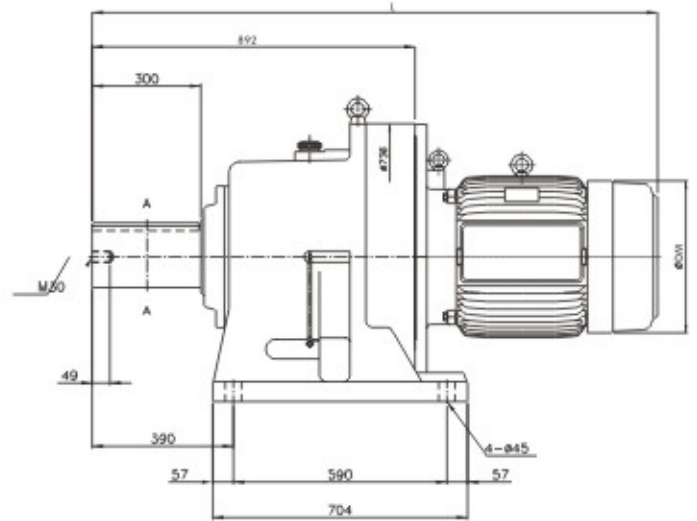
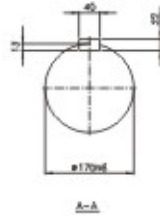
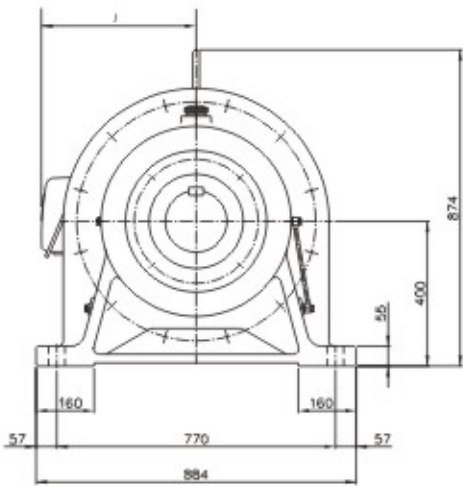

Motor			TRANSCYKO Model No.	Metric ( mm, kg )					Inches ( in.lbs )				
KW	HP	POLE		L	J	DM	H	Weight	L	J	DM	H	Weight
30	40	6	THM40/6-626	1570	339	420		1439	61.81	13.35	16.54		3166
37	50	6	THM50/6-626	1570	339	420		1439	61.81	13.35	16.54		3166
45	60	6	THHM60/6-626	1608	387	458		1534	63.31	15.24	18.03		3375



# DIMENSION DRAWINGS

For Double Stage Reduction, Horizontal TRANSCYKO Gearmotor

THM-607/07

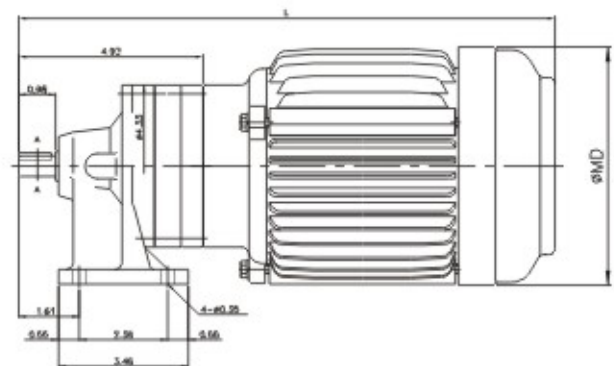
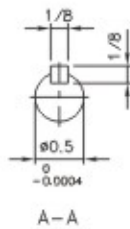
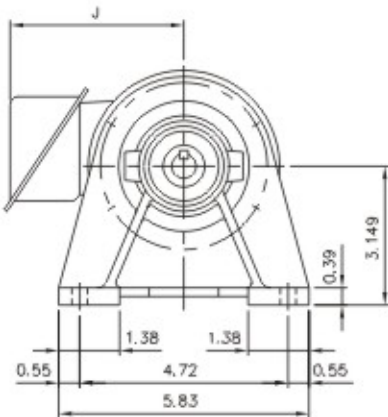
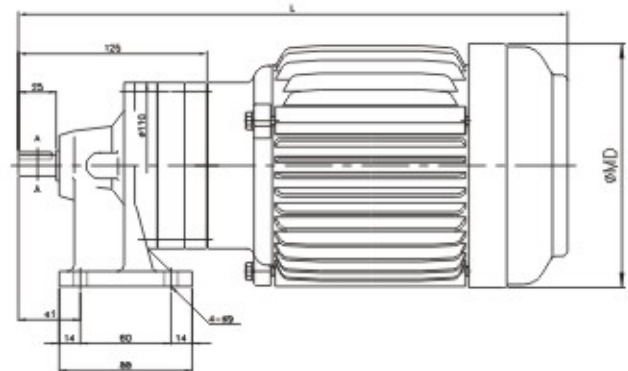
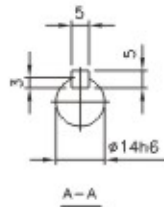
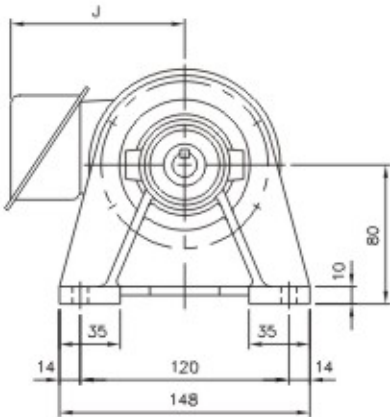

Motor			TRANSCYKO Model No.	Metric ( mm, kg )					Inches ( in.lbs )				
KW	HP	POLE		L	J	DM	H	Weight	L	J	DM	H	Weight
0.1	1/8	4	THM01-607/07	344	121	144		14	13.54	4.76	5.67		30.8





THHM-609/08

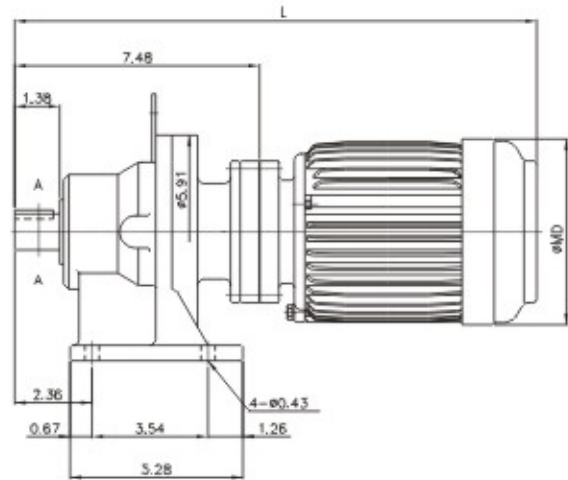
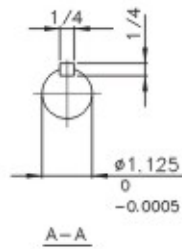
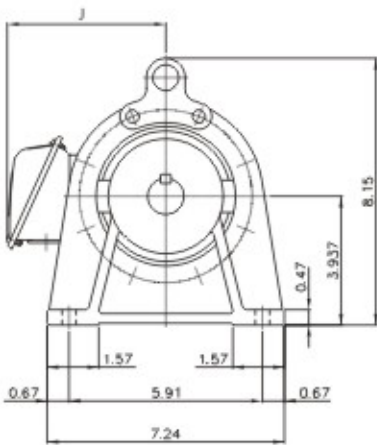
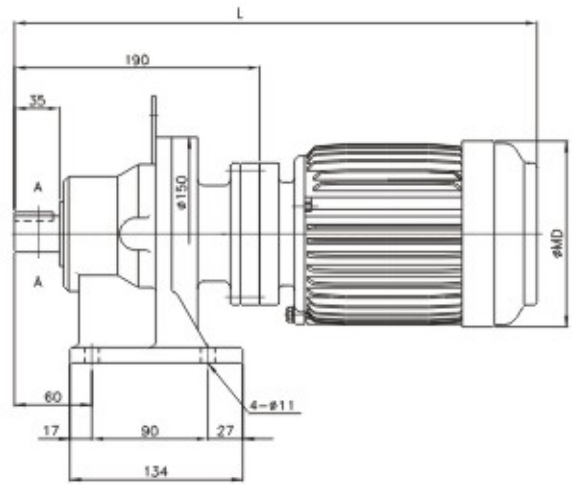
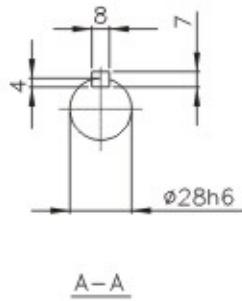
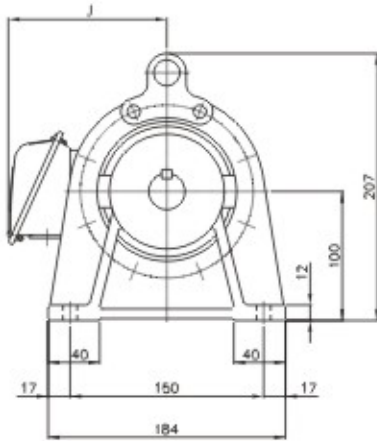

Motor			TRANSCYKO Model No.	Metric ( mm, kg )					Inches ( in.lbs )				
KW	HP	POLE		L	J	DM	H	Weight	L	J	DM	H	Weight
0.2	1/4	4	THM02-609/08	409	121	144		22	16.10	4.76	5.67		48.4

**THM-610/08**

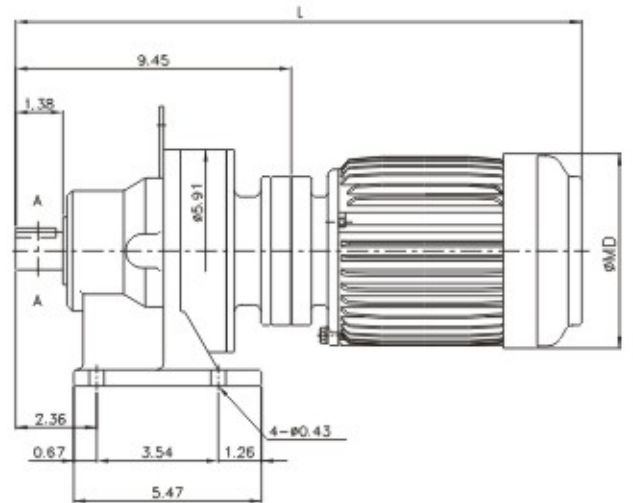
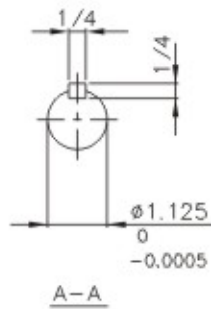
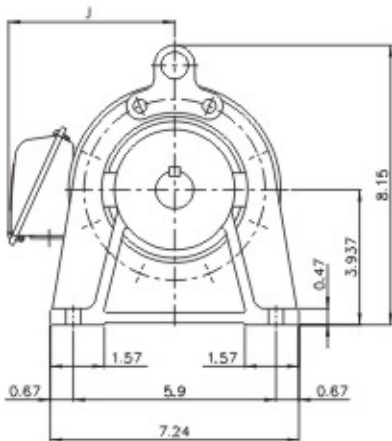
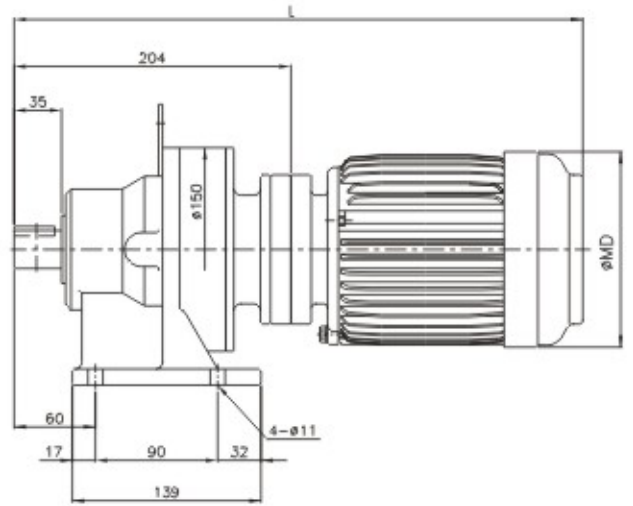
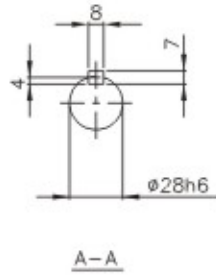
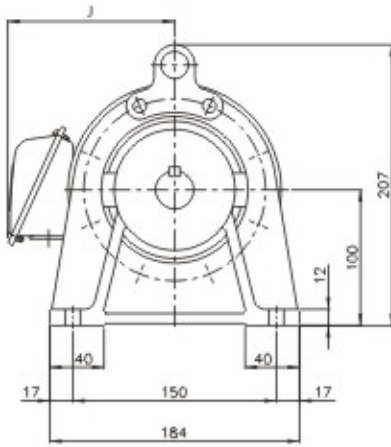

Motor			TRANSCYKO Model No.	Metric ( mm, kg )					Inches ( in.lbs )				
KW	HP	POLE		L	J	DM	H	Weight	L	J	DM	H	Weight
0.2	1/4	4	THM02-610/08	423	121	144		24	16.65	4.76	5.67		52.8
0.4	1/2	4	THM05-610/08	444	132	162		27	17.48	5.20	6.38		59.4



THHM-611/08

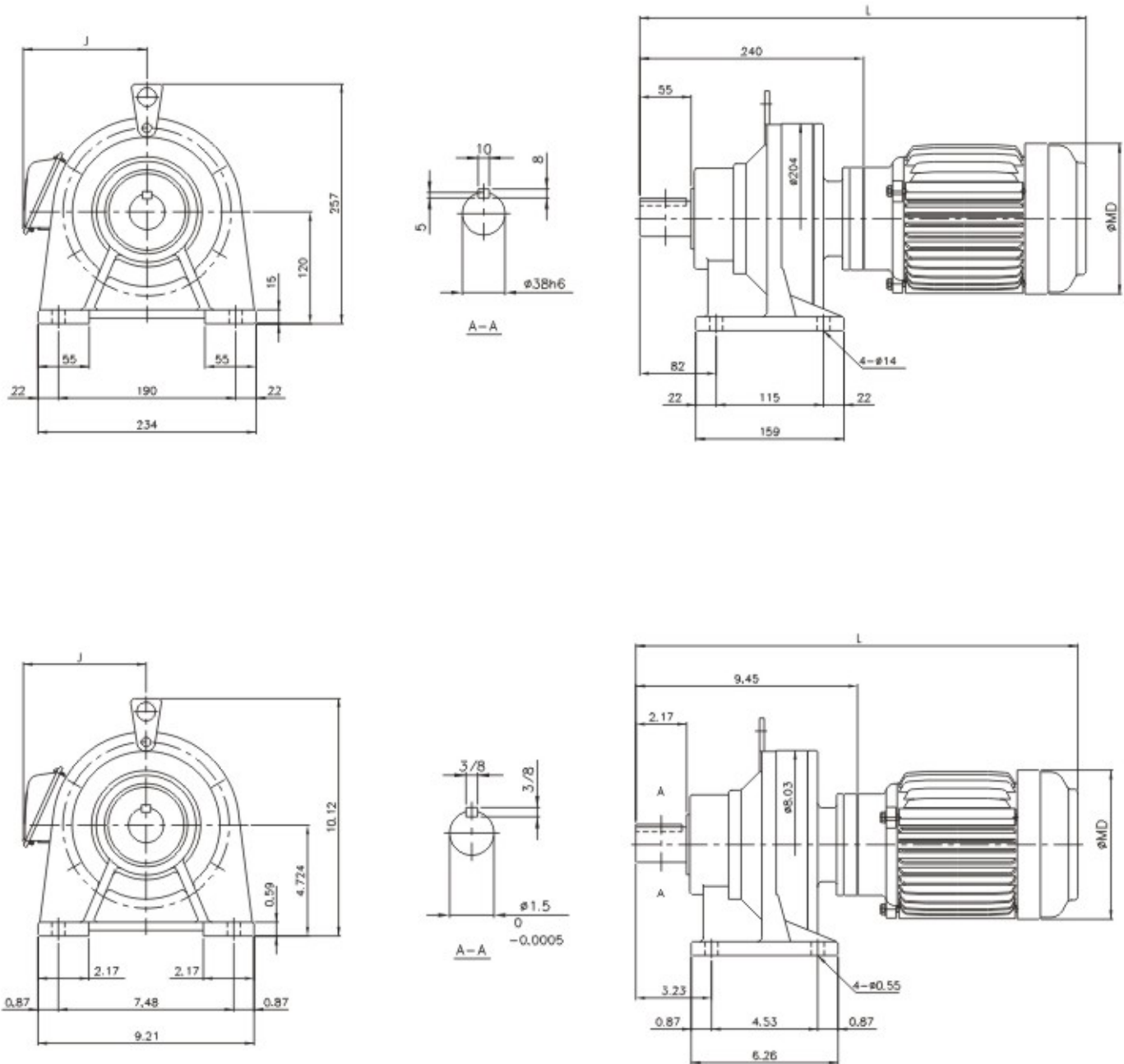

Motor			TRANSCYKO Model No.	Metric ( mm, kg )					Inches ( in.lbs )				
KW	HP	POLE		L	J	DM	H	Weight	L	J	DM	H	Weight
0.2	1/4	4	THM02-611/08	459	121	144		34	17.13	4.76	5.67		74.8
0.4	1/2	4	THM05-611/08	480	132	167		38	17.99	5.20	6.38		83.6

THM-611/09

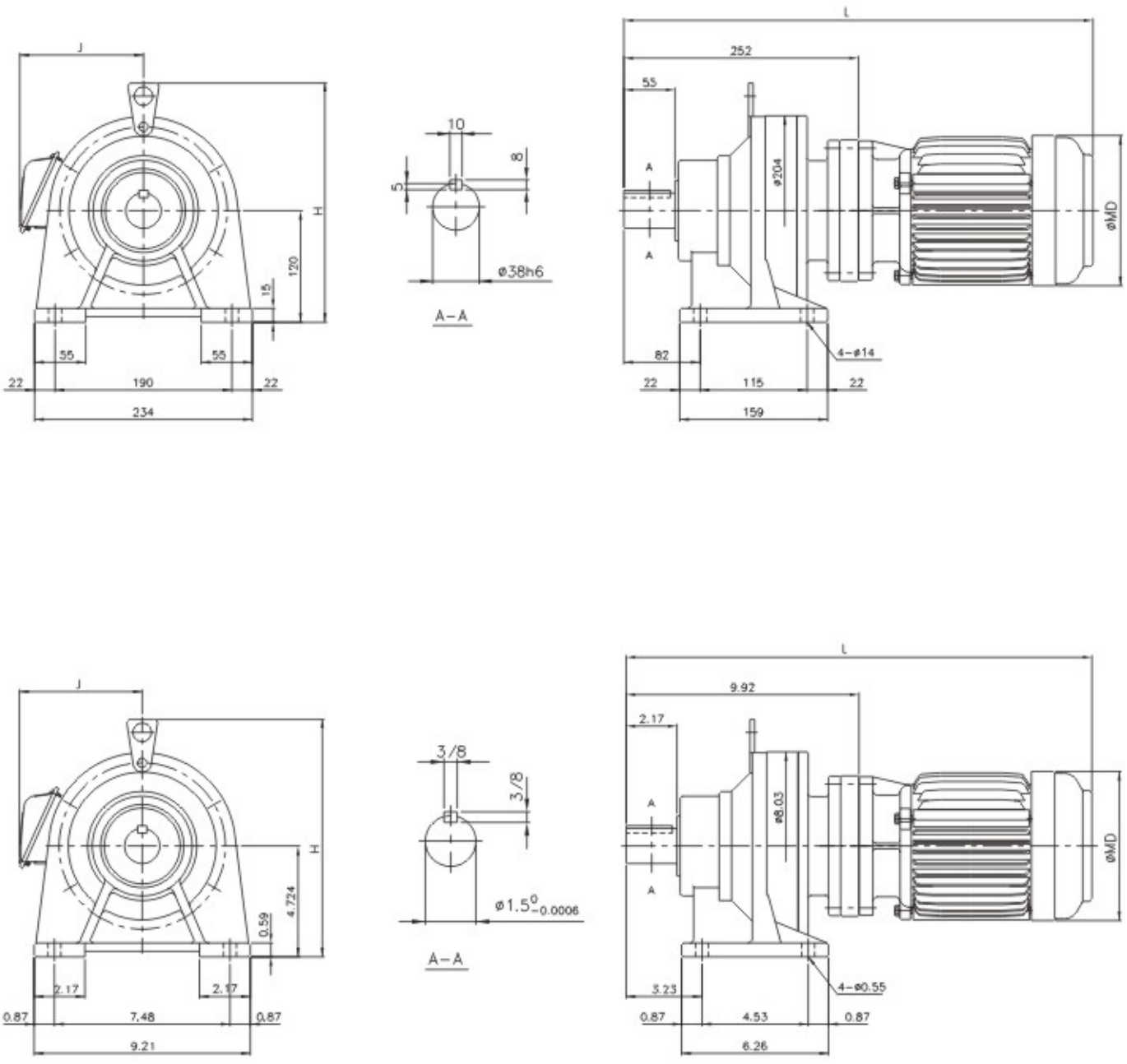

Motor			TRANSCYKO Model No.	Metric ( mm, kg )					Inches ( in.lbs )				
KW	HP	POLE		L	J	DM	H	Weight	L	J	DM	H	Weight
0.2	1/4	4	THM02-611/09	471	121	144	257	40	18.54	4.76	5.67	10.12	88.0
0.4	1/2	4	THM05-611/09	492	132	162	257	43	19.37	5.20	6.38	10.12	94.6
0.75	1	4	THM1-611/09	491	137	177	257	45	19.33	5.39	6.97	10.12	99.0



THHM-613/08

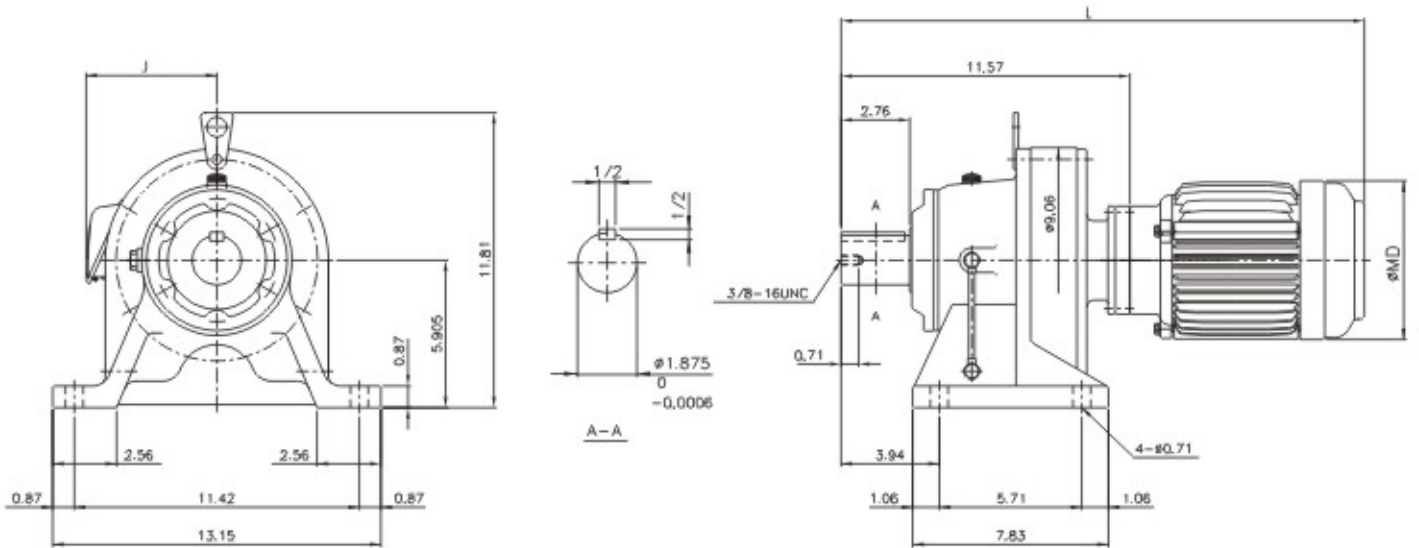
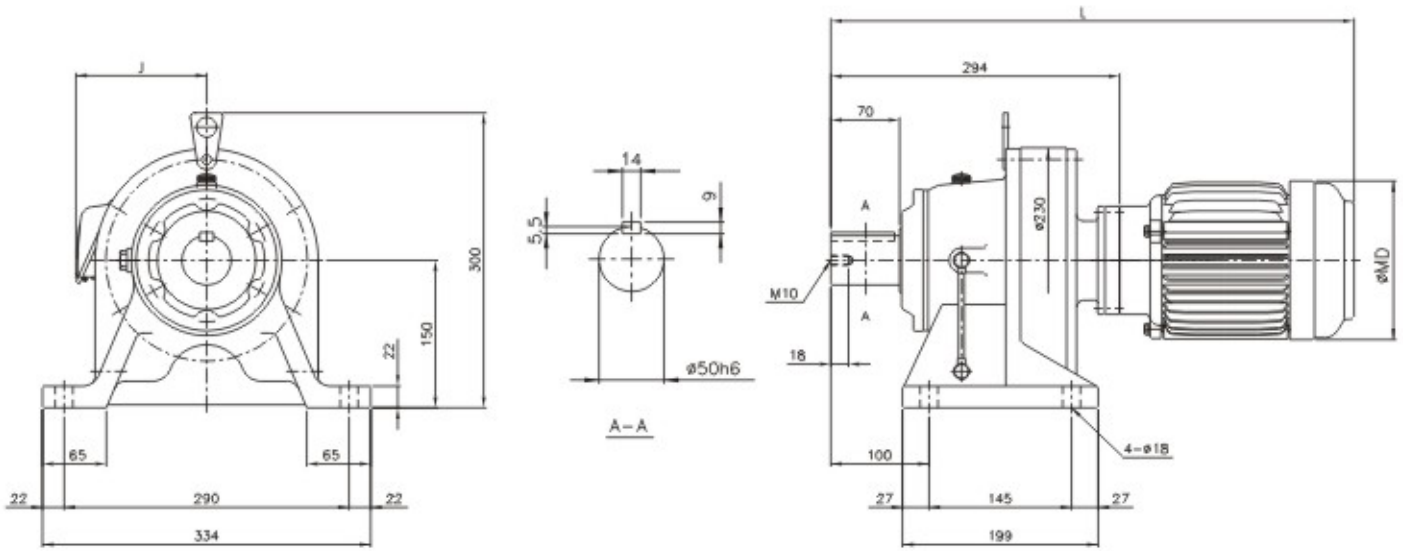

Motor			TRANSCYKO Model No.	Metric ( mm, kg )					Inches ( in.lbs )				
KW	HP	POLE		L	J	DM	H	Weight	L	J	DM	H	Weight
0.2	1/4	4	THHM02-613/08	513	121	144		49	20.20	4.76	5.67		107.8
0.4	1/2	4	THHM05-613/08	534	132	162		54	21.02	5.20	6.38		118.8

THHM-613/09

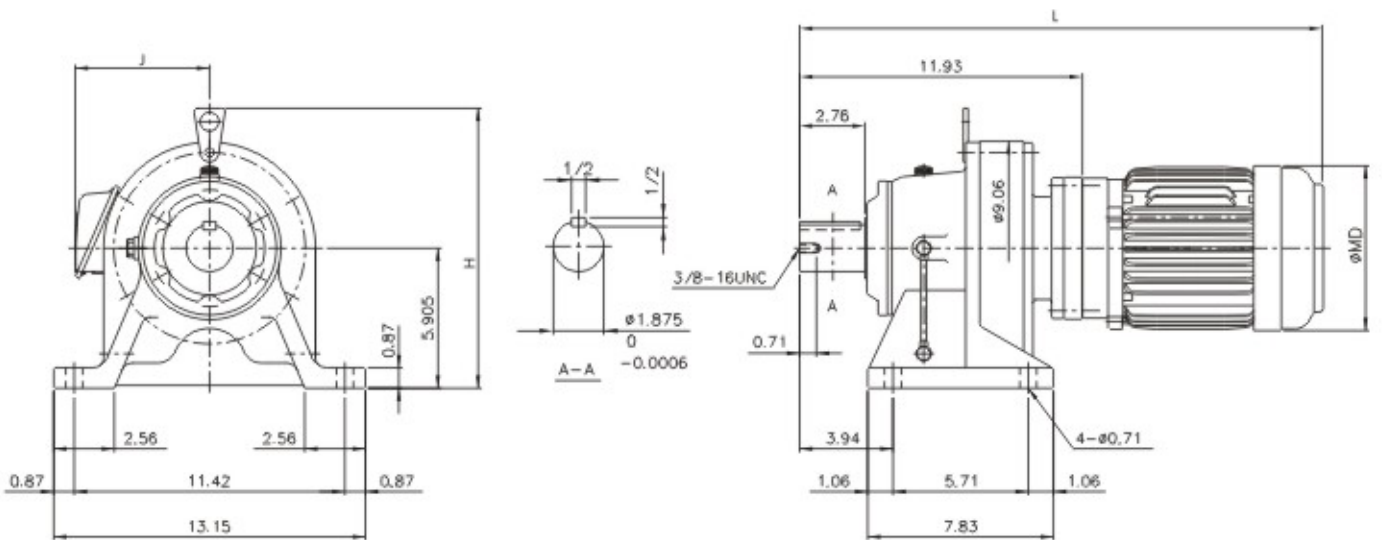
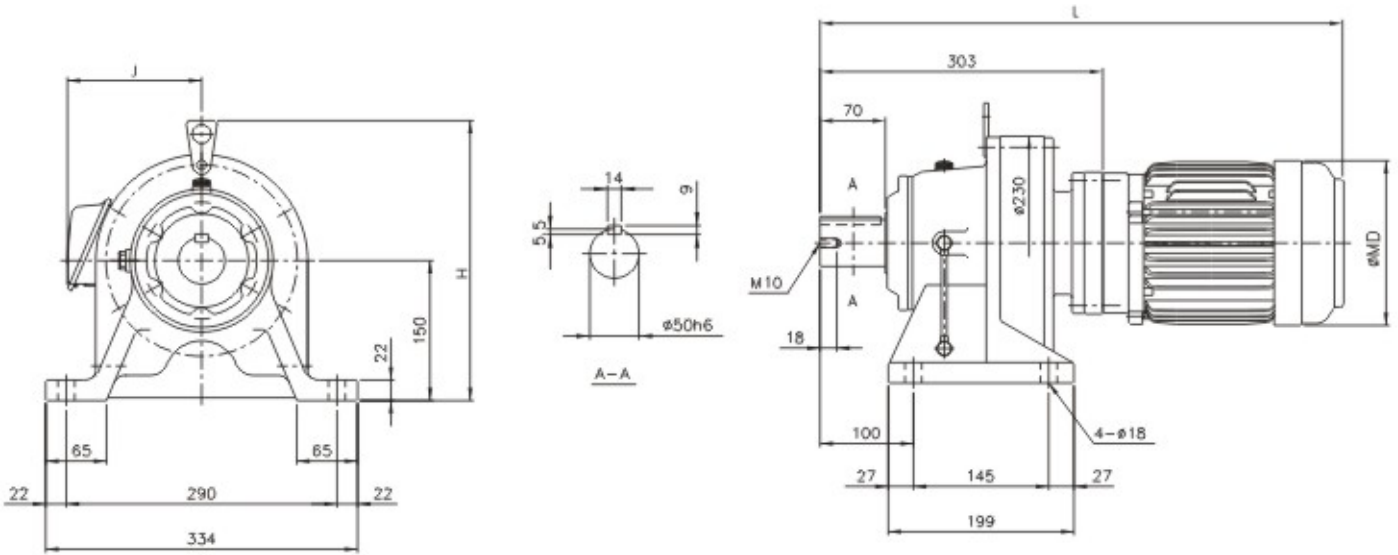

Motor			TRANSCYKO Model No.	Metric ( mm, kg )					Inches ( in.lbs )				
KW	HP	POLE		L	J	DM	H	Weight	L	J	DM	H	Weight
0.2	1/4	4	THHM02-613/09	522	121	144	300	53	20.55	4.76	5.67	11.81	116.6
0.4	1/2	4	THHM05-613/09	534	132	162	300	57	21.38	5.20	6.38	11.81	125.4
0.75	1	4	THHM1-613/09	542	137	177	300	60	21.34	5.39	6.97	11.81	132.0



THHM-613/10

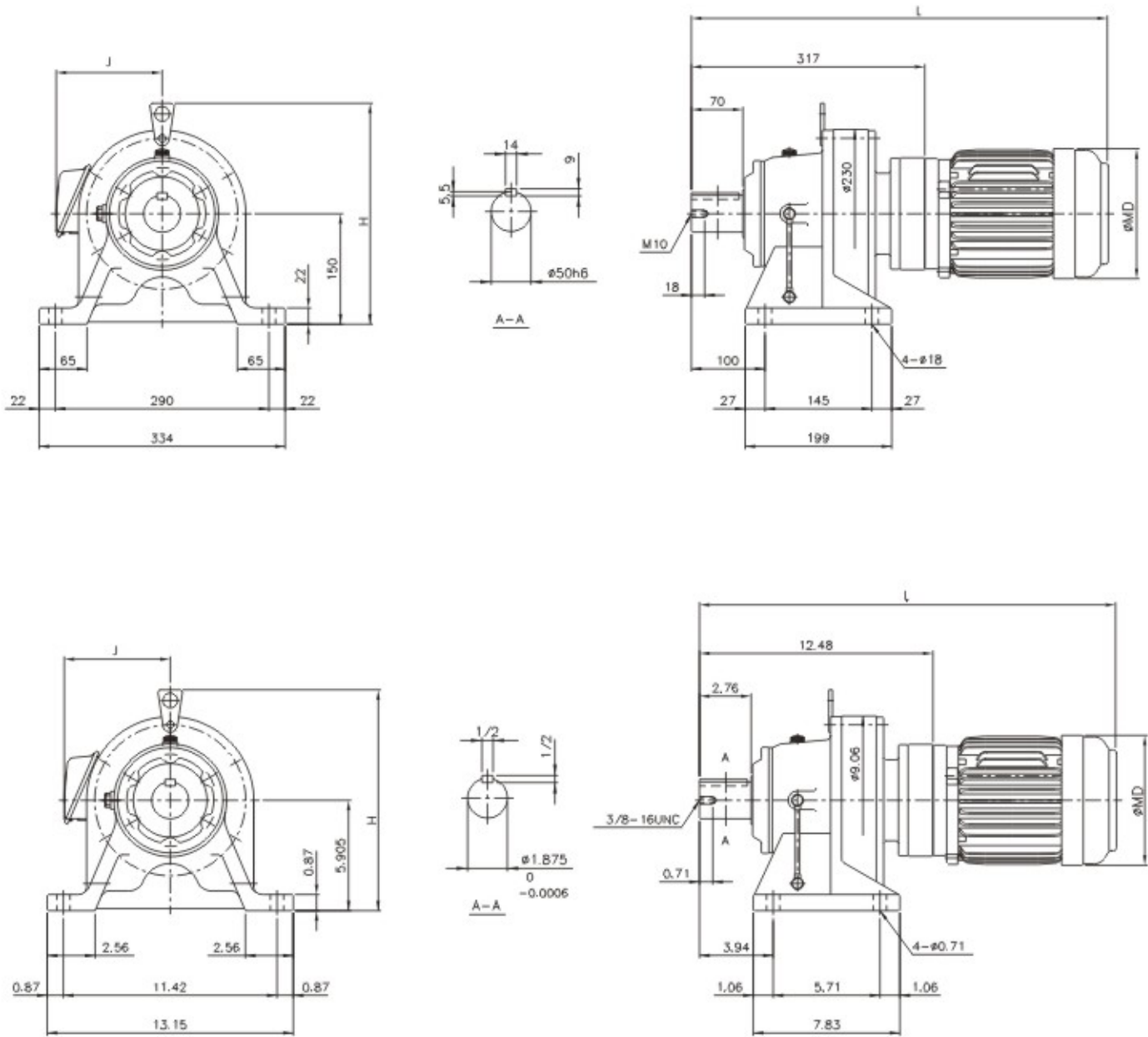

Motor			TRANSCYKO Model No.	Metric ( mm, kg )					Inches ( in.lbs )				
KW	HP	POLE		L	J	DM	H	Weight	L	J	DM	H	Weight
0.4	1/4	4	THHM05-613/10	557	132	162	300	59	21.93	5.20	6.38	11.81	129.8
0.75	1/2	4	THHM1-613/10	556	137	177	300	61	21.89	5.39	6.97	11.81	134.2
1.5	2	4	THHM2-613/10	593	150	200	300	70	23.35	5.91	7.87	11.81	154.0
2.2		4	THHM3-613/10	619	173	219	300	82	24.37	6.81	8.62	11.81	180.4

THHM-614/08

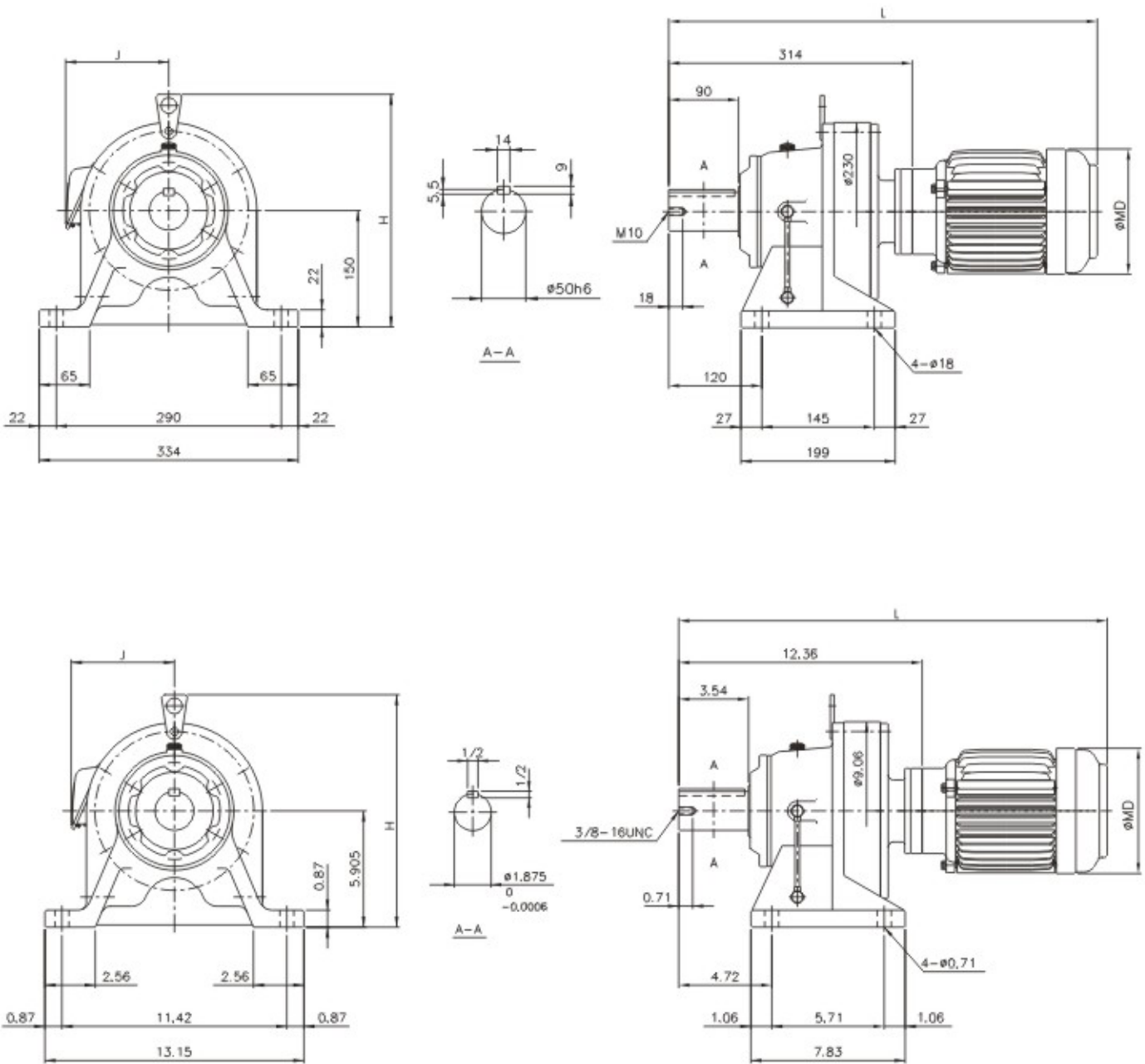

Motor			TRANSCYKO Model No.	Metric ( mm, kg )					Inches ( in.lbs )				
KW	HP	POLE		L	J	DM	H	Weight	L	J	DM	H	Weight
0.2	1/4	4	THHM02-614/08	533	121	144		50	20.98	4.76	5.67		110.0
0.4	1/2	4	THHM05-614/08	554	132	162		54	21.81	5.20	6.38		118.8



THHM-614/09

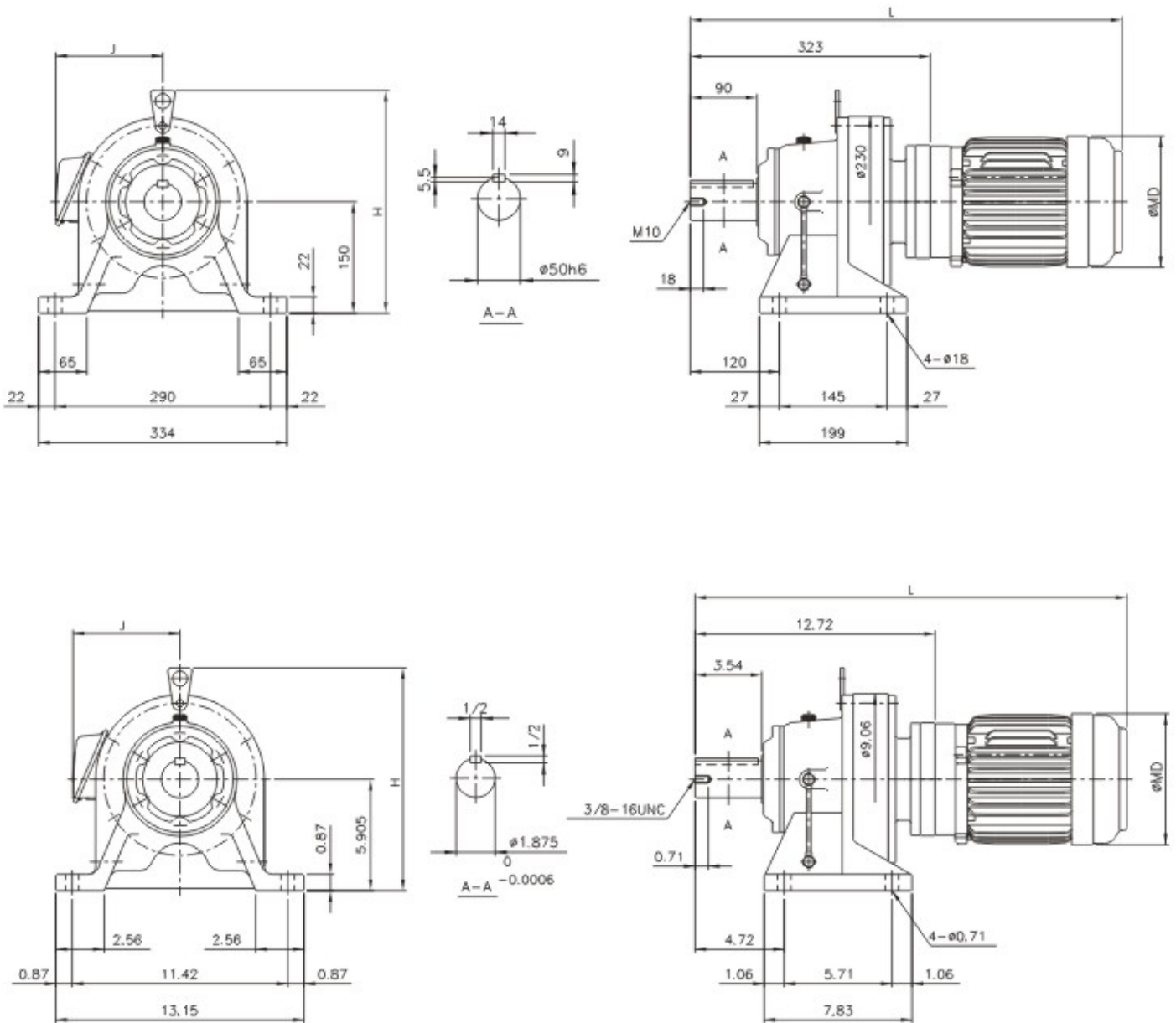

Motor			TRANSCYKO Model No.	Metric ( mm, kg )					Inches ( in.lbs )				
KW	HP	POLE		L	J	DM	H	Weight	L	J	DM	H	Weight
0.2	1/4	4	THHM02-614/09	542	121	144	300	53	21.34	4.76	5.67	11.81	116.6
0.4	1/2	4	THHM05-614/09	563	132	162	300	57	22.17	5.20	6.38	11.81	125.4
0.75	1	4	THHM1-614/09	562	137	177	300	60	22.13	5.39	6.97	11.81	132.0

THHM-614/10

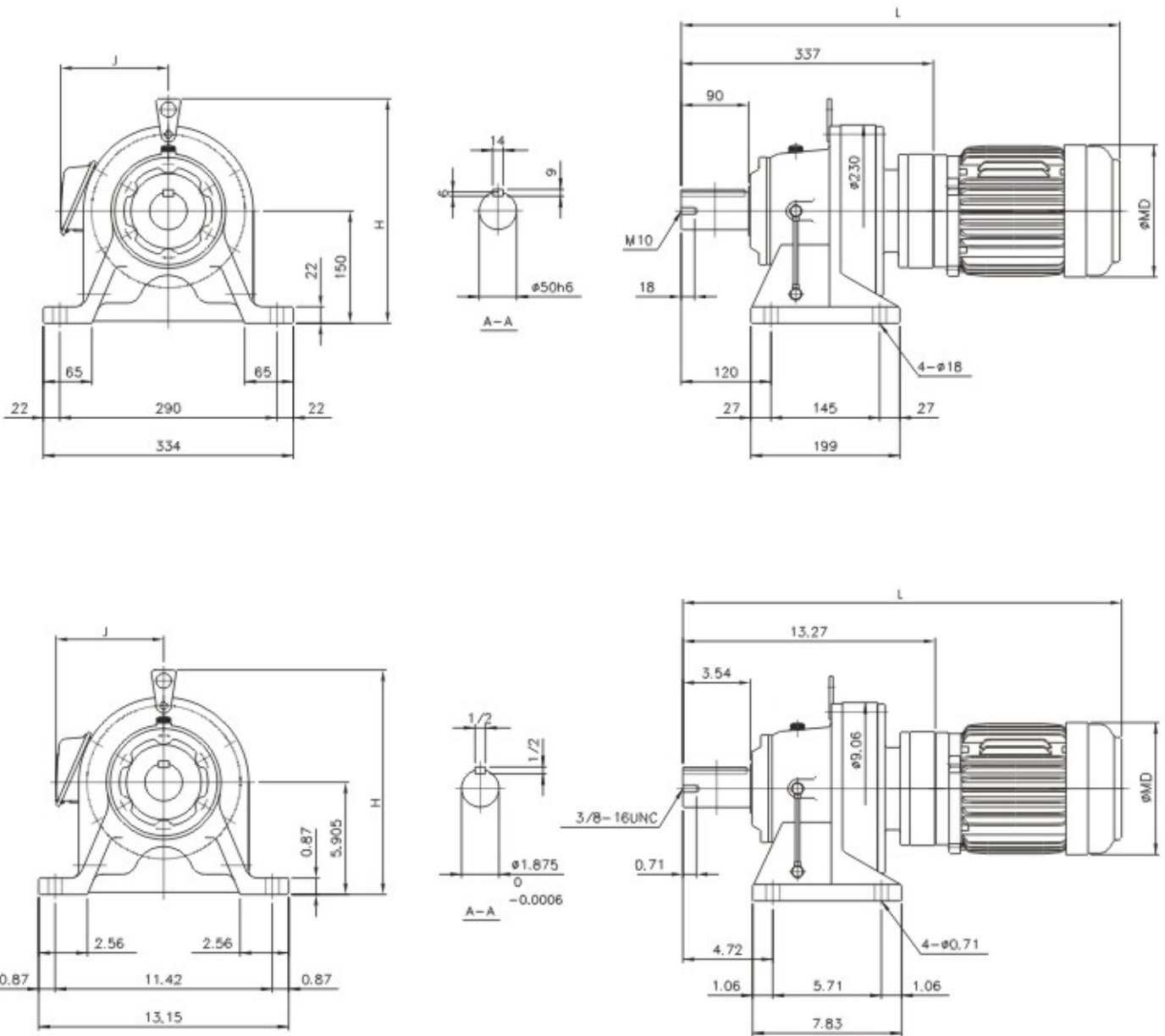

Motor			TRANSCYKO Model No.	Metric ( mm, kg )					Inches ( in.lbs )				
KW	HP	POLE		L	J	DM	H	Weight	L	J	DM	H	Weight
0.4	1/2	4	THHM05-614/10	577	132	162	300	59	22.72	5.20	6.38	11.81	129.8
0.75	1	4	THHM1-614/10	576	137	177	300	61	22.68	5.39	6.97	11.81	134.2
1.5	2	4	THHM2-614/10	613	150	200	300	70	21.13	5.91	7.87	11.81	154.0
2.2	3	4	THHM3-614/10	640	173	219	300	82	25.20	6.81	8.62	11.81	180.4



THHM-616/09

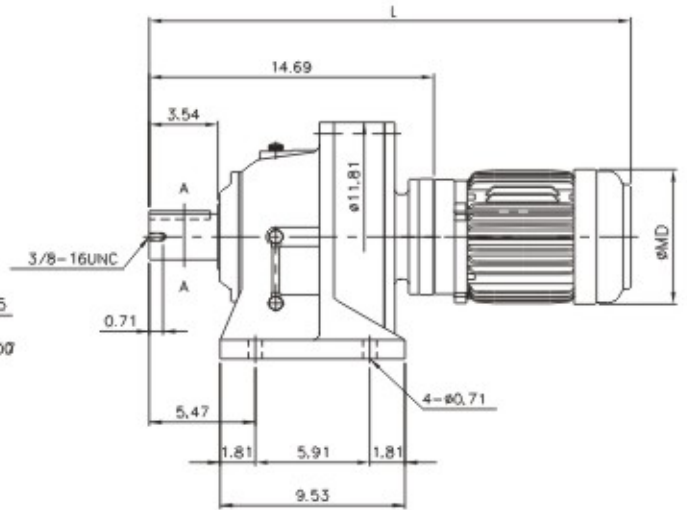
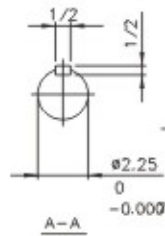
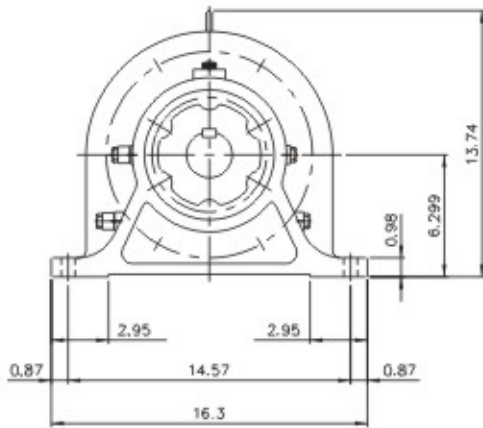
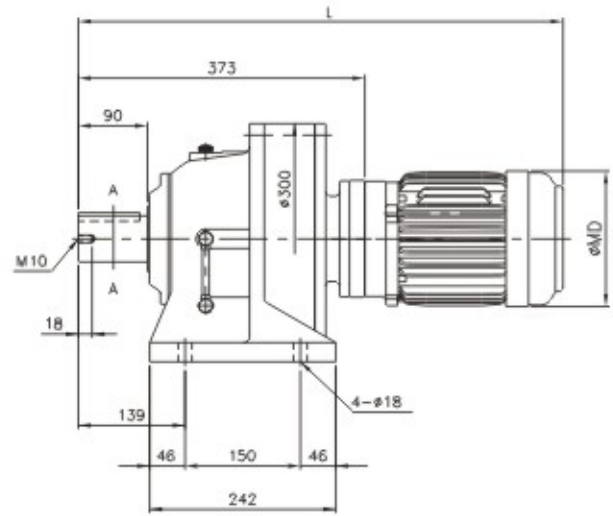
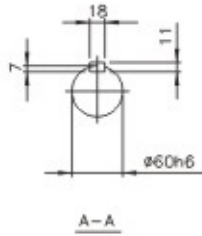
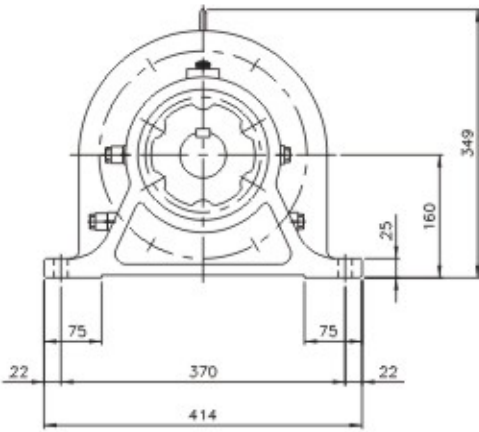

Motor			TRANSCYKO Model No.	Metric (mm, kg)					Inches (in.lbs)				
KW	HP	POLE		L	J	DM	H	Weight	L	J	DM	H	Weight
0.2	1/4	4	THHM02-616/09	592	121	144		94	23.31	4.76	5.67		206.8
0.4	1/2	4	THHM05-616/09	613	132	162		98	24.13	5.20	6.38		215.6
0.75	1	4	THHM1-616/09	631	137	177		100	24.09	5.39	6.97		220.0

THHM-616/10

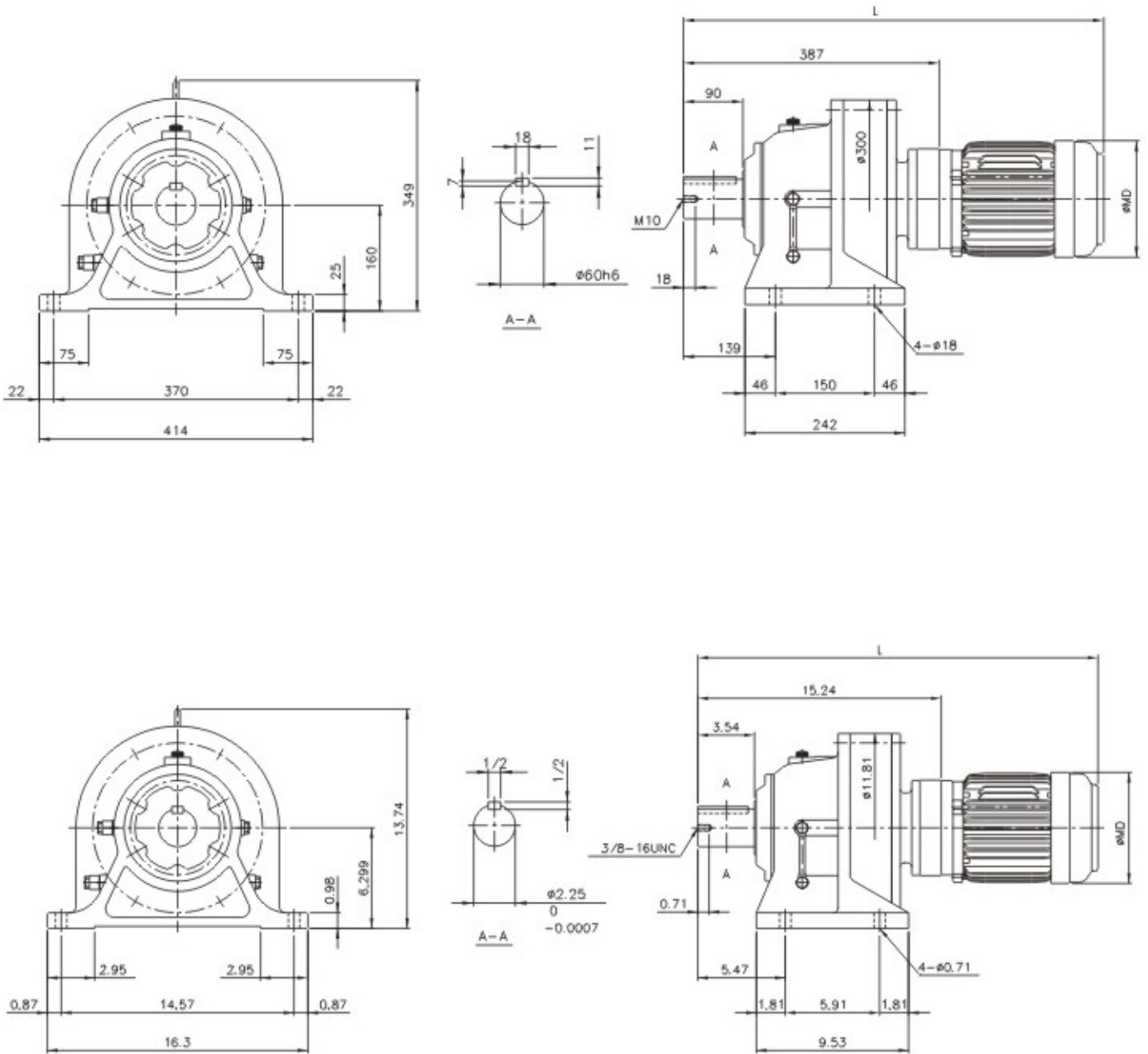

Motor			TRANSCYKO Model No.	Metric ( mm, kg )					Inches ( in.lbs )				
KW	HP	POLE		L	J	DM	H	Weight	L	J	DM	H	Weight
0.4	1/2	4	THHM05-616/10	627	132	162		99	24.69	5.20	6.38		217.8
0.75	1	4	THHM1-616/10	626	137	177		102	24.65	5.39	6.97		224.4
1.5	2	4	THHM2-616/10	663	150	200		111	26.10	5.91	7.87		224.2
2.2	3	4	THHM3-616/10	690	173	219		123	27.17	6.81	8.62		270.6



THHM-616/11

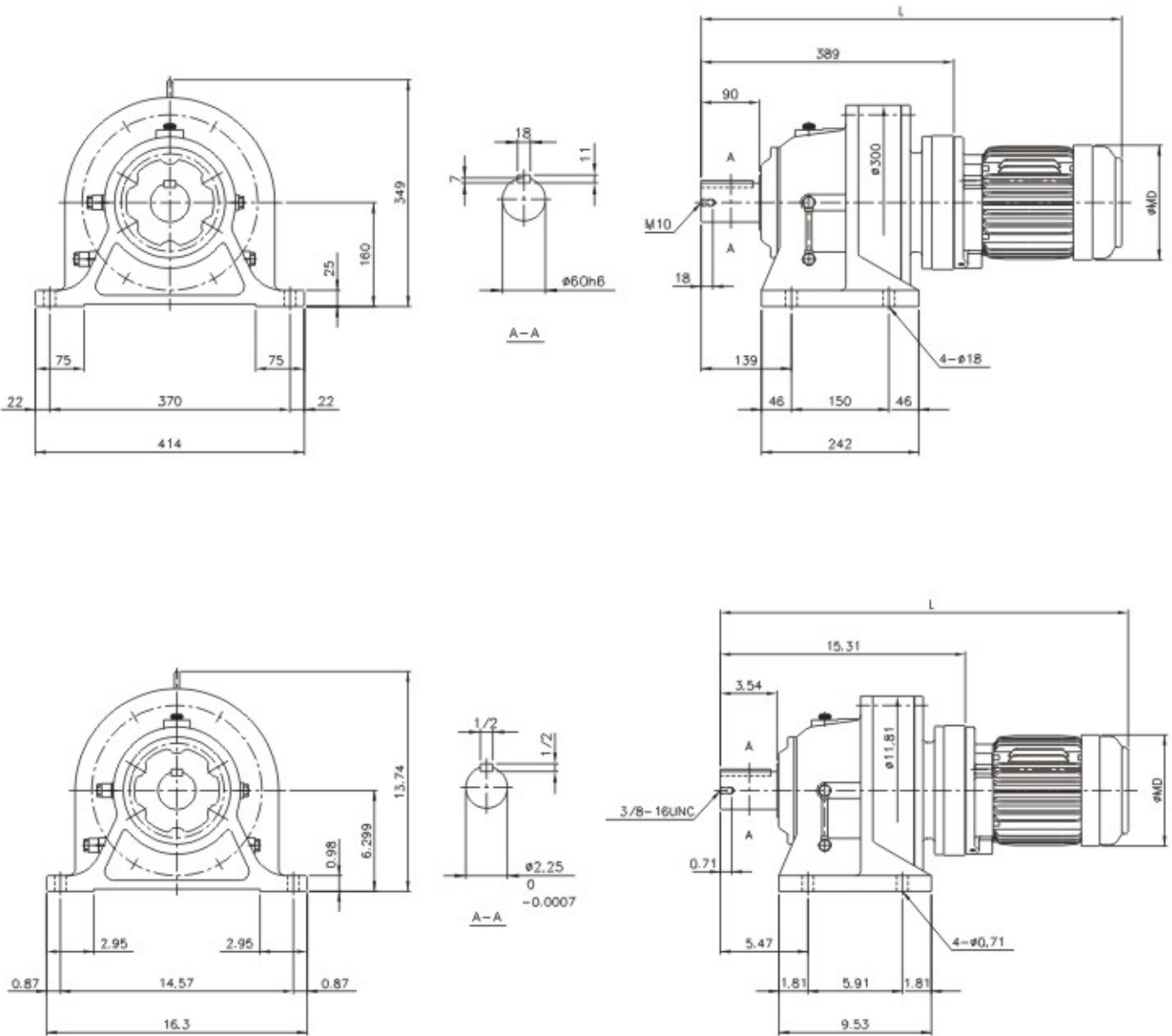

Motor			TRANSCYKO Model No.	Metric ( mm, kg )					Inches ( in.lbs )				
KW	HP	POLE		L	J	DM	H	Weight	L	J	DM	H	Weight
0.4	1/2	4	THHM05-616/11	623	132	162		99	24.72	5.20	6.38		217.8
0.75	1	4	THHM1-616/11	637	137	177		104	25.08	5.39	6.97		228.8
1.5	2	4	THHM2-616/11	674	156	200		115	26.54	6.14	7.87		253.0
2.2	3	4	THHM3-616/11	700	173	219		130	27.56	6.81	8.62		286.0
3.7	5	4	THHM5-616/11	716	188	238		139	28.19	7.40	9.37		305.8

THHM-617/09

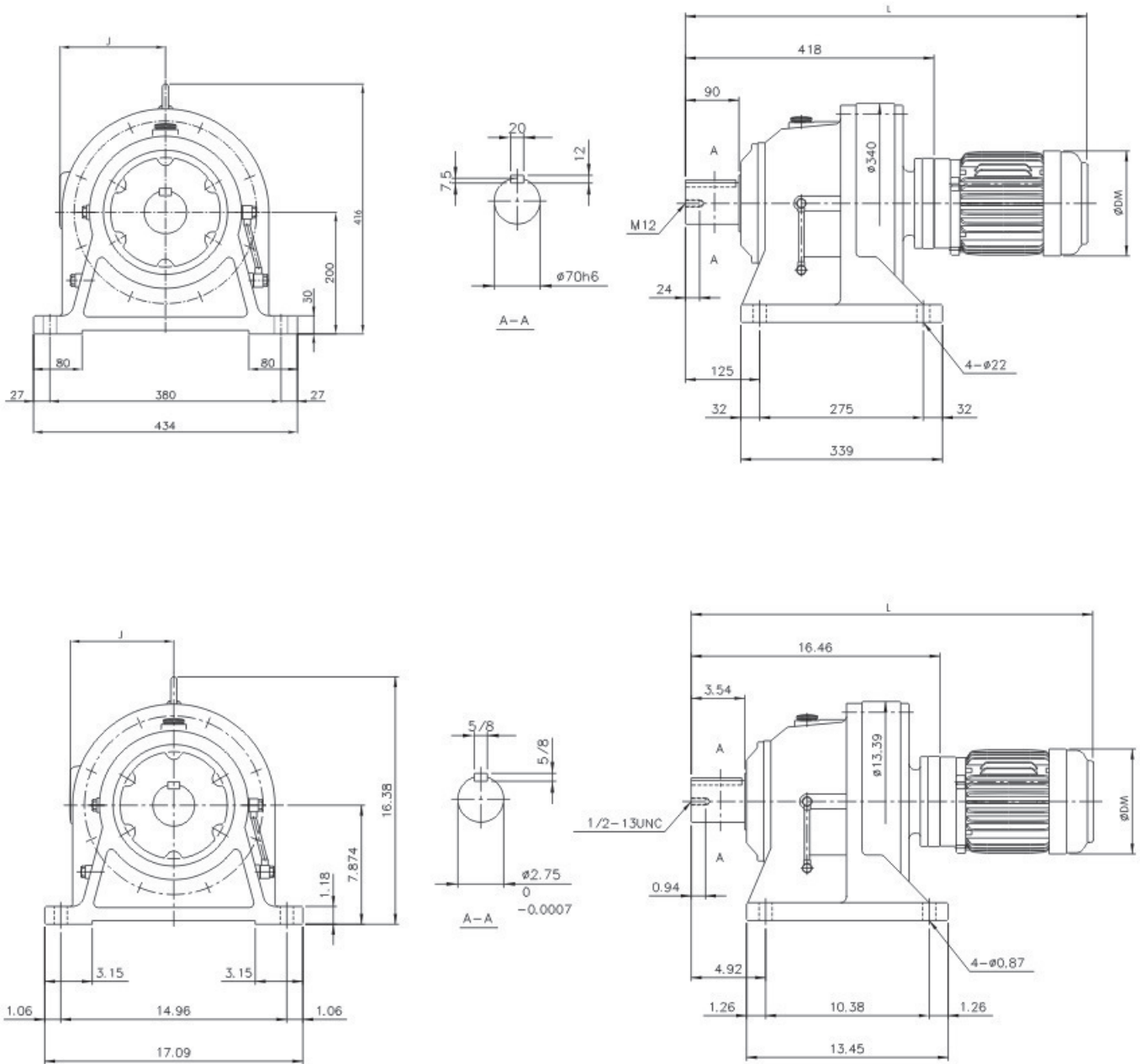

Motor			TRANSCYKO Model No.	Metric ( mm, kg )					Inches ( in.lbs )				
KW	HP	POLE		L	J	DM	H	Weight	L	J	DM	H	Weight
0.2	1/4	4	THHM02-617/09	637	121	144		130	25.08	4.76	5.67		286.0
0.4	1/2	4	THHM05-617/09	658	132	162		132	25.91	5.20	6.38		290.4
0.75	1	4	THHM1-617/09	657	137	177		136	25.87	5.39	6.97		299.2



THHM-617/10

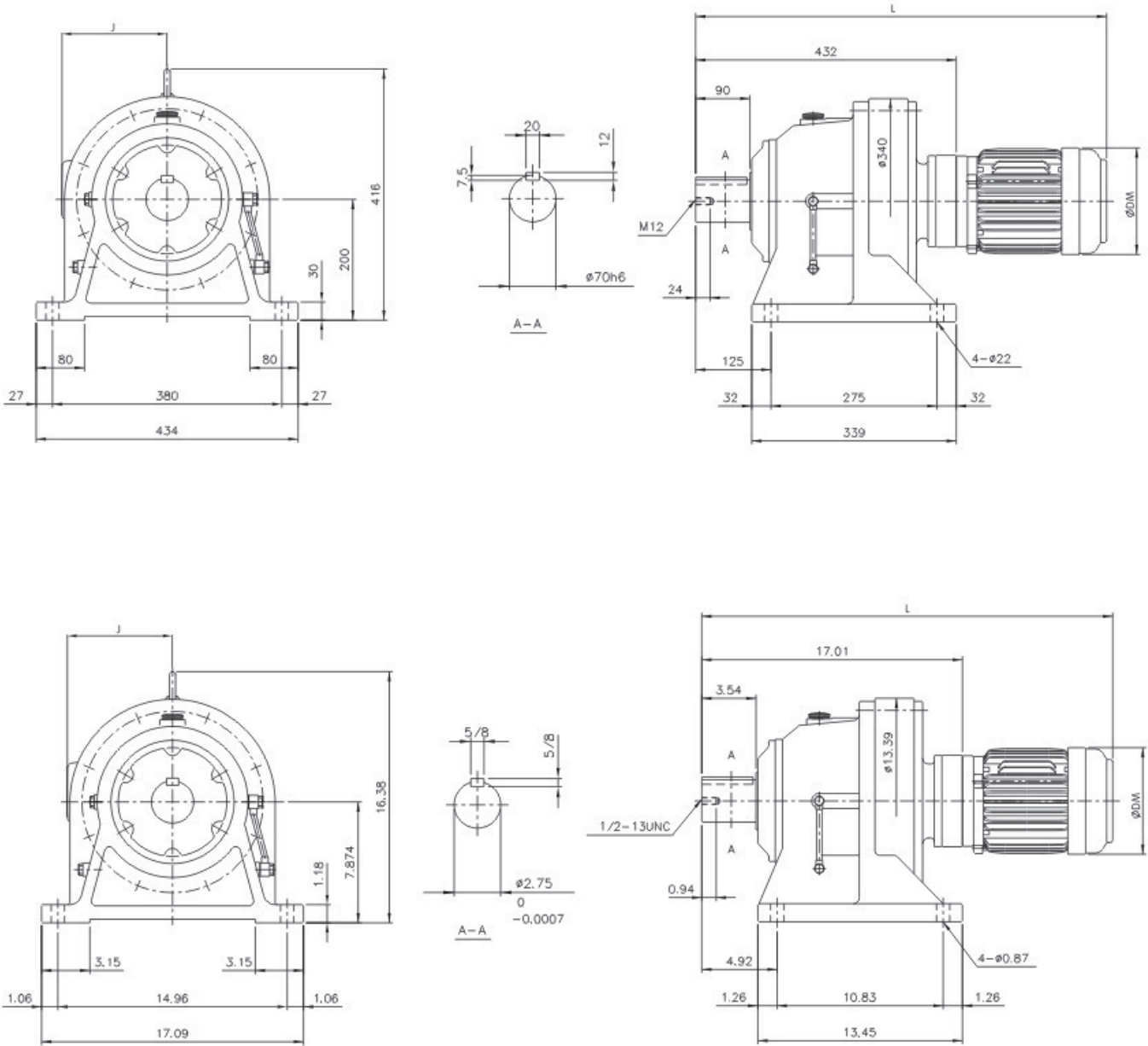

Motor			TRANSCYKO Model No.	Metric ( mm, kg )					Inches ( in,lbs )				
KW	HP	POLE		L	J	DM	H	Weight	L	J	DM	H	Weight
0.4	1/2	4	THHM05-617/10	672	132	162		134	26.46	5.20	6.38		294.8
0.75	1	4	THHM1-617/10	671	137	177		138	26.42	5.39	6.97		303.6
1.5	2	4	THHM2-617/10	708	150	200		147	27.87	5.91	7.87		323.4
2.2	3	4	THHM3-617/10	735	173	219		159	28.94	6.81	8.62		349.8

# THHM-617/11

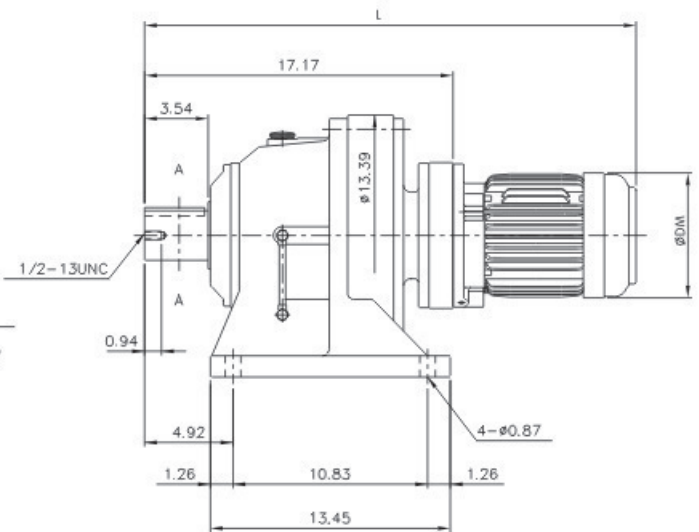
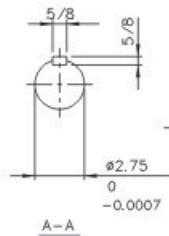
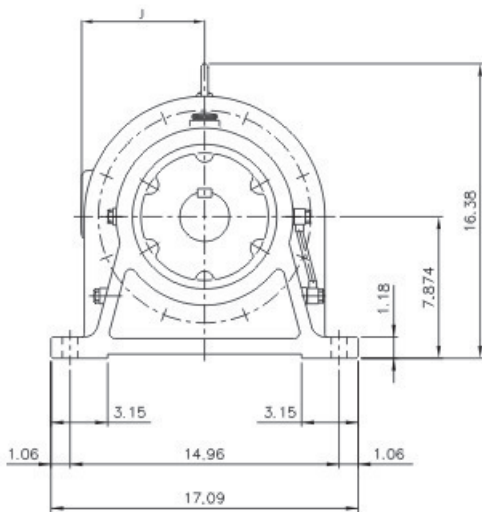
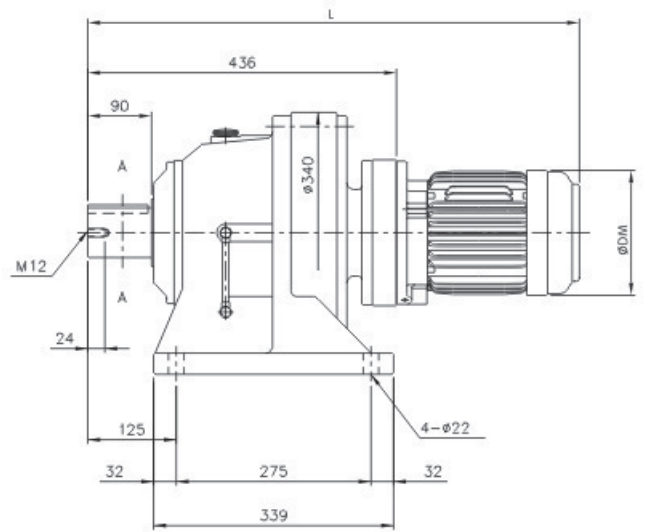
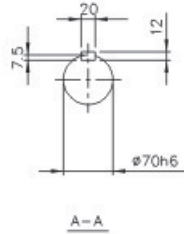
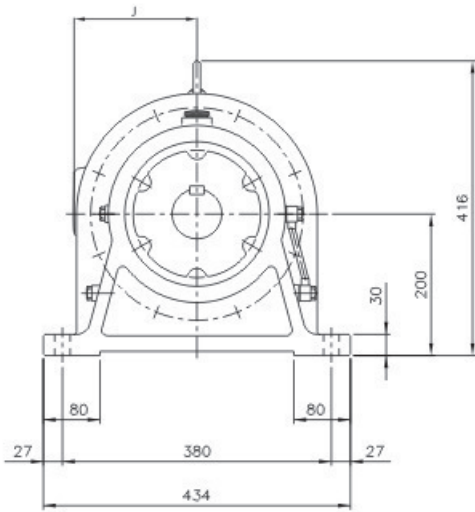

Motor			TRANSCYKO Model No.	Metric ( mm, kg )					Inches ( in.lbs )				
KW	HP	POLE		L	J	DM	H	Weight	L	J	DM	H	Weight
0.4	1/2	4	THHM05-617/11	675	132	162	135	135	26.57	5.20	6.38		297.0
0.75	1	4	THHM1-617/11	684	137	177	141	141	26.93	5.39	6.97		310.2
1.5	2	4	THHM2-617/11	721	150	200	152	152	28.39	5.91	7.87		334.4
2.2	3	4	THHM3-617/11	747	173	219	164	164	29.41	6.81	8.62		360.8
3.7	5	4	THHM5-617/11	763	188	238	173	173	30.04	7.40	9.37		380.6



**THHM-618/10**

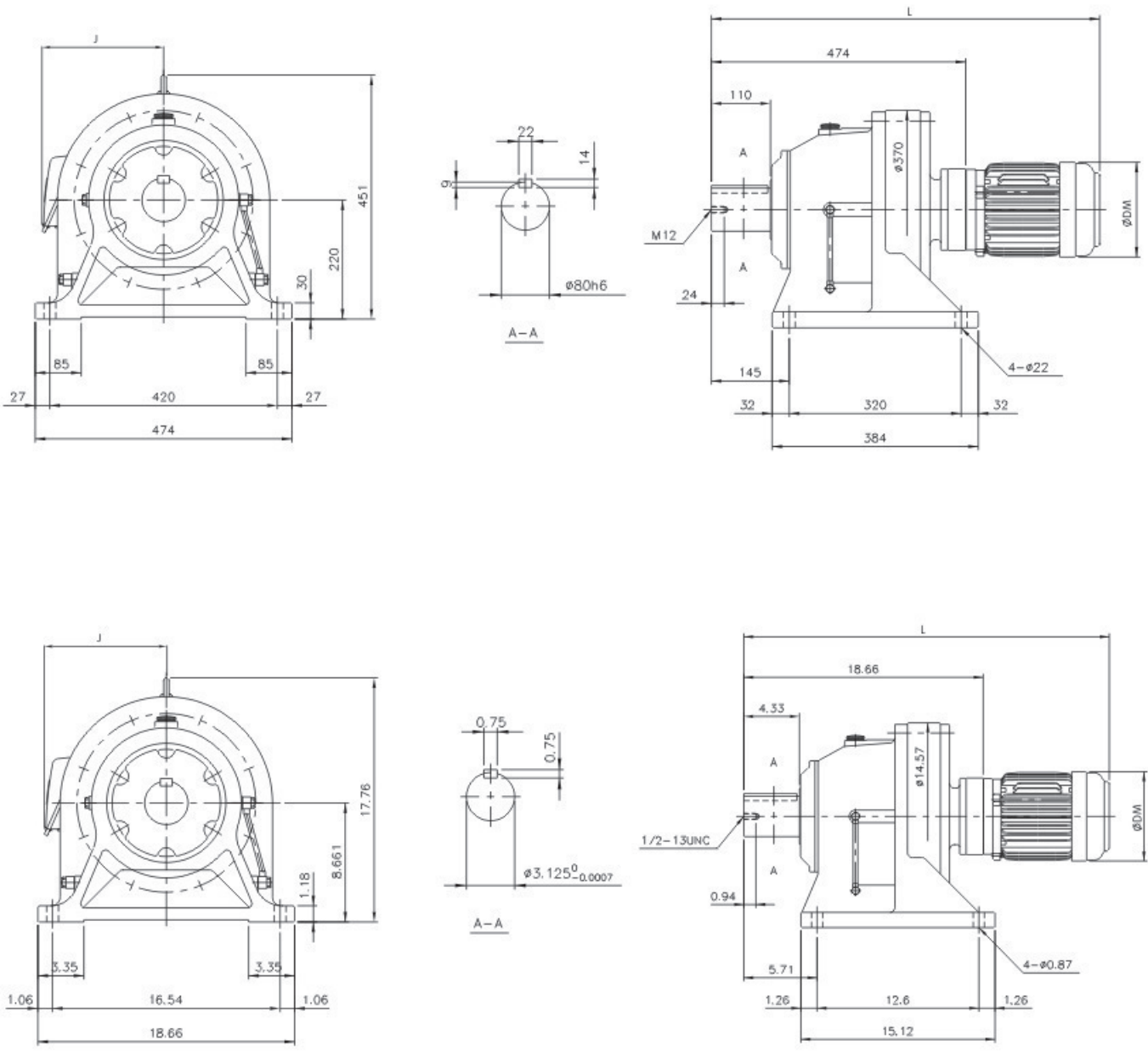

Motor			TRANSCYKO Model No.	Metric ( mm, kg )					Inches ( in.lbs )				
KW	HP	POLE		L	J	DM	H	Weight	L	J	DM	H	Weight
0.4	1/2	4	THHM05-618/10	714	132	162		176	28.11	5.20	6.38		387.2
0.75	1	4	THHM1-618/10	713	137	177		180	28.07	5.39	6.97		396.0
1.5	2	4	THHM2-618/10	750	150	200		189	29.53	5.91	7.87		415.8
2.2	3	4	THHM3-618/10	799	173	219		201	31.46	6.81	8.62		442.2

# THHM-618/13

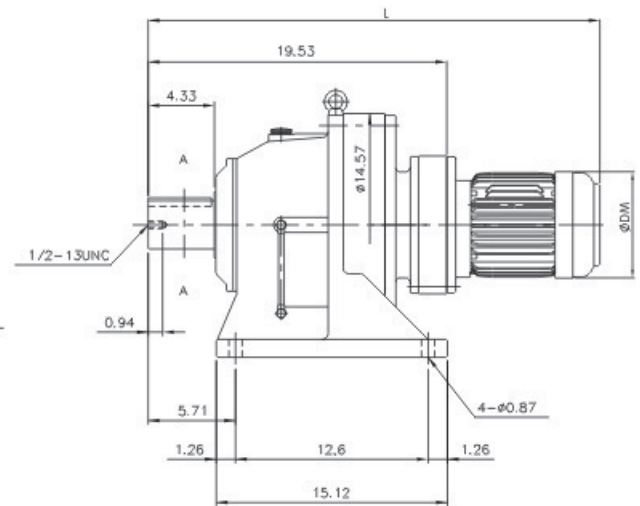
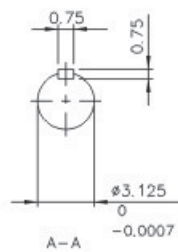
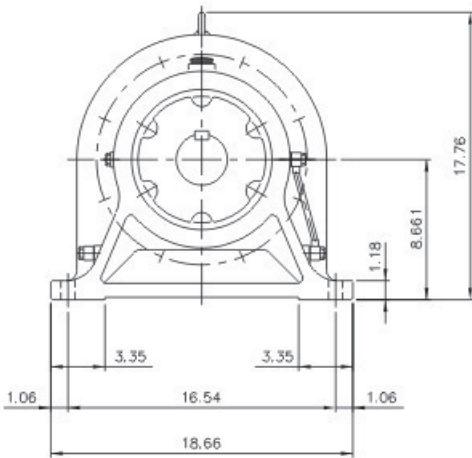
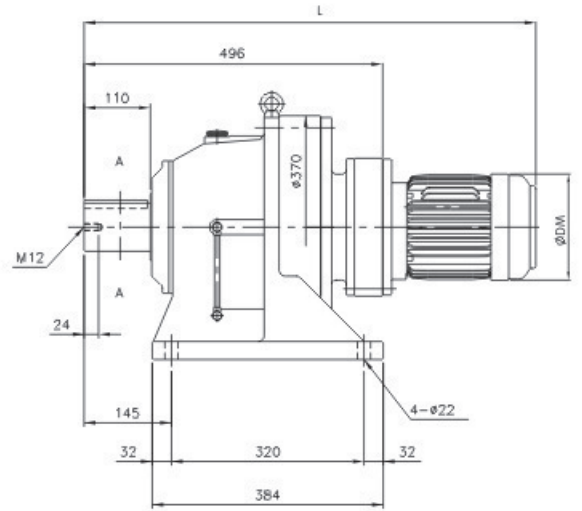
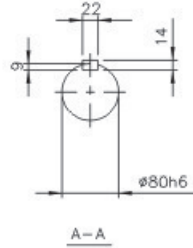
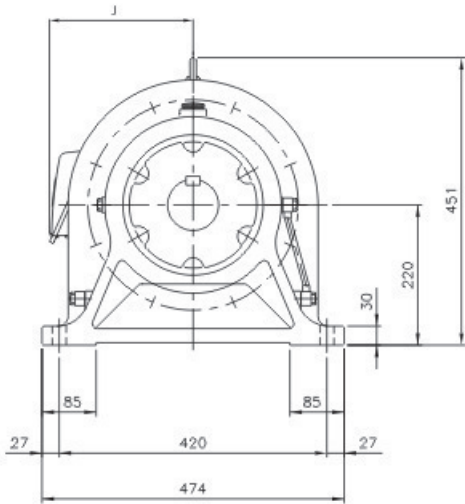

Motor			TRANSCYKO Model No.	Metric ( mm, kg )					Inches ( in.lbs )				
KW	HP	POLE		L	J	DM	H	Weight	L	J	DM	H	Weight
0.75	1	4	THHM1-618/13	740	143	177		195	29.13	5.63	6.97		429.0
1.5	2	4	THHM2-618/13	780	150	200		207	30.71	5.91	7.87		455.4
2.2	3	4	THHM3-618/13	807	143	219		219	31.77	6.81	8.62		481.8
3.7	5	4	THHM5-618/13	826	187	238		224	32.52	7.36	9.37		492.8
5.5	7.5	4	THHM8-618/13	870	218	273		230	34.25	8.58	10.75		506.0
7.5	10	4	THHM10-618/13	908	223	273		236	35.75	8.78	10.75		519.2



THHM-619/11

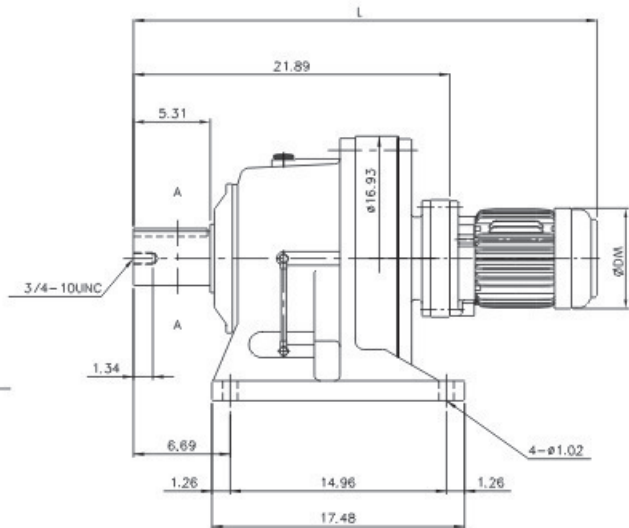
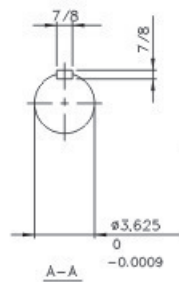
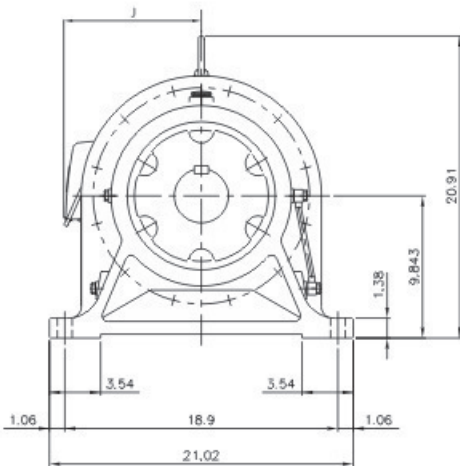
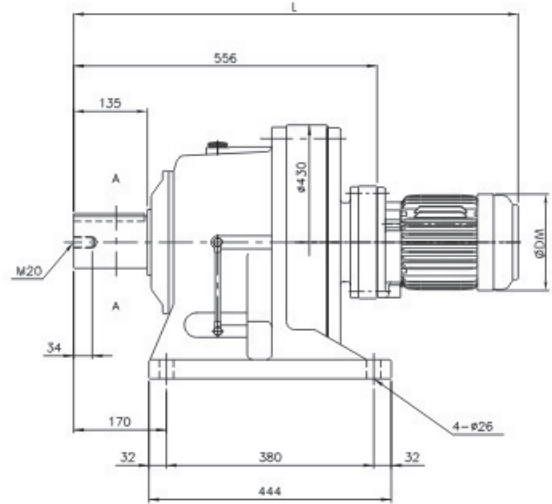
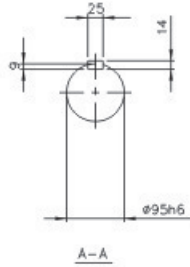
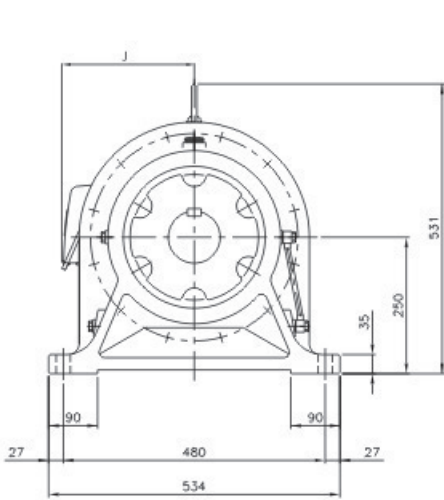

Motor			TRANSCYKO Model No.	Metric ( mm, kg )					Inches ( in.lbs )				
KW	HP	POLE		L	J	DM	H	Weight	L	J	DM	H	Weight
0.4	1/2	4	THHM05-619/11	795	132	162		245	31.30	5.20	6.38		539.0
0.75	1	4	THHM1-619/11	804	137	177		256	31.65	5.39	6.97		563.2
1.5	2	4	THHM2-619/11	841	150	200		265	33.11	6.14	7.87		583.0
2.2	3	4	THHM3-619/11	867	173	219		277	34.13	6.81	8.62		609.4
3.7	5	4	THHM5-619/11	883	188	238		286	34.76	7.40	9.37		629.2

# THHM-619/13

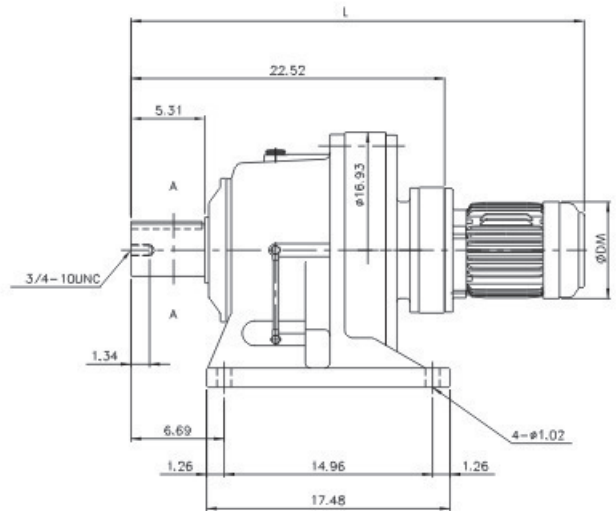
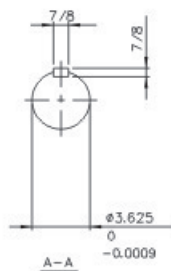
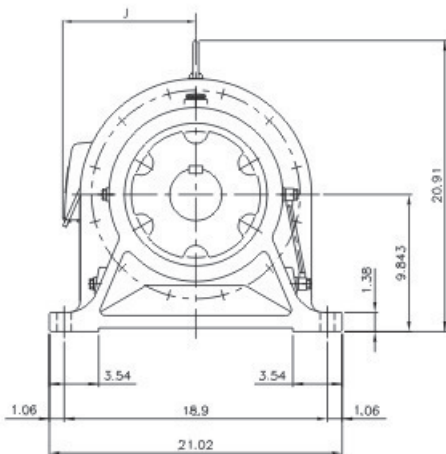
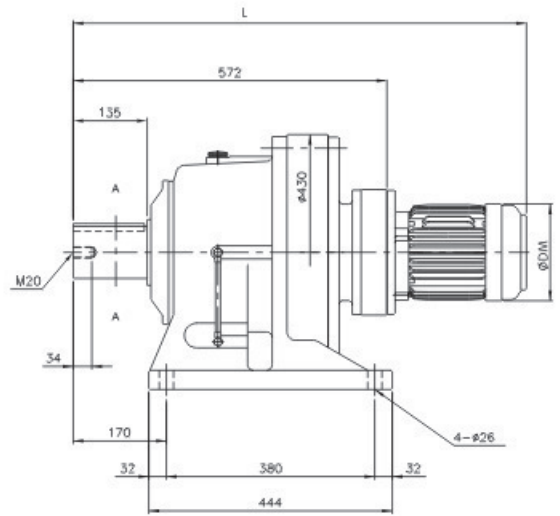
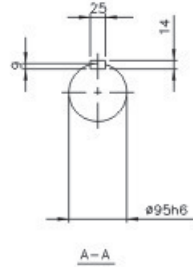
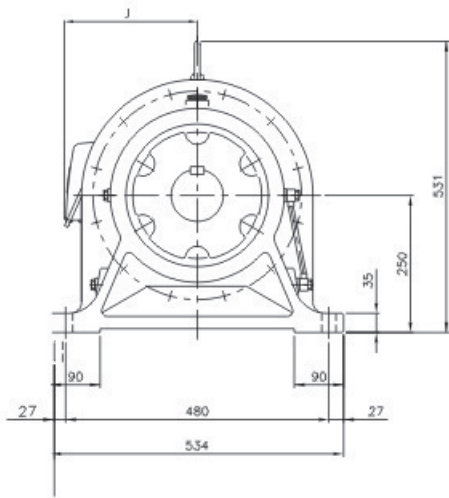

Motor			TRANSCYKO Model No.	Metric ( mm, kg )					Inches ( in.lbs )				
KW	HP	POLE		L	J	DM	H	Weight	L	J	DM	H	Weight
0.75	1	4	THHM1-619/13	816	143	177		263	32.13	5.63	6.97		578.6
1.5	2	4	THHM2-619/13	856	150	200		275	33.70	5.91	7.87		605.0
2.2	3	4	THHM3-619/13	883	173	219		286	34.76	6.81	8.62		629.2
3.7	5	4	THHM5-619/13	902	187	238		295	35.51	7.36	9.37		649.0
5.5	7.5	4	THHM8-619/13	946	218	273		301	37.24	8.58	10.75		662.2
7.5	10	4	THHM10-619/13	984	223	273		313	38.74	8.78	10.75		688.6



# THHM-620/11

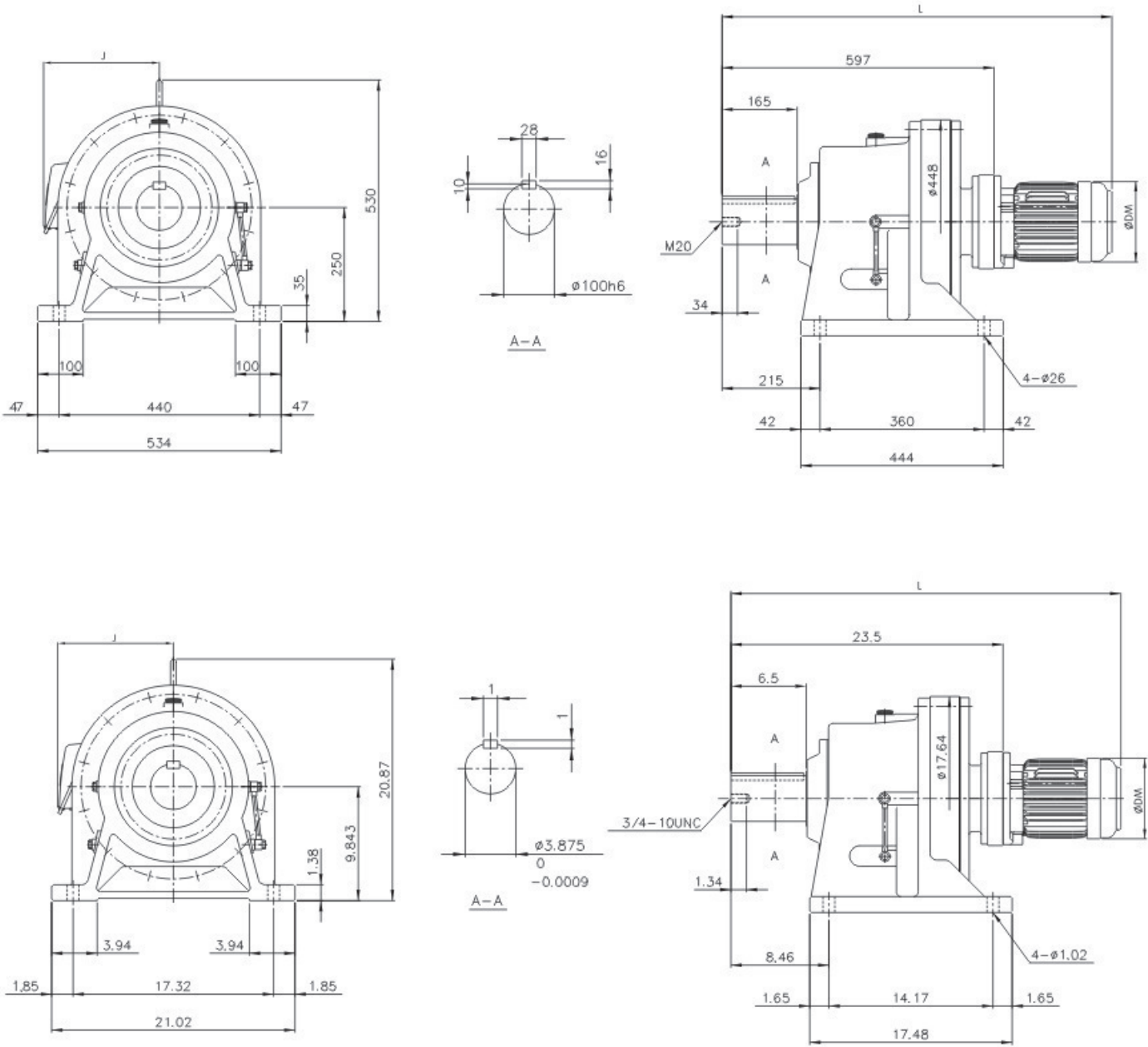

Motor			TRANSCYKO Model No.	Metric ( mm, kg )					Inches ( in.lbs )				
KW	HP	POLE		L	J	DM	H	Weight	L	J	DM	H	Weight
0.4	1/2	4	THHM05-620/11	836	132	162		269	32.91	5.20	6.38		591.8
0.75	1	4	THHM1-620/11	845	137	177		277	33.27	5.39	6.97		609.4
1.5	2	4	THHM2-620/11	882	156	200		284	34.72	6.14	7.87		624.8
2.2	3	4	THHM3-620/11	908	173	219		290	35.75	6.81	8.62		638.0
3.7	5	4	THHM5-620/11	924	188	238		296	36.38	7.40	9.37		651.2

# THHM-620/13

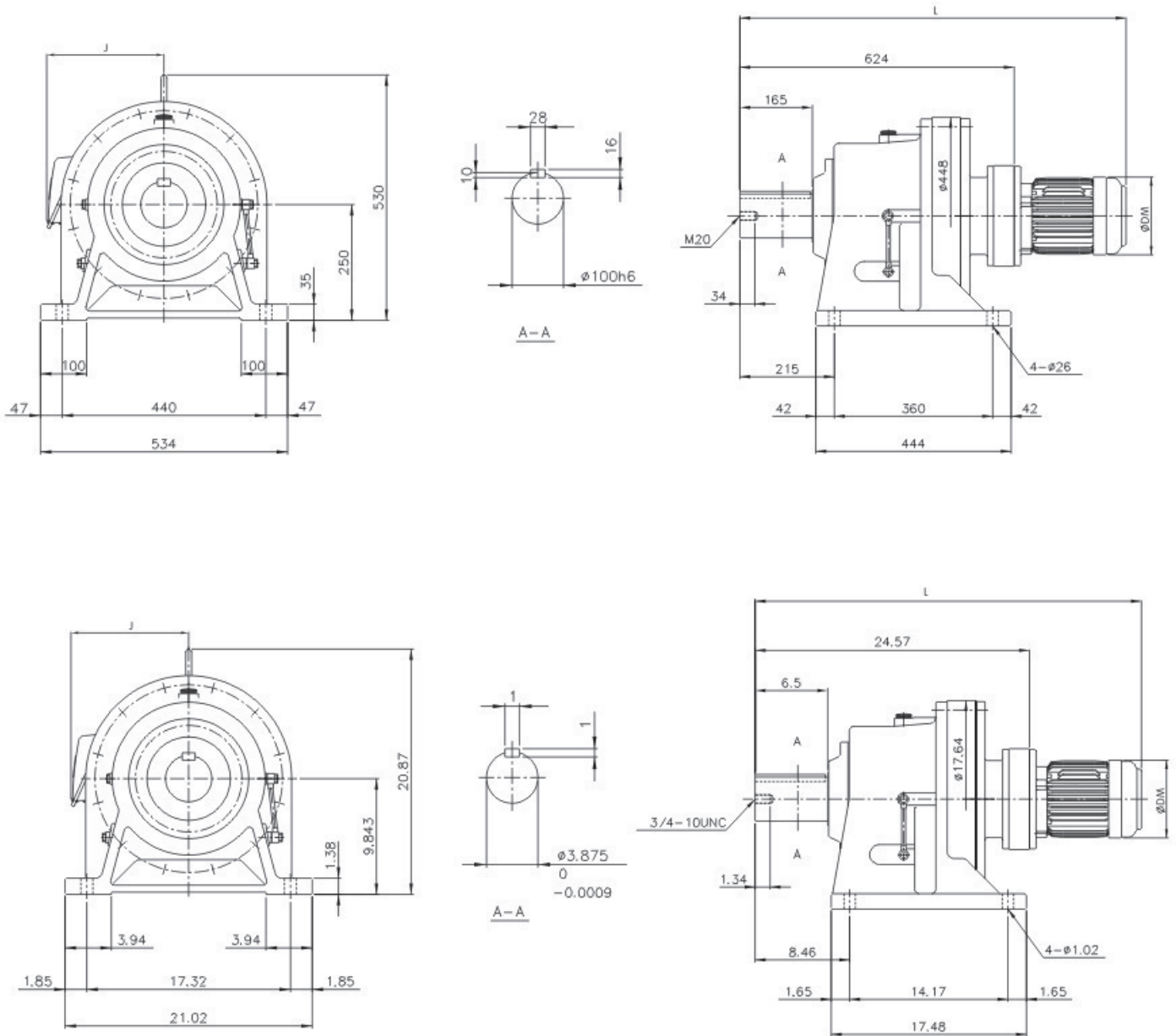

Motor			TRANSCYKO Model No.	Metric ( mm, kg )					Inches ( in.lbs )				
KW	HP	POLE		L	J	DM	H	Weight	L	J	DM	H	Weight
0.75	1	4	THHM1-620/13	868	143	177		288	34.17	5.63	6.97		633.6
1.5	2	4	THHM2-620/13	908	150	200		299	35.75	5.91	7.87		657.8
2.2	3	4	THHM3-620/13	935	173	219		309	36.81	6.81	8.62		679.8
3.7	5	4	THHM5-620/13	954	187	238		318	37.56	7.36	9.37		699.6
5.5	7.5	4	THHM8-620/13	998	218	273		316	39.29	8.58	10.75		695.2
7.5	10	4	THHM10-620/13	1036	223	273		328	40.79	8.78	10.75		721.6



**THHM-621/13**

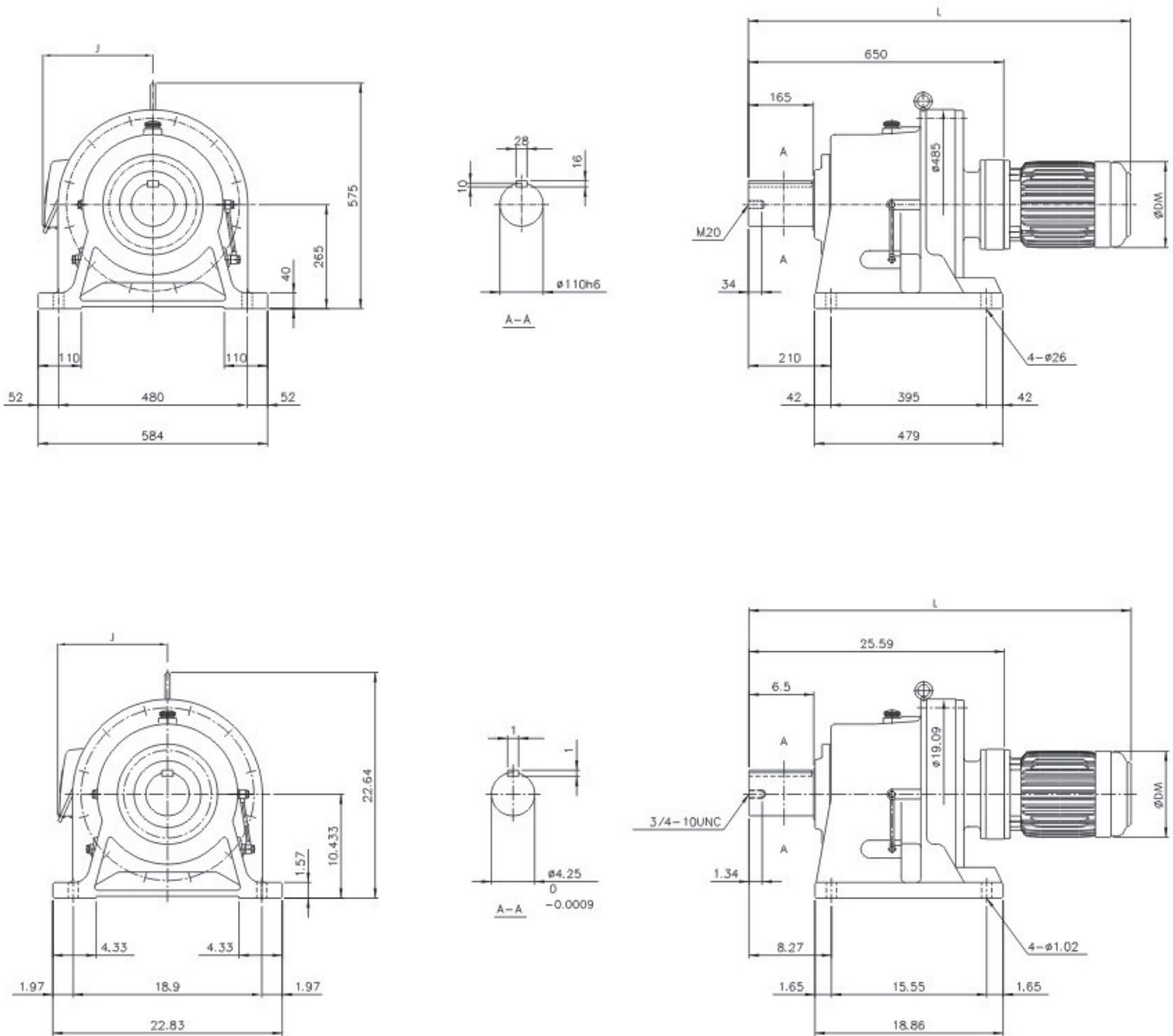

Motor			TRANSCYKO Model No.	Metric ( mm, kg )					Inches ( in.lbs )				
KW	HP	POLE		L	J	DM	H	Weight	L	J	DM	H	Weight
0.75	1	4	THHM1-621/13	894	143	177		365	35.20	5.63	6.97		803.0
1.5	2	4	THHM2-621/13	934	150	200		378	36.77	5.91	7.87		831.6
2.2	3	4	THHM3-621/13	961	173	219		390	37.83	6.81	8.62		858.0
3.7	5	4	THHM5-621/13	980	187	238		397	38.58	7.36	9.37		873.4
5.5	7.5	4	THHM8-621/13	1024	218	273		401	40.31	8.58	10.75		882.2
7.5	10	4	THHM10-621/13	1062	223	273		409	41.81	8.78	10.75		899.8

**THHM-621/16**

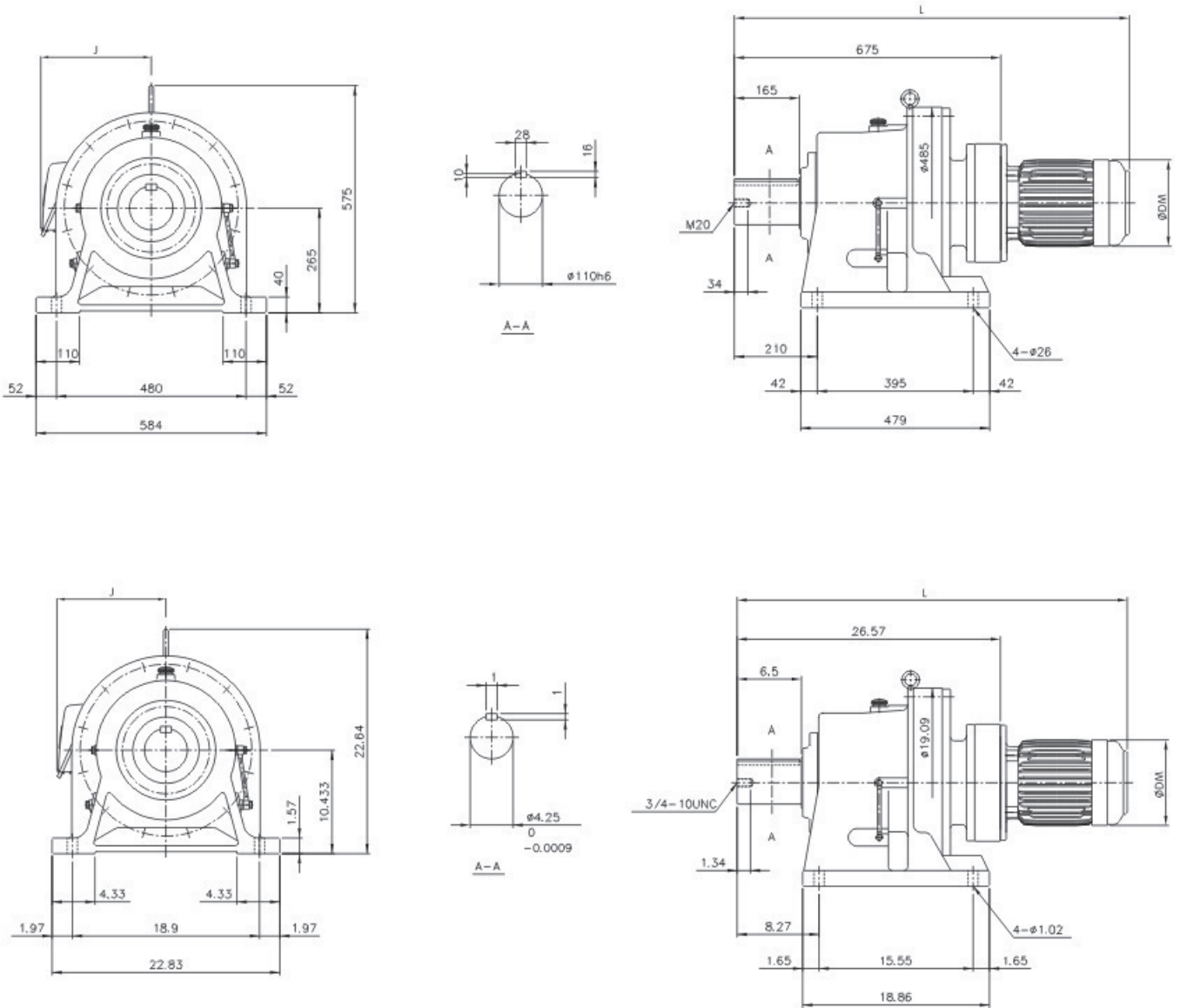

Motor			TRANSCYKO Model No.	Metric ( mm, kg )					Inches ( in.lbs )				
KW	HP	POLE		L	J	DM	H	Weight	L	J	DM	H	Weight
2.2	3	4	THHM3-621/16	989	1173	219		387	38.94	6.81	8.62		851.4
3.7	5	4	THHM5-621/16	1008	182	238		397	39.69	7.17	9.37		873.4
5.5	7.5	4	THHM8-621/16	1042	219	273		406	41.02	8.62	10.75		893.2
7.5	10	4	THHM10-621/16	1080	219	273		409	42.52	8.62	10.75		899.8
11	15	4	THHM15-621/16	1167	256	334		434	45.94	10.08	13.15		954.8



THHM-622/13

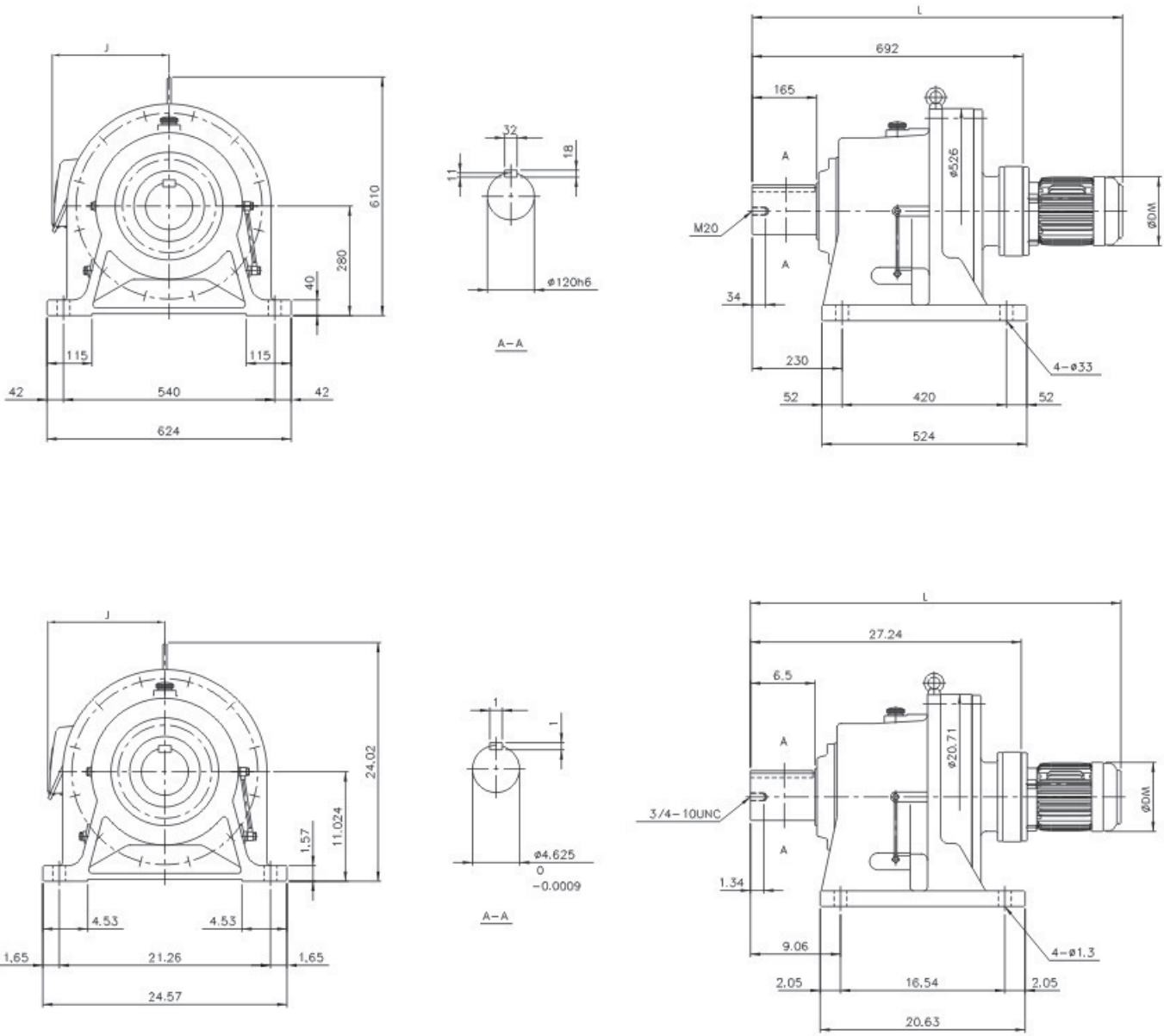

Motor			TRANSCYKO Model No.	Metric ( mm, kg )					Inches ( in.lbs )				
KW	HP	POLE		L	J	DM	H	Weight	L	J	DM	H	Weight
0.75	1	4	THHM1-622/13	936	143	177		440	36.85	5.63	6.97		968.0
1.5	2	4	THHM2-622/13	976	150	200		453	38.43	5.91	7.87		996.6
2.2	3	4	THHM3-622/13	1003	173	219		465	39.49	6.81	8.62		1023
3.7	5	4	THHM5-622/13	1022	187	238		470	40.24	7.36	9.37		1034
5.5	7.5	4	THHM8-622/13	1066	218	273		474	41.97	8.58	10.75		1043
7.5	10	4	THHM10-622/13	1104	223	273		482	43.46	8.78	10.75		1060

THHM-622/17

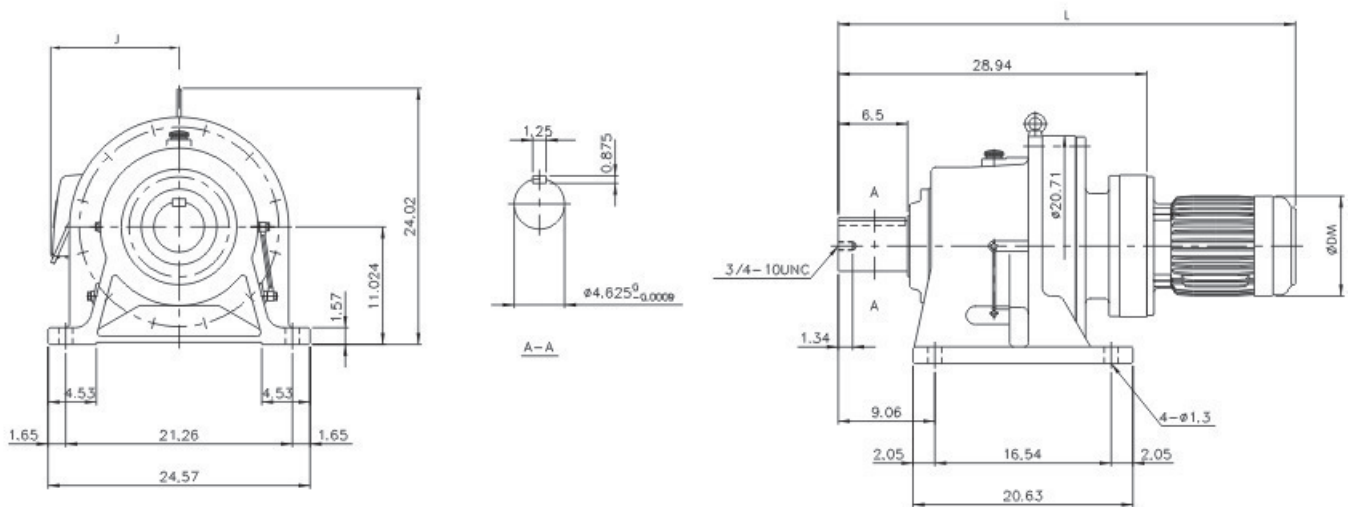
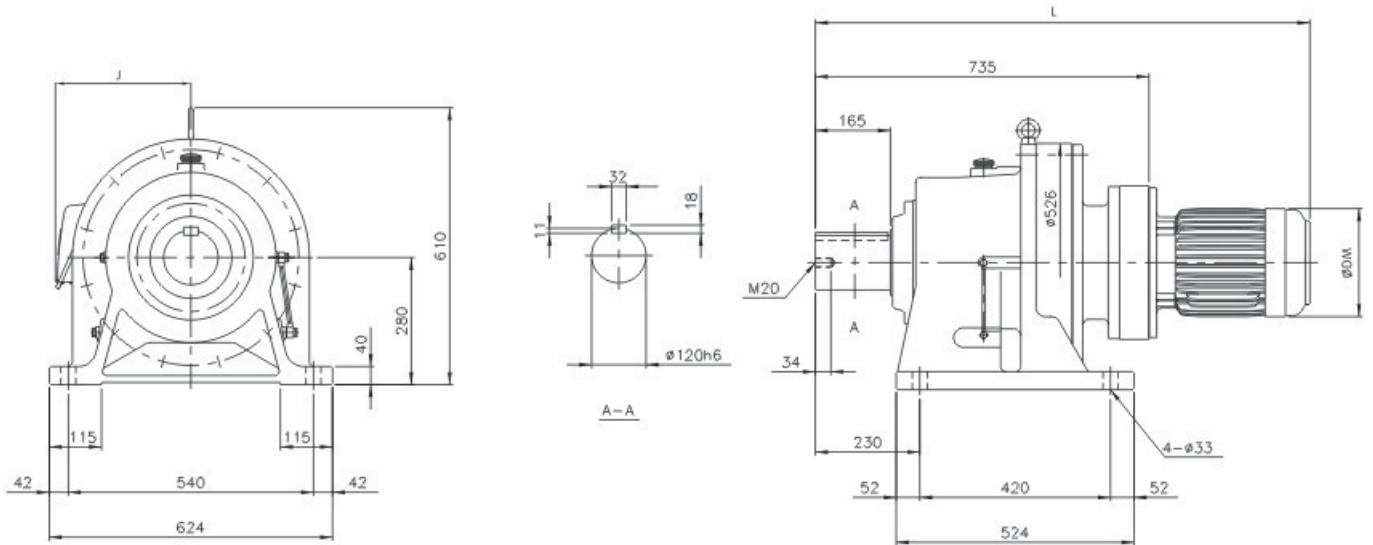

Motor			TRANSCYKO Model No.	Metric ( mm, kg )					Inches ( in.lbs )				
KW	HP	POLE		L	J	DM	H	Weight	L	J	DM	H	Weight
3.7	5	4	THHM5-622/17	1080	182	238		457	42.52	7.17	9.37		1005
5.5	7.5	4	THHM8-622/17	1114	218	273		470	43.86	8.58	10.75		1034
7.5	10	4	THHM10-622/17	1152	218	273		482	45.35	8.58	10.75		1060
11	15	4	THHM15-622/17	1227	256	334		533	48.31	10.08	13.15		1173
15	20	4	THHM20-622/17	1271	256	334		587	50.04	10.08	13.15		1291



THHM-623/16

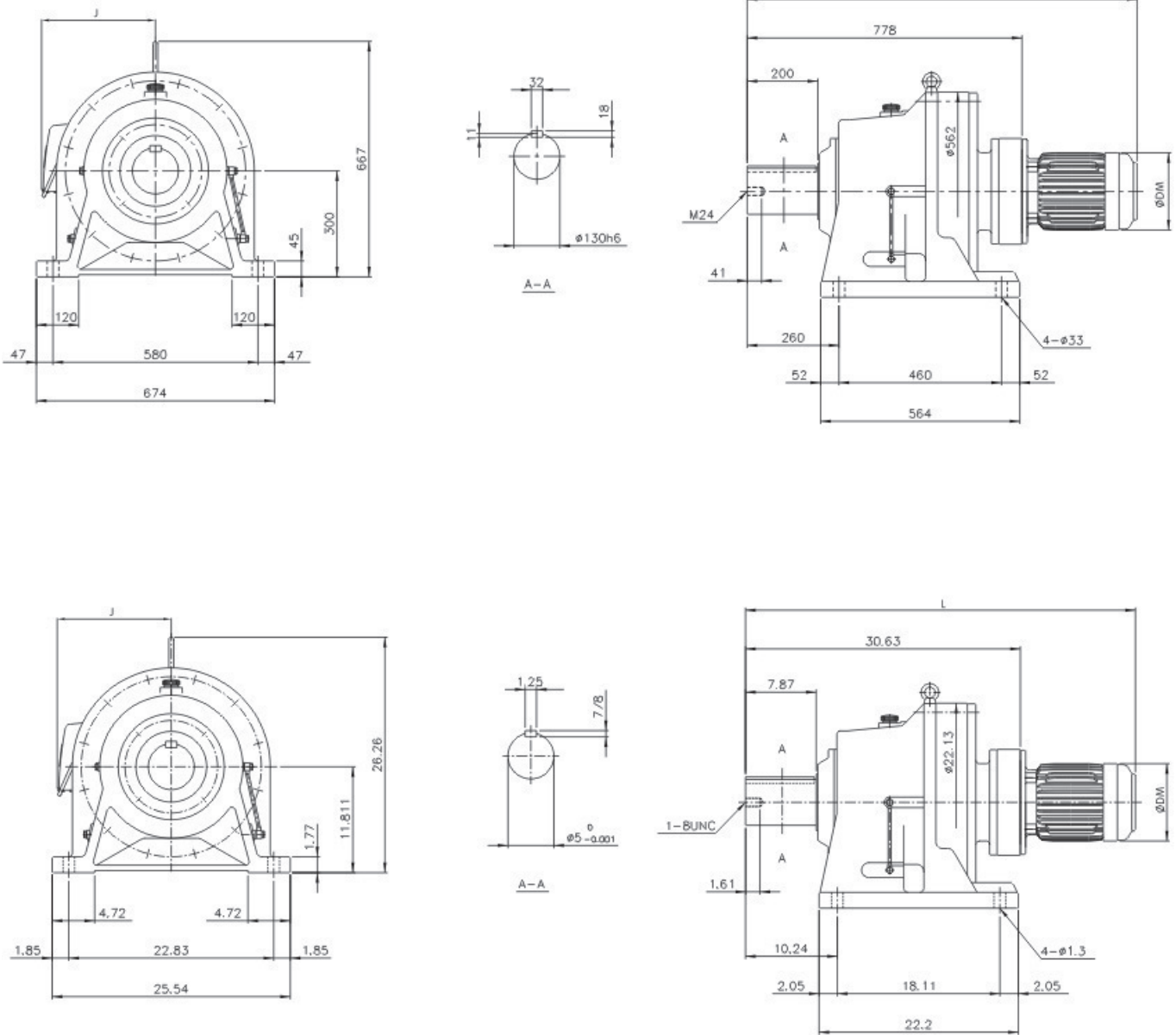

Motor			TRANSCYKO Model No.	Metric ( mm, kg )					Inches ( in.lbs )				
KW	HP	POLE		L	J	DM	H	Weight	L	J	DM	H	Weight
2.2	3	4	THHM3-623/16	1092	173	219		564	42.99	6.81	8.62		1241
3.7	5	4	THHM5-623/16	1111	182	238		586	43.74	7.17	9.37		1289
5.5	7.5	4	THHM8-623/16	1145	219	273		594	45.08	8.62	10.75		1307
7.5	10	4	THHM10-623/16	1183	219	273		607	46.57	8.62	10.75		1335
11	15	4	THHM15-623/16	1270	256	334		641	50.00	10.08	13.5		1410
15	20	4	THHM20-623/16	1314	256	334		660	51.73	10.08	13.5		1452

THHM-623/18

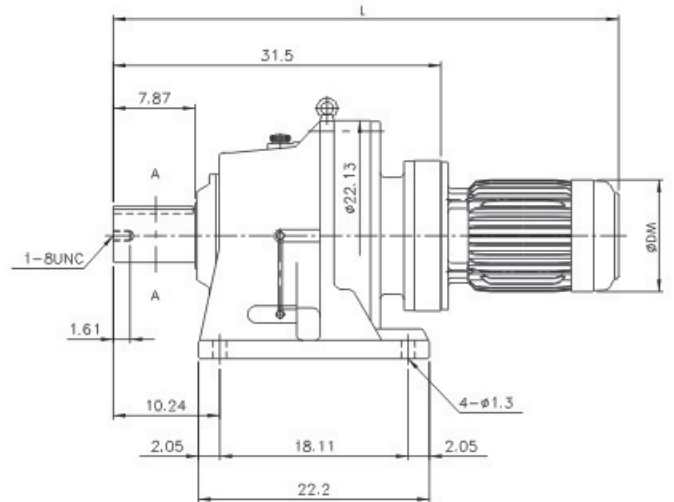
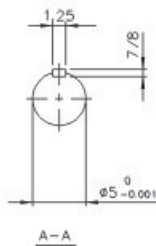
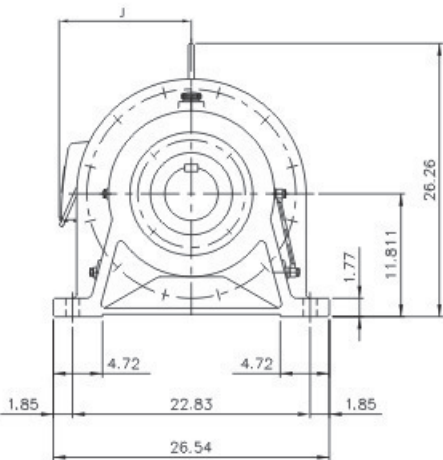
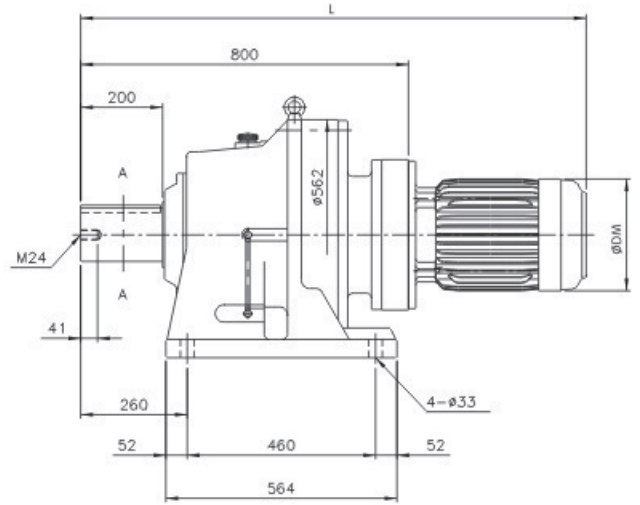
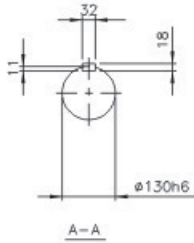
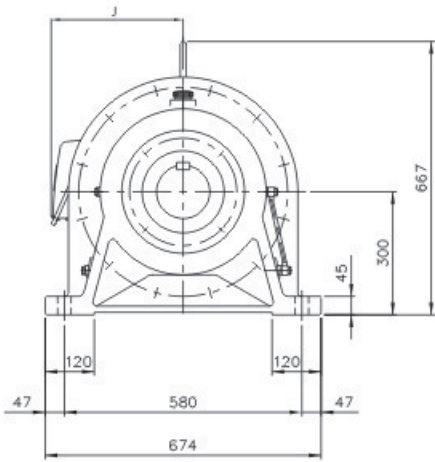

Motor			TRANSCYKO Model No.	Metric ( mm, kg )					Inches ( in.lbs )				
KW	HP	POLE		L	J	DM	H	Weight	L	J	DM	H	Weight
7.5	10	4	THHM10-623/18	1226	224	275		610	48.27	8.82	10.75		1342
11	15	4	THHM15-623/18	1294	256	334		694	50.94	10.08	13.15		1527
15	20	4	THHM20-623/18	1338	256	334		699	52.68	10.08	13.15		1538
18.5	25	4	THHM25-623/18	1361	305	382		761	53.58	12.01	15.04		1674
22	30	4	THHM30-623/18	1361	305	382		761	53.58	12.01	15.04		1674



THHM-624/16

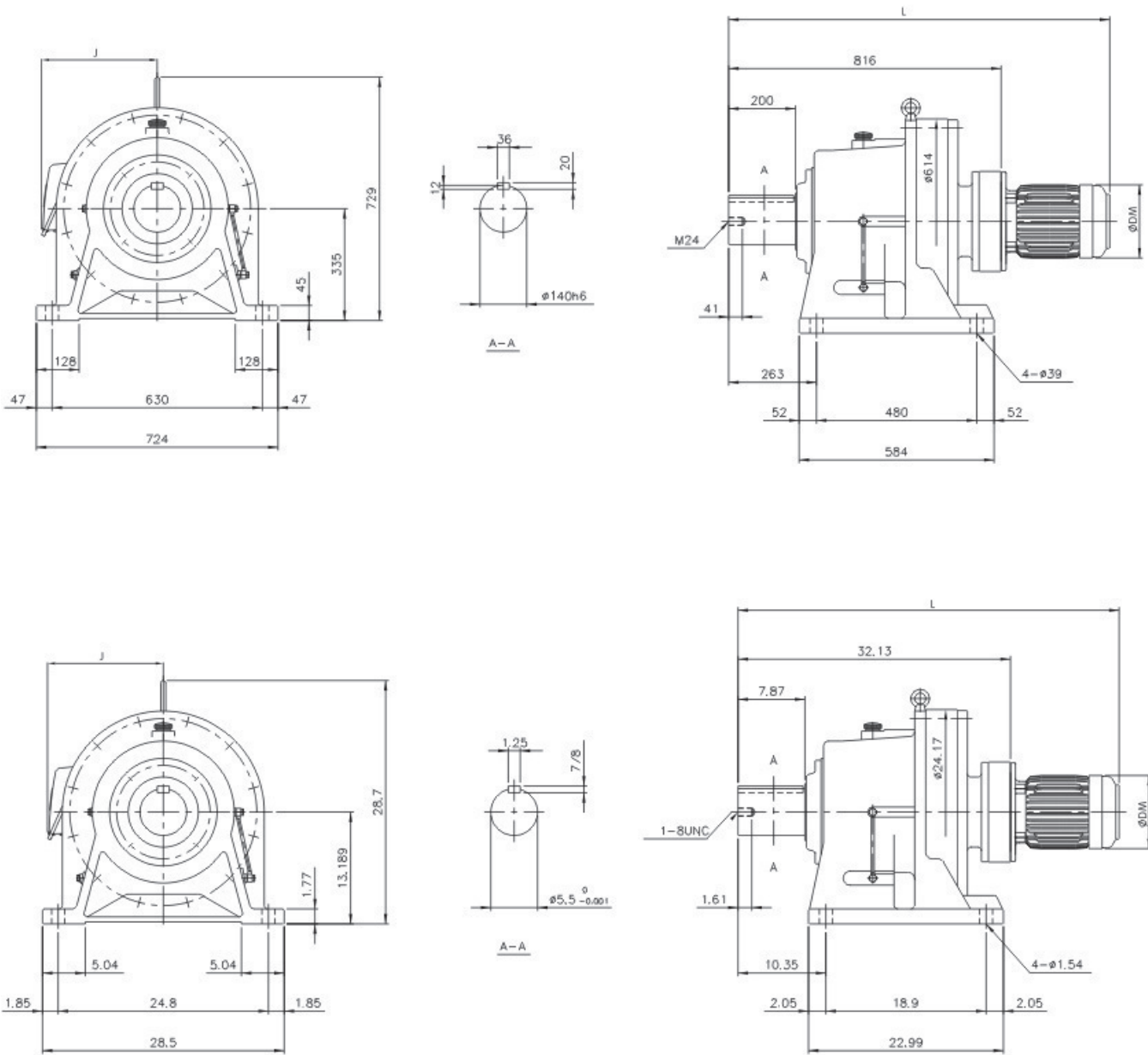

Motor			TRANSCYKO Model No.	Metric ( mm, kg )					Inches ( in.lbs )				
KW	HP	POLE		L	J	DM	H	Weight	L	J	DM	H	Weight
2.2	3	4	THHM3-624/16	1130	173	219		675	44.49	6.81	8.62		1485
3.7	5	4	THHM5-624/16	1149	182	238		687	45.24	7.17	9.37		1514
5.5	7.5	4	THHM8-624/16	1183	219	273		703	46.57	8.62	10.75		1546
7.5	10	4	THHM10-624/16	1221	219	273		718	48.07	8.62	10.75		1580
11	15	4	THHM15-624/16	1308	256	334		750	51.50	10.08	13.5		1650
15	20	4	THHM20-624/16	1352	256	334		769	53.22	10.08	13.5		1692

THHM-624/18

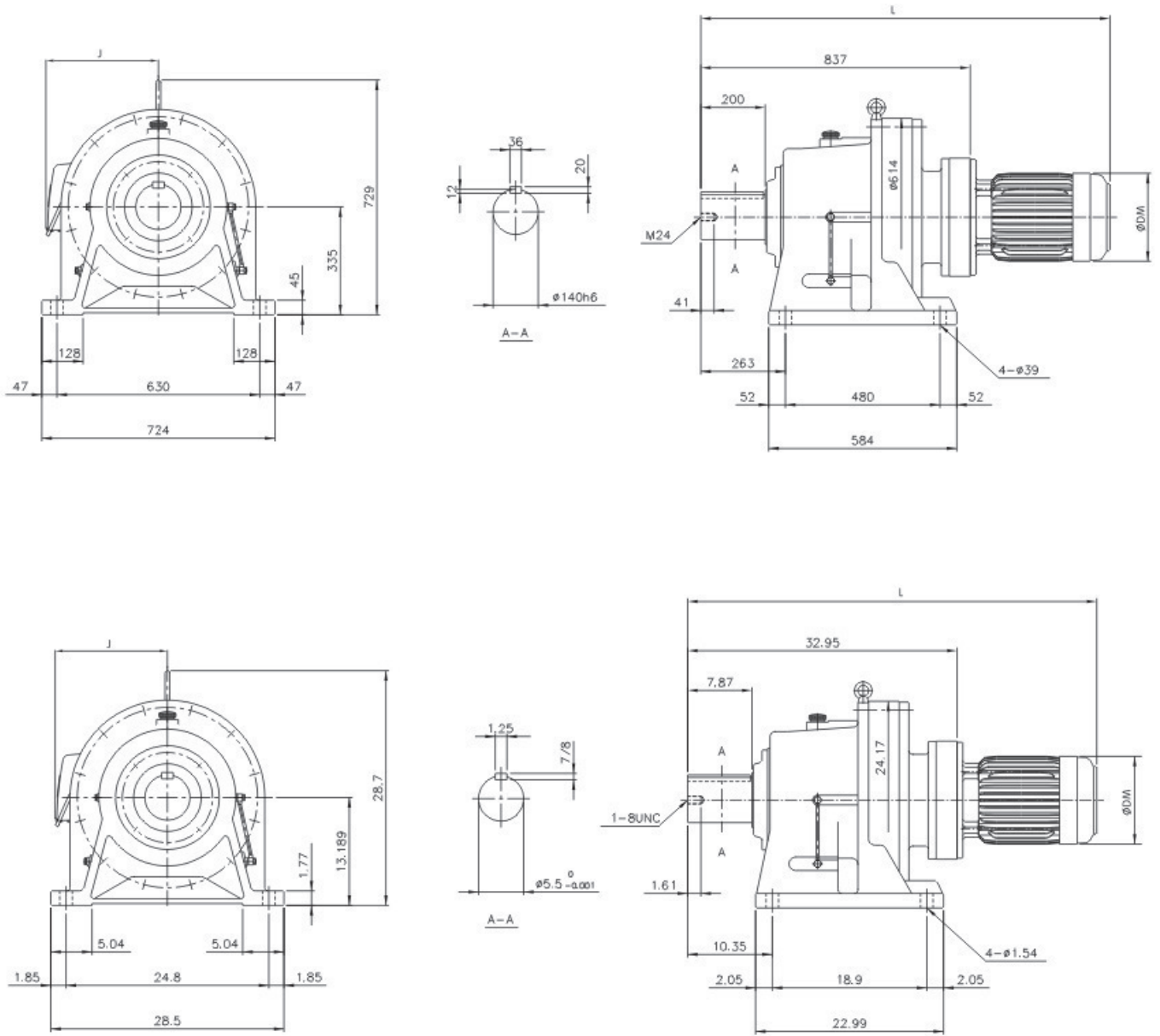

Motor			TRANSCYKO Model No.	Metric ( mm, kg )					Inches ( in.lbs )				
KW	HP	POLE		L	J	DM	H	Weight	L	J	DM	H	Weight
7.5	10	4	THHM10-624/18	1263	224	273		705	49.72	8.82	10.75		1551
11	15	4	THHM15-624/18	1331	256	334		738	52.40	10.08	13.15		1624
15	20	4	THHM20-624/18	1375	256	334		798	54.13	10.08	13.15		1756
18.5	25	4	THHM25-624/18	1398	305	382		862	55.04	12.01	15.04		1896
22	30	4	THHM30-624/18	1398	305	382		862	55.04	12.01	15.04		1896



# THHM-625/17

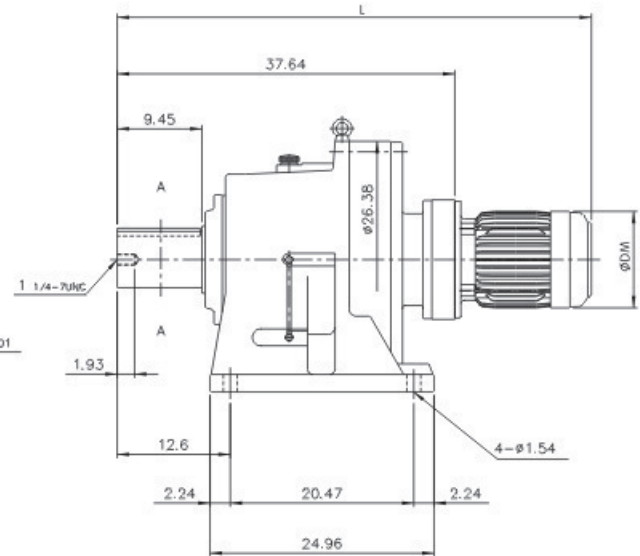
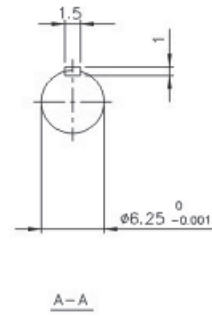
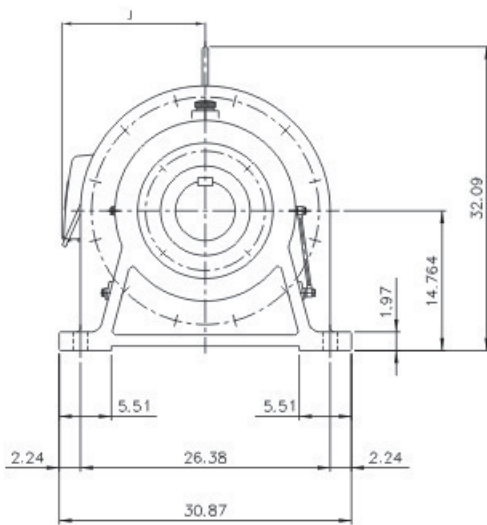
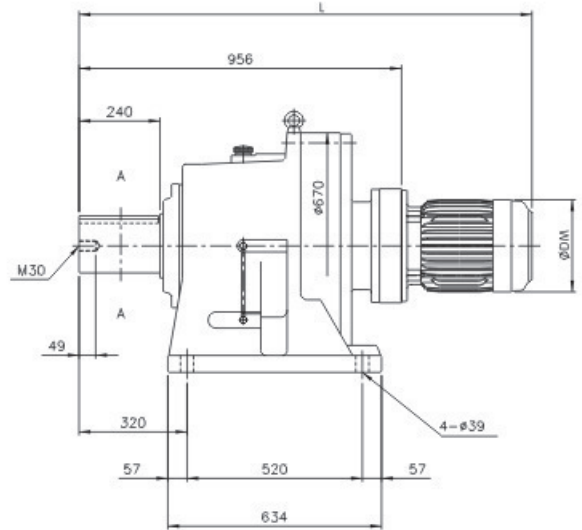
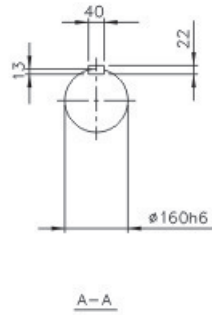
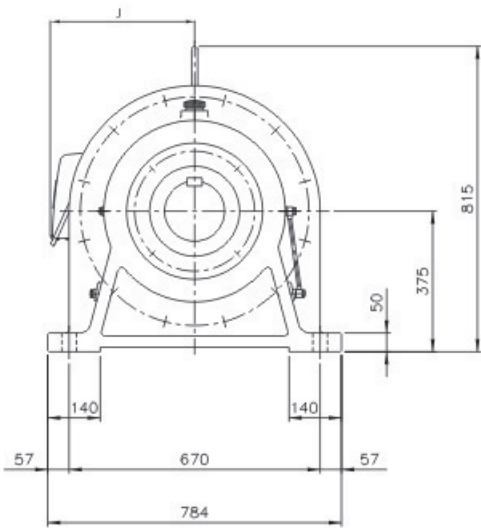

Motor			TRANSCYKO Model No.	Metric ( mm, kg )					Inches ( in.lbs )				
KW	HP	POLE		L	J	DM	H	Weight	L	J	DM	H	Weight
3.7	5	4	THHM5-625/17	1301	182	238		1055	51.22	7.17	9.37		2321
5.5	7.5	4	THHM8-625/17	1335	218	273		1071	52.56	8.58	10.75		2356
7.5	10	4	THHM10-625/17	1373	218	273		1083	54.06	8.58	10.75		2338
11	15	4	THHM15-625/17	1448	256	334		1104	57.01	10.08	13.15		2429
15	20	4	THHM20-625/17	1492	256	334		1121	58.74	10.08	13.15		2466
18.5	25	4	THHM25-625/17	1517	305	382		1190	59.72	12.01	15.04		2618
22	30	4	THHM30-625/17	1517	305	382		1190	59.72	12.01	15.04		2618

THHM-625/19

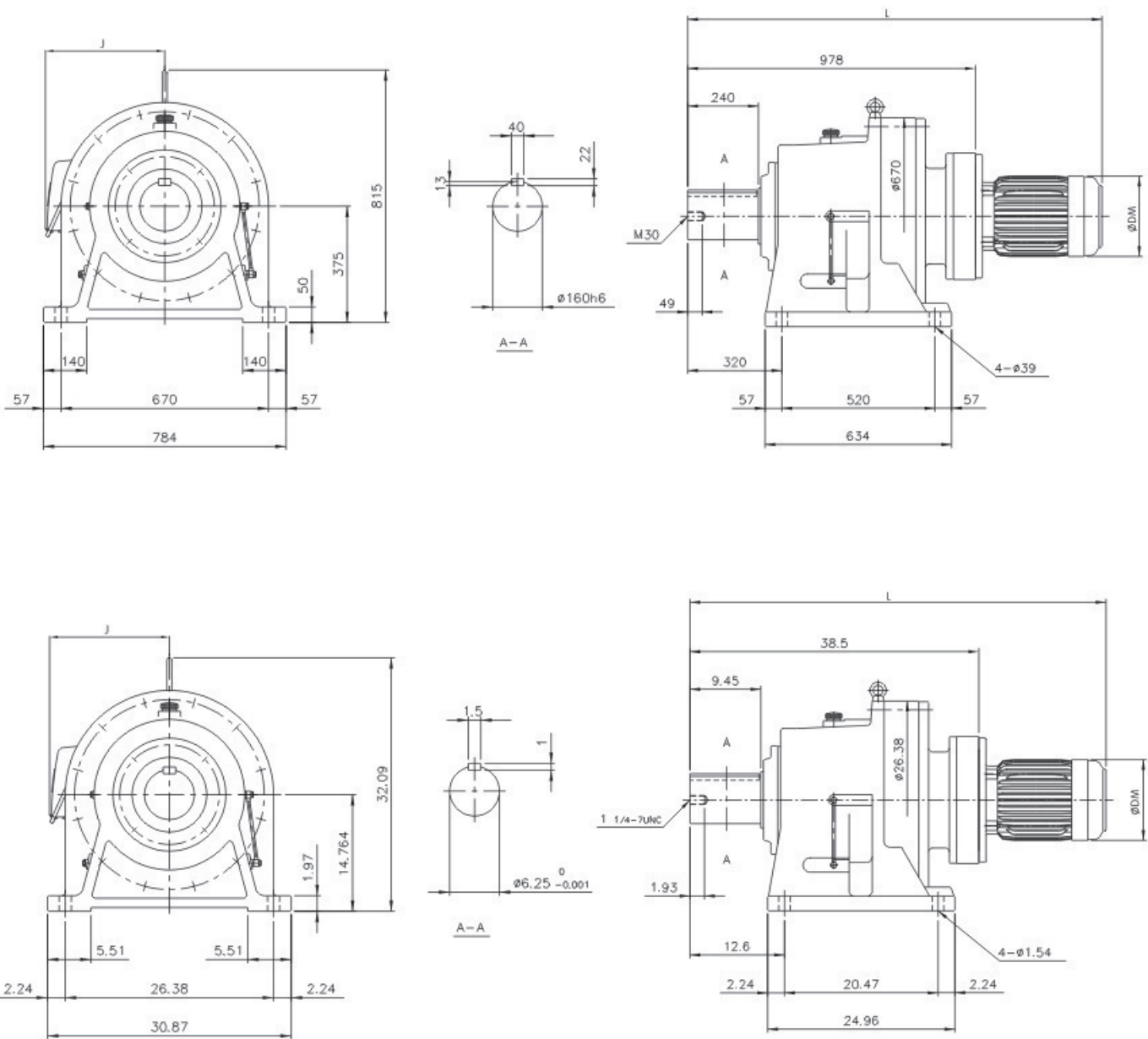

Motor			TRANSCYKO Model No.	Metric ( mm, kg )					Inches ( in.lbs )				
KW	HP	POLE		L	J	DM	H	Weight	L	J	DM	H	Weight
7.5	10	4	THHM10-625/19	1401	224	273		1081	55.16	8.82	10.75		2378
11	15	4	THHM15-625/19	1476	261	334		1140	58.11	10.28	13.15		2508
15	20	4	THHM20-625/19	1520	261	334		1190	59.84	10.28	13.15		2620
18.5	25	4	THHM25-625/19	1539	305	382		1264	60.59	12.01	15.04		2781
22	30	4	THHM30-625/19	1539	305	382		1264	60.59	12.01	15.04		2781
30	40	4	THHM40-625/19	1577	305	382		1280	62.09	12.01	15.04		2816



THHM-626/19

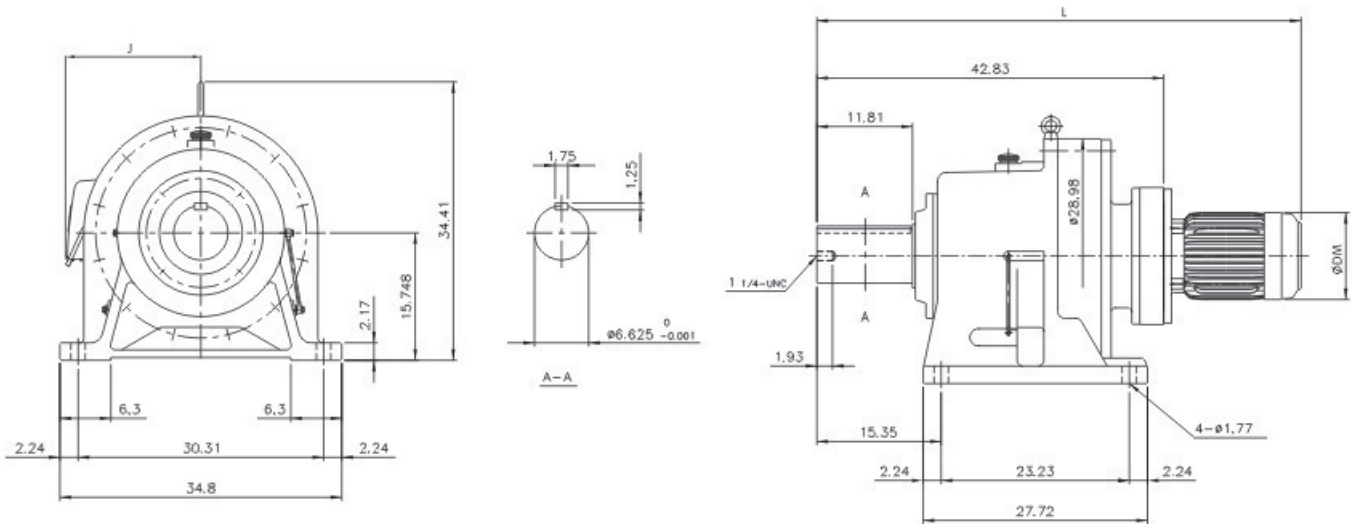
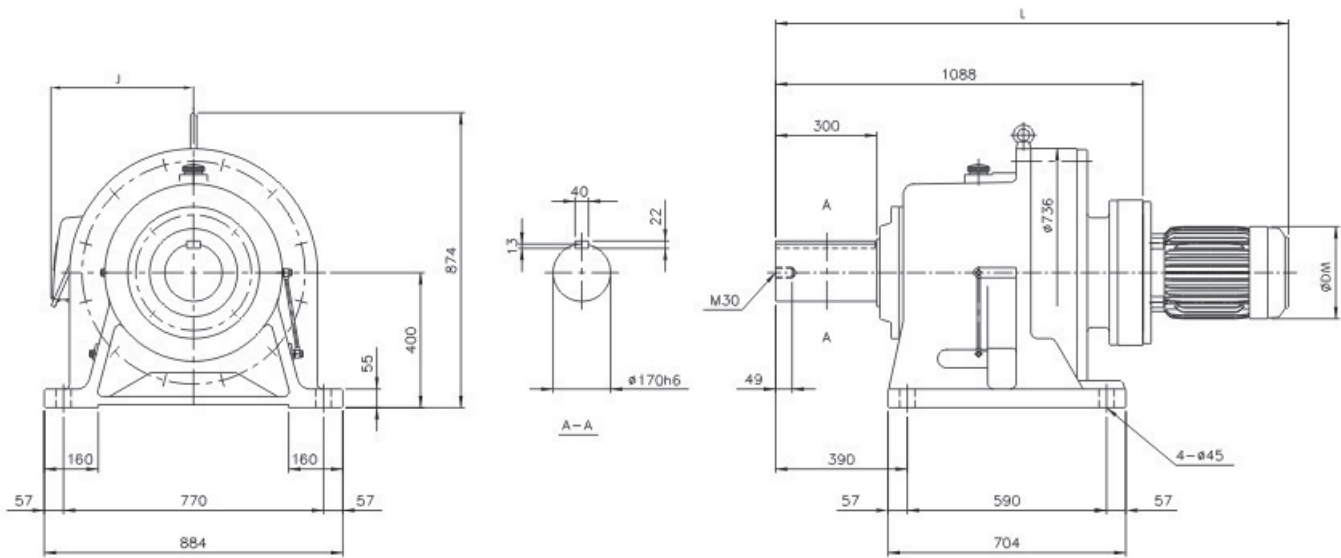

Motor			TRANSCYKO Model No.	Metric ( mm, kg )					Inches ( in.lbs )				
KW	HP	POLE		L	J	DM	H	Weight	L	J	DM	H	Weight
5.5	7.5	4	THHM8-626/19	1473	224	273		1251	57.99	8.82	10.75		2752
7.5	10	4	THHM10-626/19	1511	224	273		1263	59.49	8.82	10.75		2779
11	15	4	THHM15-626/19	1586	261	334		1394	62.44	10.28	13.15		3067
15	20	4	THHM20-626/19	1630	261	334		1444	64.17	10.28	13.15		3177
18.5	25	4	THHM25-626/19	1649	305	382		1519	64.92	12.01	15.04		3342
22	30	4	THHM30-626/19	1649	305	382		1519	64.92	12.01	15.04		3342
30	40	4	THHM40-626/19	1687	305	382		1535	66.42	12.01	15.04		3377
37	50	4	THHM50-626/19	1750	339	420		1569	69.90	13.35	16.54		3452

**THHM-627/19**

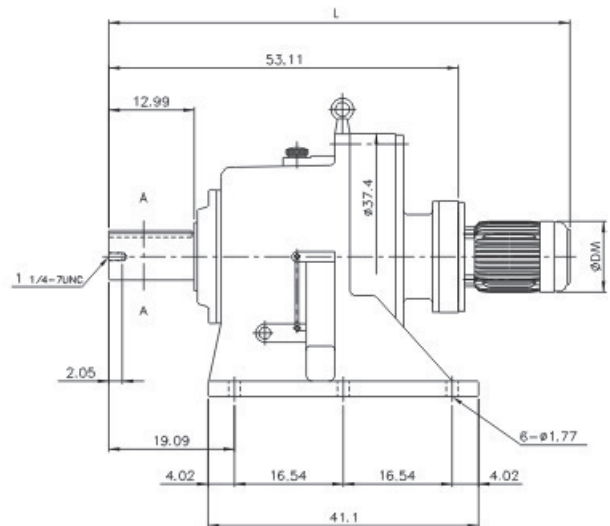
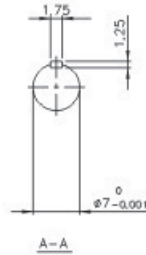
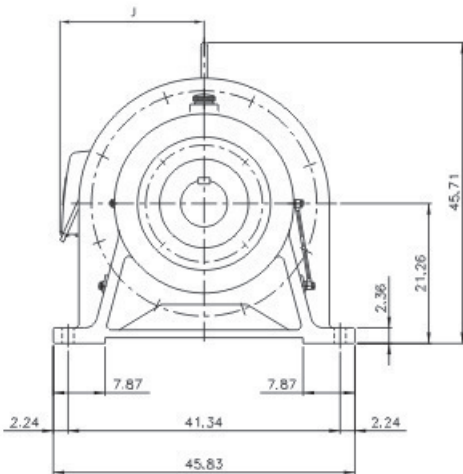
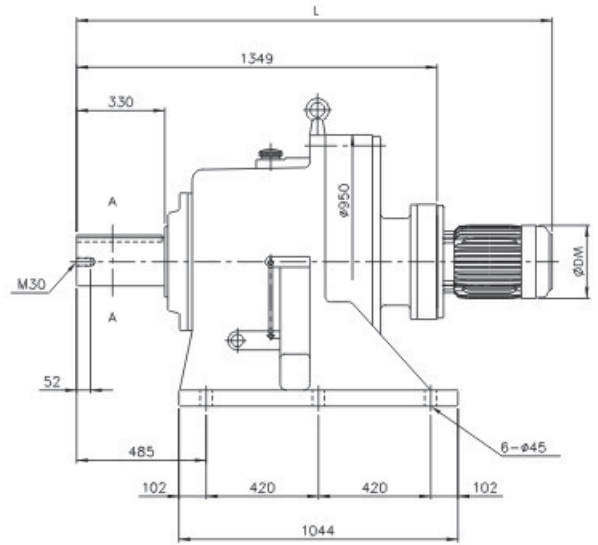
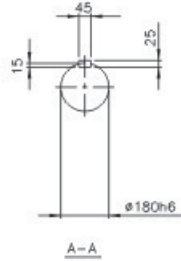
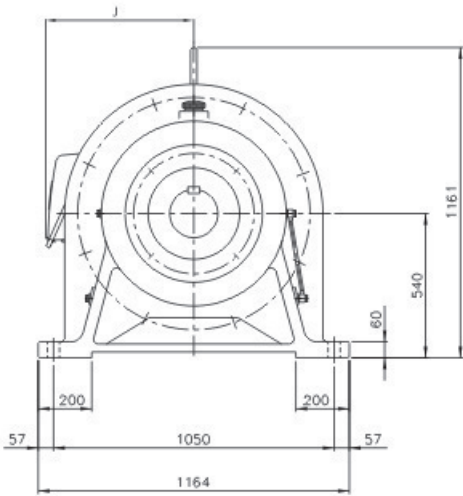

Motor			TRANSCYKO Model No.	Metric ( mm, kg )					Inches ( in.lbs )				
KW	HP	POLE		L	J	DM	H	Weight	L	J	DM	H	Weight
5.5	7.5	4	THHM8-627/19	1734	224	273		2501	68.27	8.82	10.75		5502
7.5	10	4	THHM10-627/19	1772	224	273		2533	69.76	8.82	10.75		5573
11	15	4	THHM15-627/19	1847	261	334		2529	72.72	10.28	13.15		5564
15	20	4	THHM20-627/19	1891	261	334		2579	74.45	10.28	13.15		5674
18.5	25	4	THHM25-627/19	1910	305	382		2654	75.20	12.01	15.04		5839
22	30	4	THHM30-627/19	1910	305	382		2654	75.20	12.01	15.04		5839
30	40	4	THHM40-627/19	1948	305	382		2670	76.69	12.01	15.04		5874
37	50	4	THHM50-627/19	2011	339	420		2703	76.69	13.35	16.54		5947



# DIMENSION DRAWINGS For Single Stage Reduction, Vertical TRANSCYKO Gearmotor

**TVM-607**

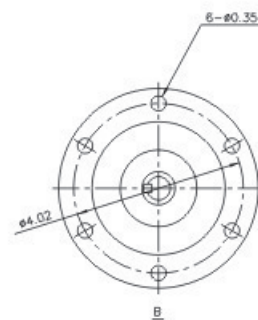
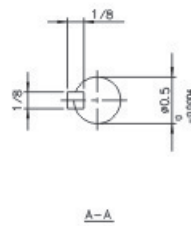
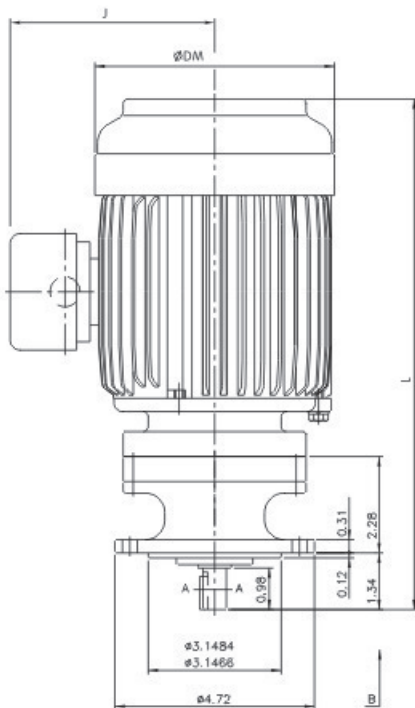
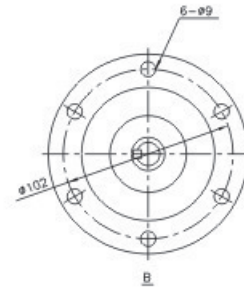
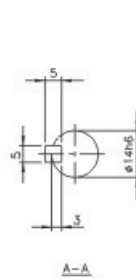
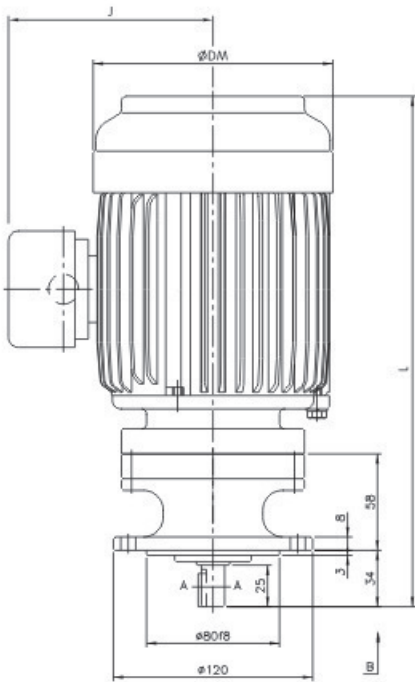

Motor			TRANSCYKO Model No.	Metric ( mm, kg )					Inches ( in.lbs )				
KW	HP	POLE		L	J	DM	H	Weight	L	J	DM	H	Weight
0.2	1/4	4	TVM02-607	311	121	144		13	12.24	4.76	5.67		26.4

TVM-608

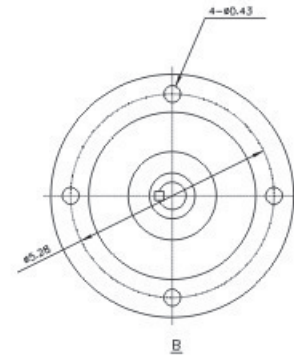
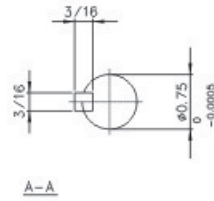
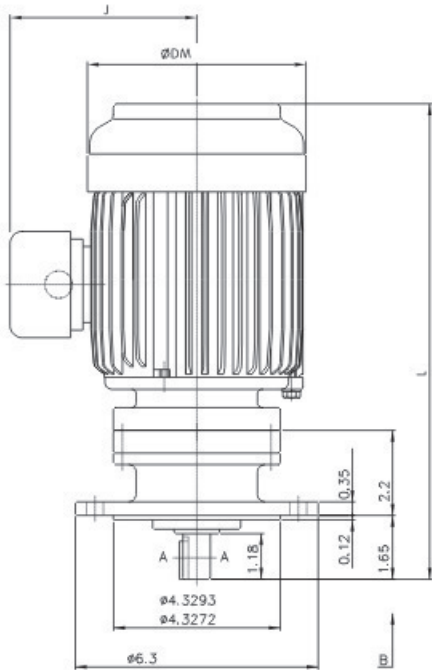
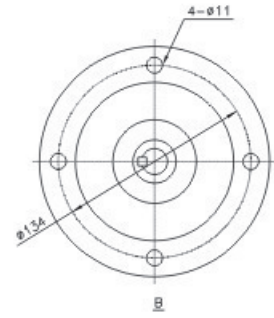
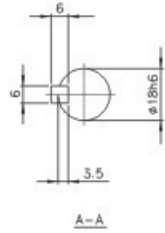
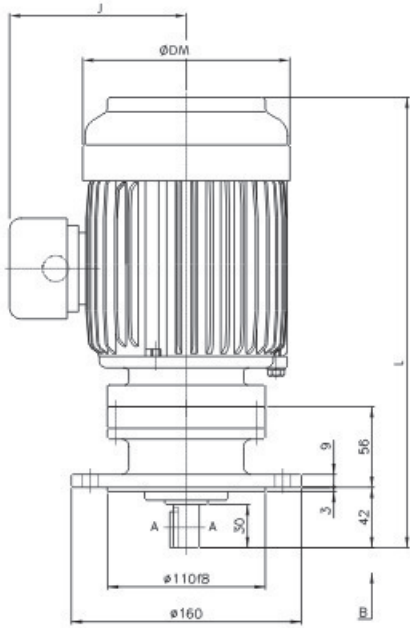

Motor			TRANSCYKO Model No.	Metric ( mm, kg )					Inches ( in.lbs )				
KW	HP	POLE		L	J	DM	H	Weight	L	J	DM	H	Weight
0.2	1/4	4	TVM02-608	311	121	144		14	12.48	4.76	5.67		30.8
0.4	1/2	4	TVM05-608	325	132	162		16	13.31	5.20	6.38		35.2





# TVM-610

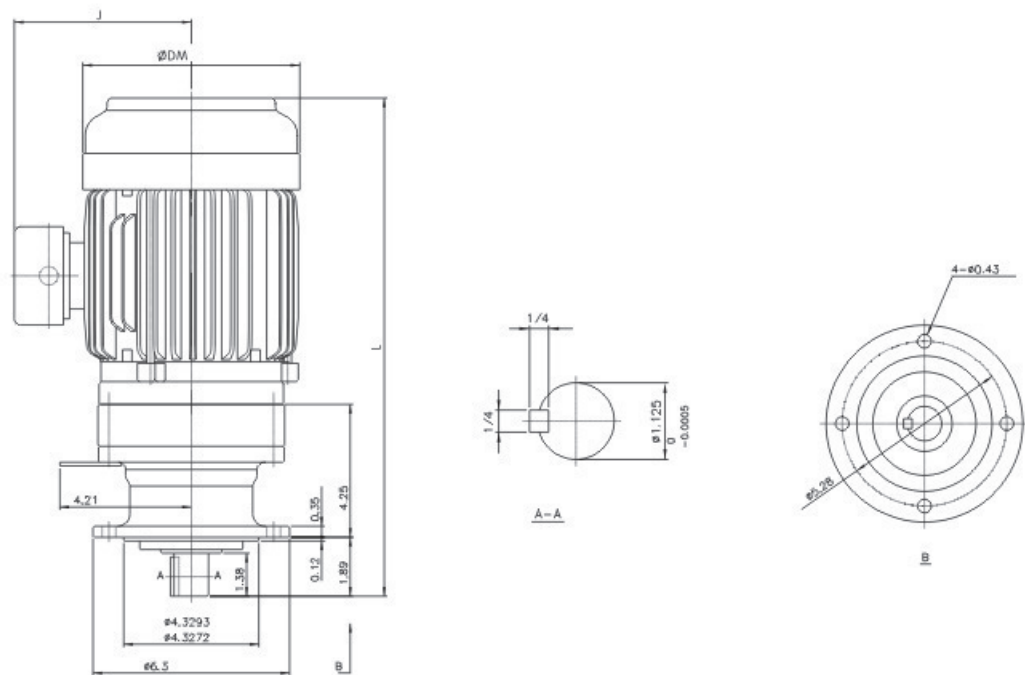
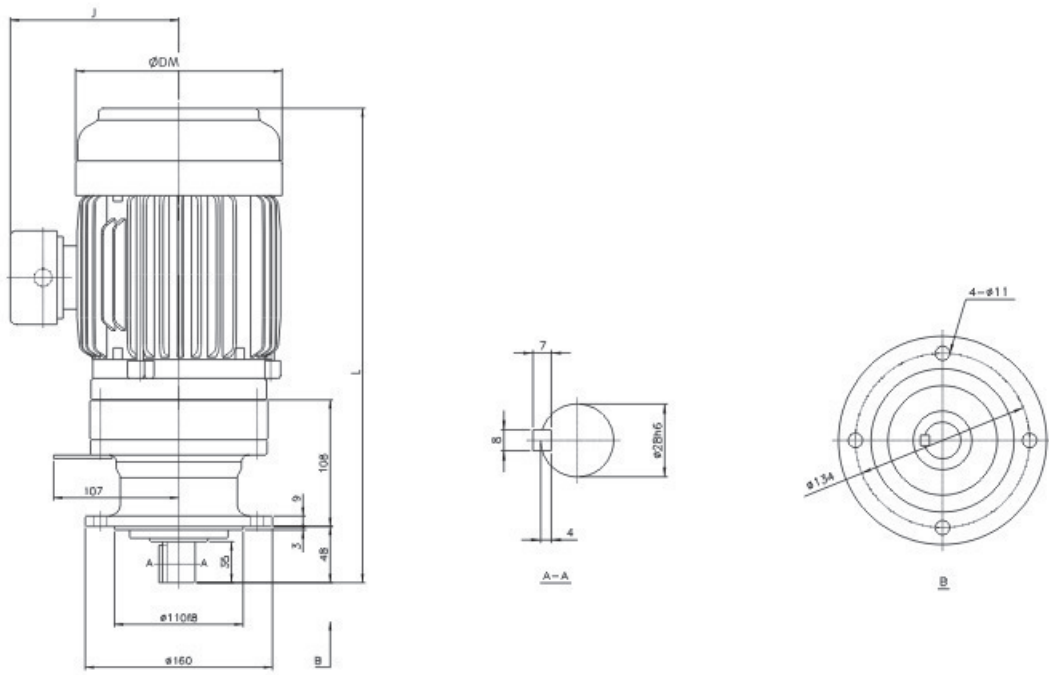

Motor			TRANSCYKO Model No.	Metric ( mm, kg )					Inches ( in.lbs )				
KW	HP	POLE		L	J	DM	H	Weight	L	J	DM	H	Weight
0.2	1/4	4	TVM02-610	375	121	144		20	14.76	4.76	5.67		44.0
0.4	1/2	4	TVM05-610	396	132	162		22	15.59	5.20	6.38		48.4
0.75	1	4	TVM1-610	395	137	177		26	15.55	5.39	6.97		57.2
1.5	2	4	TVM2-610	432	150	200		35	17.01	5.91	7.87		77.0
2.2	3	4	TVM3-610	467	173	219		45	18.39	6.81	8.62		99.0



TVM-611

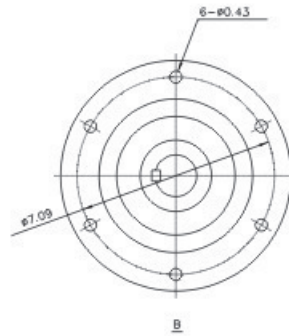
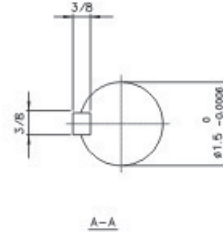
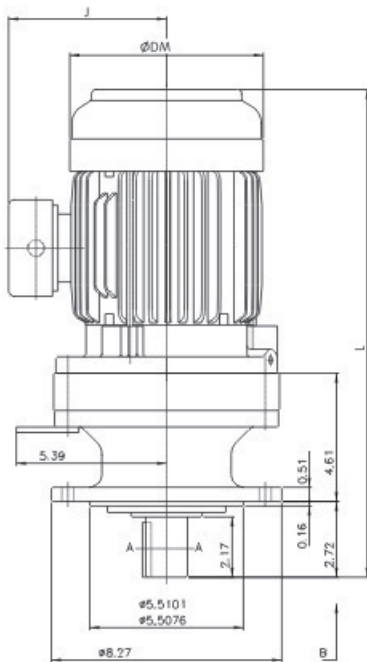
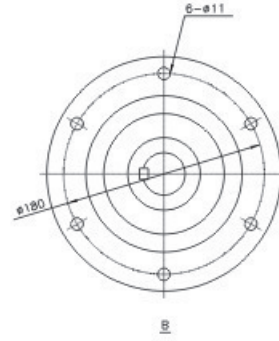
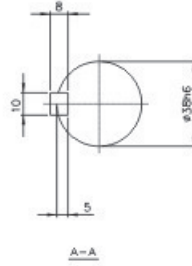
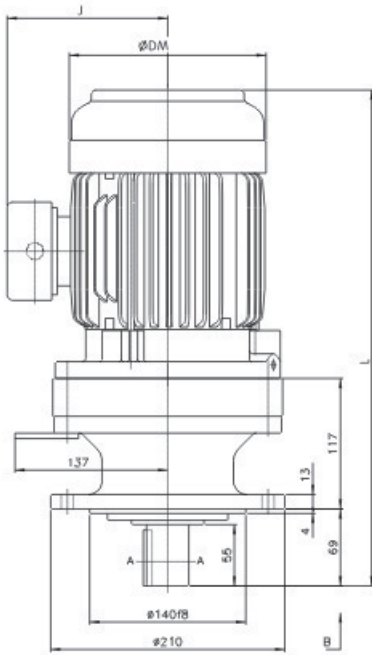

Motor			TRANSCYKO Model No.	Metric ( mm, kg )					Inches ( in.lbs )				
KW	HP	POLE		L	J	DM	H	Weight	L	J	DM	H	Weight
0.4	1/2	4	TVM05-611	425	132	162		35	16.73	5.20	6.38		77.0
0.75	1	4	TVM1-611	434	137	177		38	17.09	5.39	6.97		83.6
1.5	2	4	TVM2-611	471	156	200		47	18.54	5.91	7.87		103.8
2.2	3	4	TVM3-611	497	173	219		56	19.57	6.81	8.62		123.2
3.7	5	4	TVM5-611	513	188	238		67	20.20	7.40	9.37		147.4

TVM-612

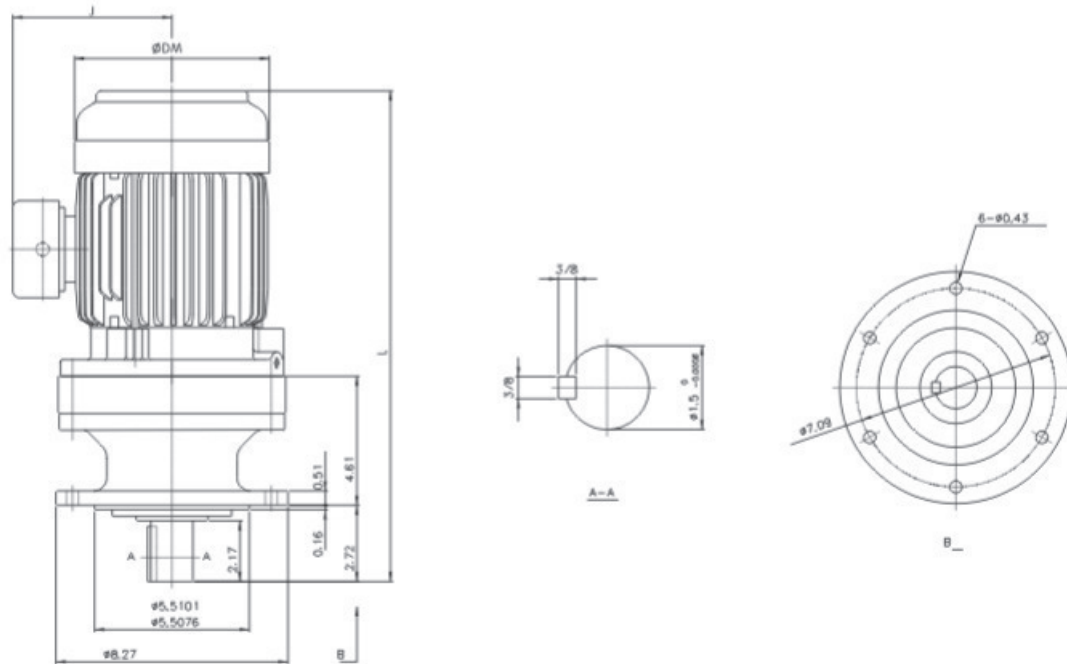
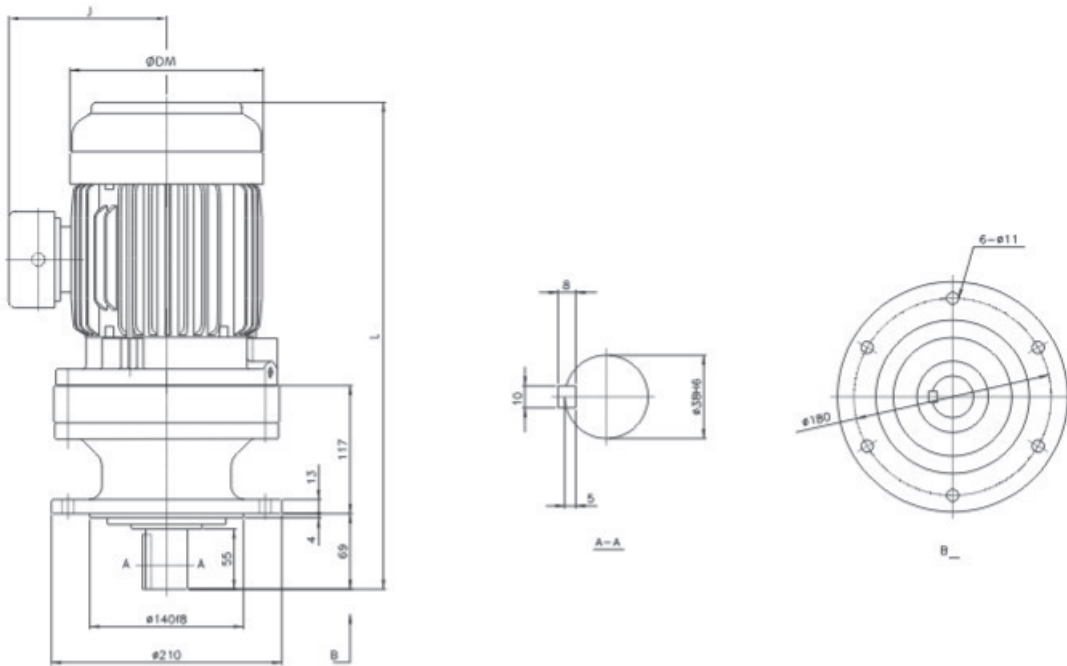

Motor			TRANSCYKO Model No.	Metric ( mm, kg )					Inches ( in.lbs )				
KW	HP	POLE		L	J	DM	H	Weight	L	J	DM	H	Weight
0.75	1	4	TVM1-612	434	137	177		38	17.09	5.39	6.97		83.6
2.2	3	4	TVM3-612	497	173	219		56	19.57	6.81	8.62		123.2
3.7	5	4	TVM5-612	513	188	238		67	20.20	7.40	9.37		147.4
5.5	7.5	4	TVM8-612	557	223	273		86	21.93	8.78	10.75		189.2

**TDVM-613**

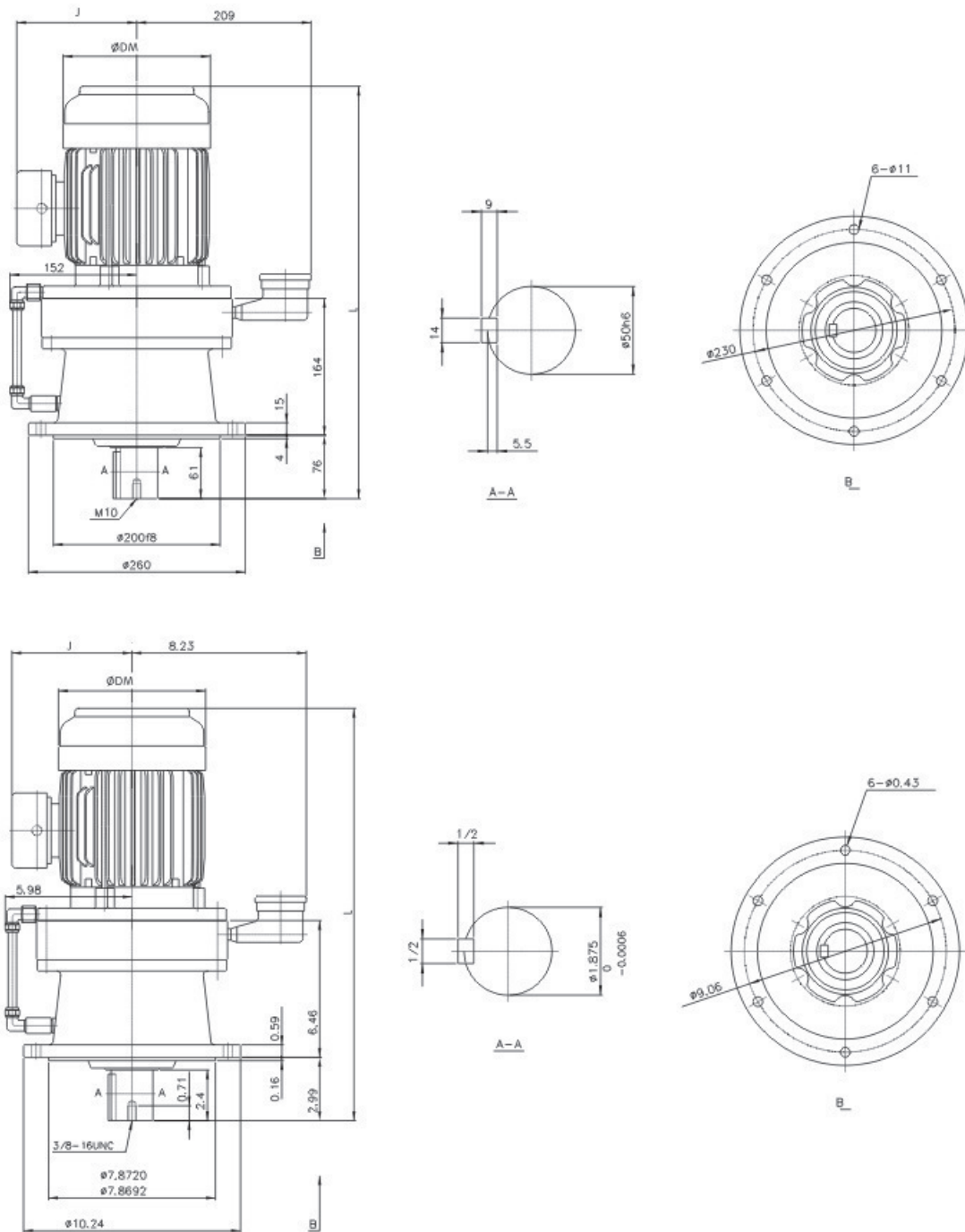

Motor			TRANSCYKO Model No.	Metric ( mm, kg )					Inches ( in.lbs )				
KW	HP	POLE		L	J	DM	H	Weight	L	J	DM	H	Weight
0.75	1	4	TDVM1-613	484	143	177		57	19.06	5.63	6.97		125.4
1.5	2	4	TDVM2-613	524	150	200		66	20.63	5.91	7.87		145.2
2.2	3	4	TDVM3-613	551	173	219		78	21.69	6.81	8.62		171.6
3.7	5	4	TDVM5-613	570	187	238		89	22.44	7.36	9.37		195.8
5.5	7.5	4	TDVM8-613	614	218	273		103	24.17	8.58	10.75		226.6
7.5	10	4	TDVM10-613	652	223	273		115	25.67	8.78	10.75		253.0



**TDVM-614**

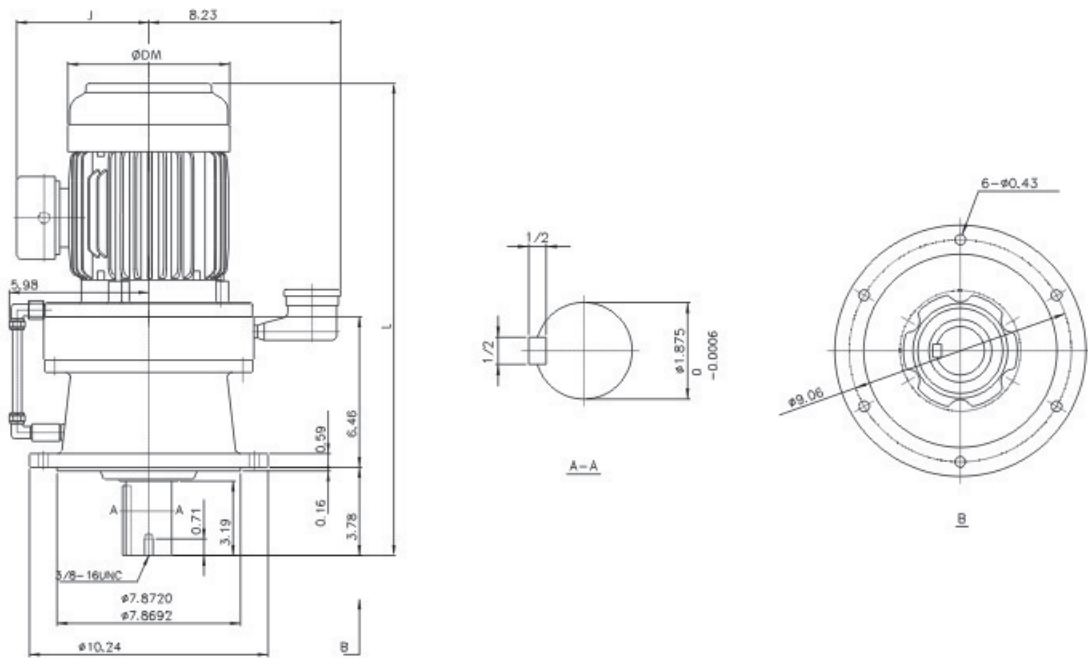
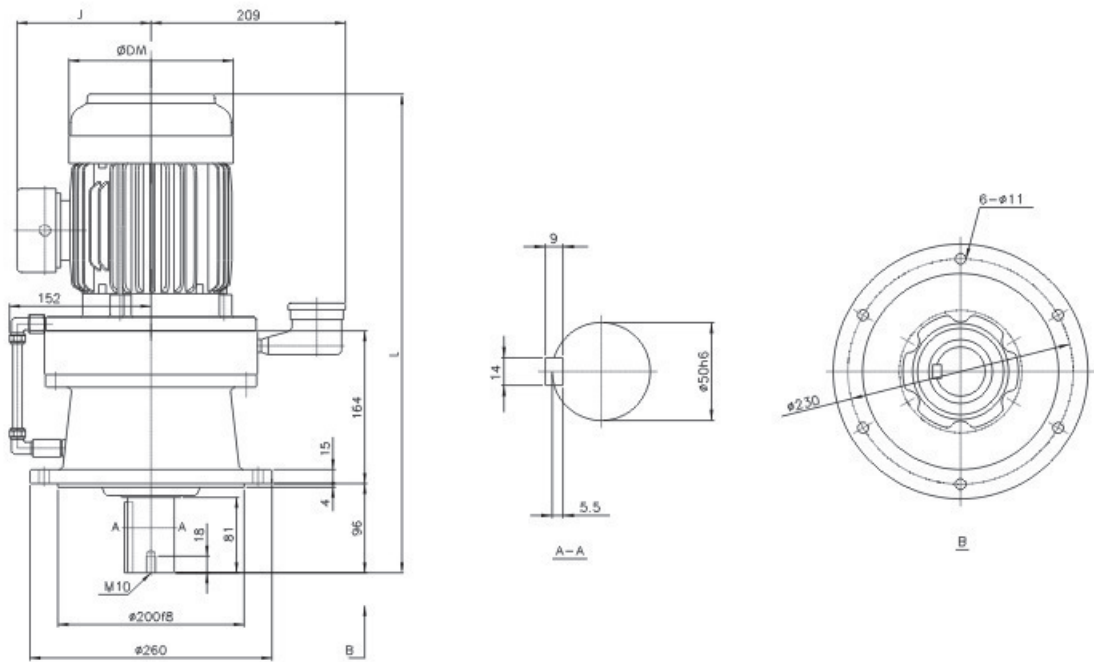

Motor			TRANSCYKO Model No.	Metric ( mm, kg )					Inches ( in.lbs )				
KW	HP	POLE		L	J	DM	H	Weight	L	J	DM	H	Weight
0.75	1	4	TDVM1-614	504	143	177		58	19.84	5.63	6.97		127.6
1.5	2	4	TDVM2-614	544	150	200		67	21.42	5.91	7.87		147.4
2.2	3	4	TDVM3-614	571	173	219		79	22.48	6.81	8.62		173.8
3.7	5	4	TDVM5-614	590	187	238		90	23.23	7.36	9.37		198.0
5.5	7.5	4	TDVM8-614	634	218	273		104	24.96	8.58	10.75		228.8
7.5	10	4	TDVM10-614	672	223	273		116	26.46	8.78	10.75		255.2

**TDVM-615**

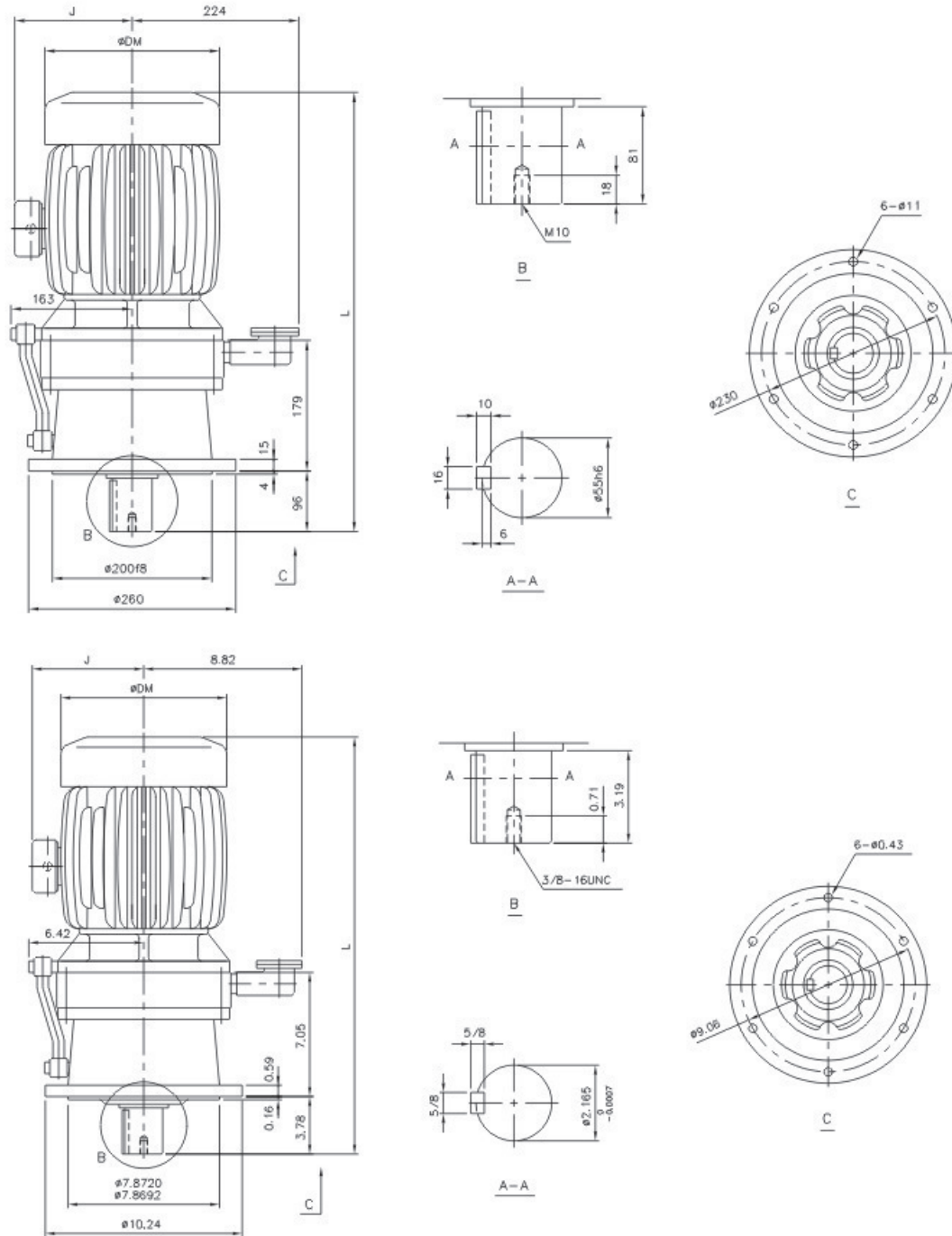

Motor			TRANSCYKO Model No.	Metric ( mm, kg )					Inches ( in.lbs )				
KW	HP	POLE		L	J	DM	H	Weight	L	J	DM	H	Weight
0.75	1	4	TDVM1-615	504	143	177		58	19.84	5.63	6.97		127.6
1.5	2	4	TDVM2-615	544	150	200		67	21.42	5.91	7.87		147.4
2.2	3	4	TDVM3-615	571	173	219		79	22.48	6.81	8.62		173.8
3.7	5	4	TDVM5-615	590	187	238		90	23.23	7.36	9.37		198.0
5.5	7.5	4	TDVM8-615	634	218	273		104	24.96	8.58	10.75		228.8
7.5	10	4	TDVM10-615	672	223	273		116	26.46	8.78	10.75		255.2
11	15	4	TDVM15-615	752	256	334		142	29.61	10.08	13.15		312.4

**TDVM-616**

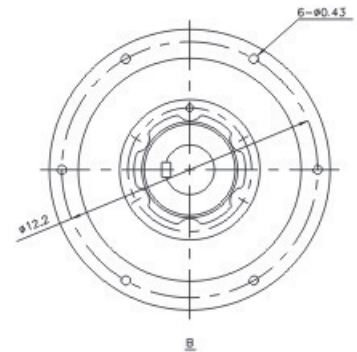
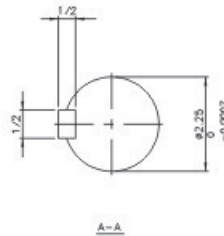
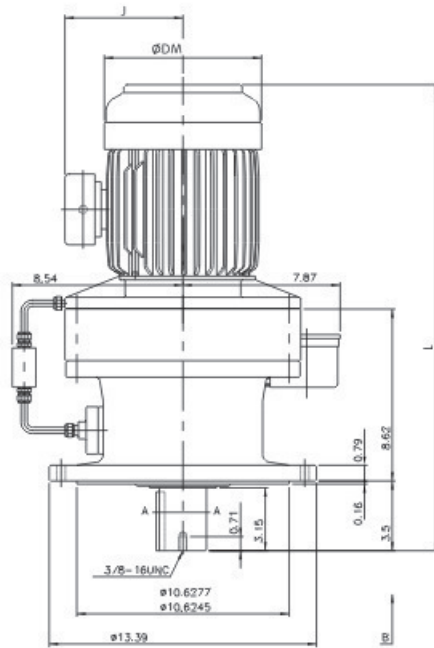
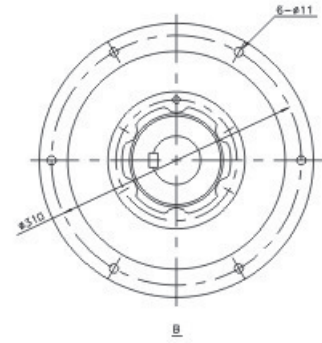
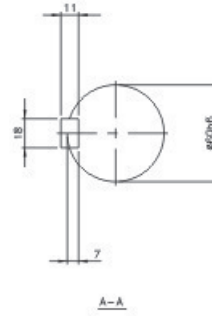
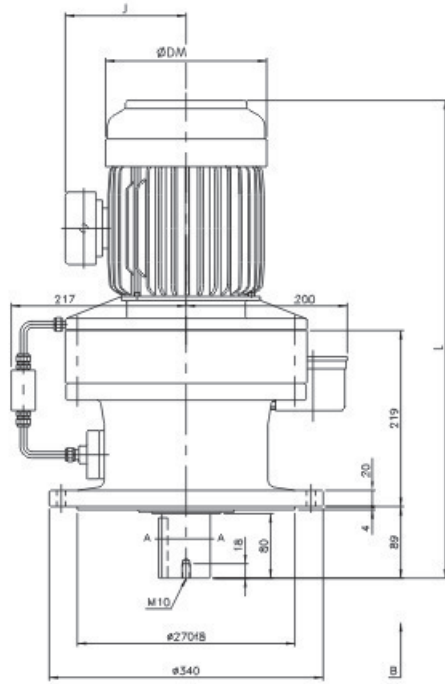

Motor			TRANSCYKO Model No.	Metric ( mm, kg )					Inches ( in.lbs )				
KW	HP	POLE		L	J	DM	H	Weight	L	J	DM	H	Weight
1.5	2	4	TDVM2-616	593	150	200		103	23.35	5.91	7.87		226.6
2.2	3	4	TDVM3-616	622	173	219		115	24.49	6.81	8.62		253.0
3.7	5	4	TDVM5-616	641	187	238		125	25.24	7.36	9.37		275.0
5.5	7.5	4	TDVM8-616	675	218	273		140	26.57	8.58	10.75		308.0
7.5	10	4	TDVM10-616	713	223	273		152	28.07	8.87	10.75		334.2
11	15	4	TDVM15-616	800	256	334		174	31.05	10.08	13.15		382.8
15	20	4	TDVM20-616	844	256	334		191	33.23	10.08	13.15		420.2



**TDVM-617**

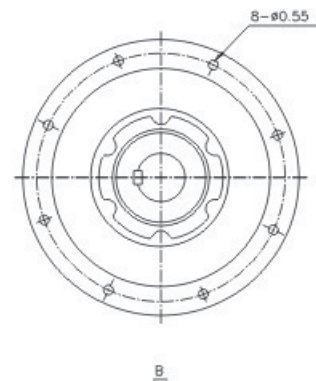
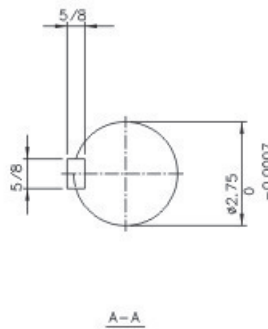
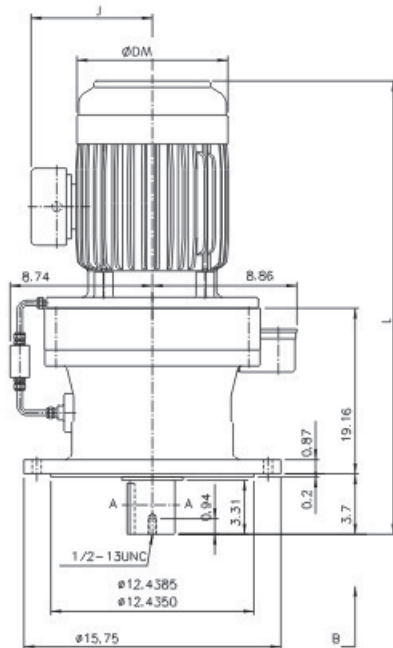
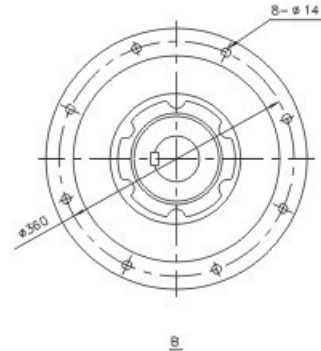
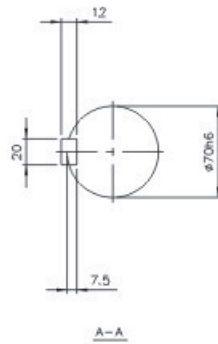
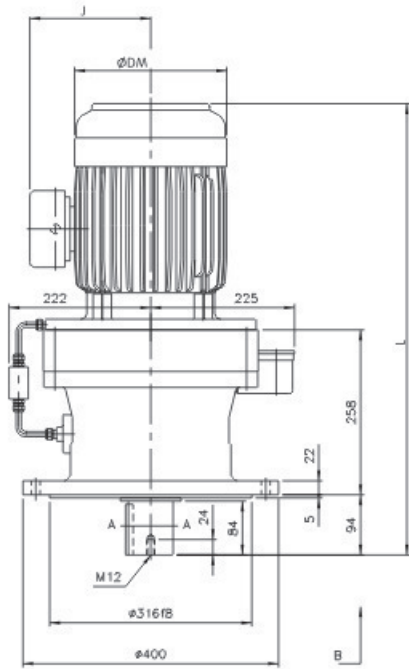

Motor			TRANSCYKO Model No.	Metric ( mm, kg )					Inches ( in.lbs )				
KW	HP	POLE		L	J	DM	H	Weight	L	J	DM	H	Weight
3.7	5	4	TDVM5-617	697	182	238		170	27.44	7.17	9.37		374.0
5.5	7.5	4	TDVM8-617	731	218	273		185	28.78	8.58	10.75		407.0
7.5	10	4	TDVM10-617	769	218	273		198	30.28	8.78	10.75		435.6
11	15	4	TDVM15-617	844	256	334		199	33.23	10.08	13.15		437.8
15	20	4	TDVM20-617	888	256	334		234	34.96	10.08	13.15		514.8
18.5	25	4	TDVM25-617	911	305	382		301	35.87	12.01	15.04		662.2
22	30	4	TDVM30-617	911	305	382		301	35.87	12.01	15.04		662.2

**TDVM-618**

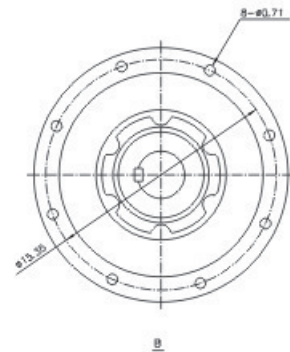
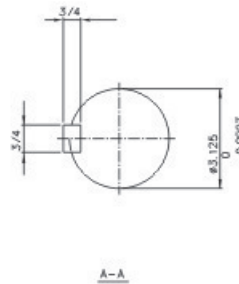
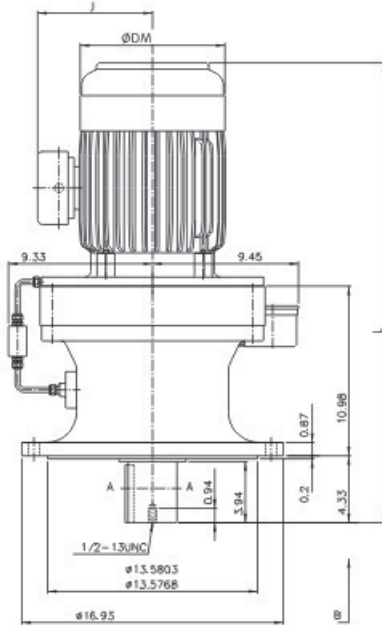
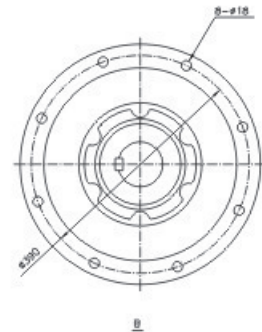
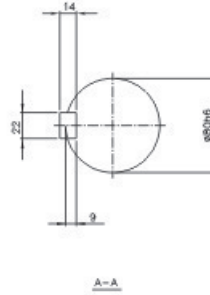
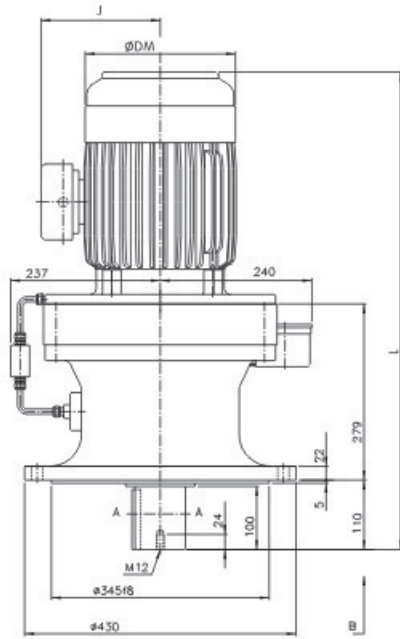

Motor			TRANSCYKO Model No.	Metric ( mm, kg )					Inches ( in.lbs )				
KW	HP	POLE		L	J	DM	H	Weight	L	J	DM	H	Weight
3.7	5	4	TDVM5-618	756	182	238		195	29.76	7.17	9.37		429.0
5.5	7.5	4	TDVM8-618	775	218	273		211	30.51	8.58	10.75		464.2
7.5	10	4	TDVM10-618	815	224	273		223	32.09	8.82	10.75		490.6
11	15	4	TDVM15-618	883	256	334		261	34.76	10.08	13.15		574.2
15	20	4	TDVM20-618	927	256	334		265	36.50	10.08	13.15		583.0
18.5	25	4	TDVM25-618	950	305	382		327	37.40	12.01	15.04		719.4
22	30	4	TDVM30-618	950	305	382		327	37.40	12.01	15.04		719.4
30	40	4	TDVM40-618	988	305	382		344	38.90	12.01	15.04		756.8

**TDVM-619**

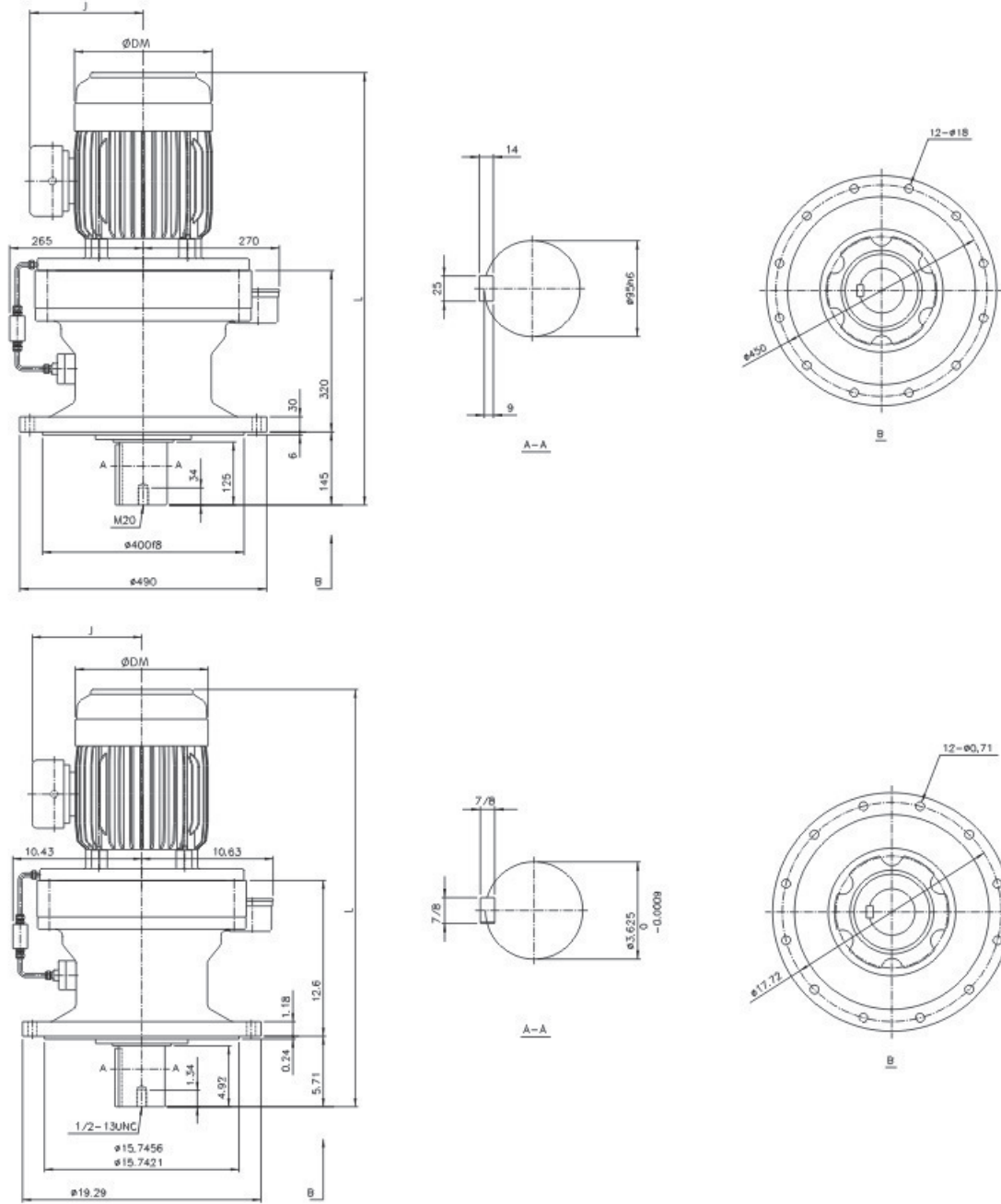

Motor			TRANSCYKO Model No.	Metric ( mm, kg )					Inches ( in.lbs )				
KW	HP	POLE		L	J	DM	H	Weight	L	J	DM	H	Weight
5.5	7.5	4	TDVM8-619	844	218	273		274	33.23	8.58	10.75		602.8
7.5	10	4	TDVM10-619	888	224	273		285	34.96	8.82	10.75		627.0
11	15	4	TDVM15-619	963	261	334		311	37.91	10.28	13.15		684.2
15	20	4	TDVM20-619	1007	261	334		330	39.65	10.28	13.15		726.0
18.5	25	4	TDVM25-619	1026	305	382		401	40.39	12.01	15.04		882.2
22	30	4	TDVM30-619	1026	305	382		401	40.39	12.01	15.04		882.2
30	40	4	TDVM40-619	1064	305	382		417	41.89	12.01	15.04		917.4
37	50	4	TDVM50-619	1127	339	420		452	44.37	13.35	16.54		994.4



**TDVM-620**

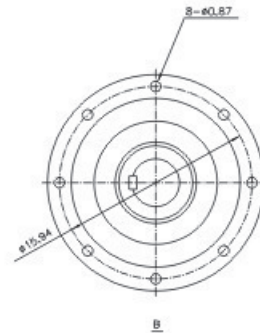
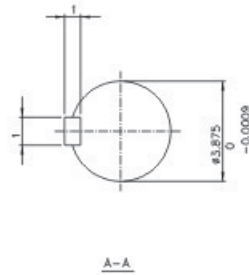
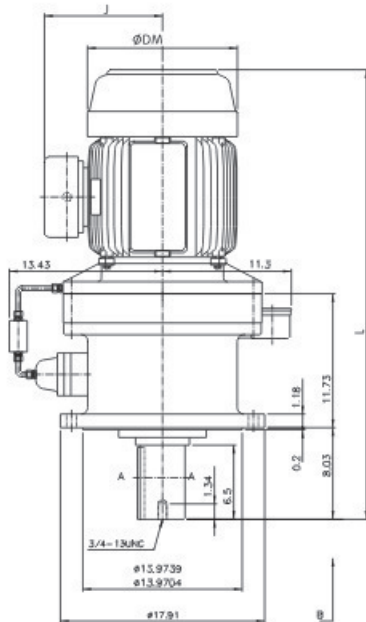
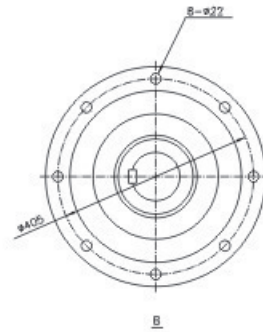
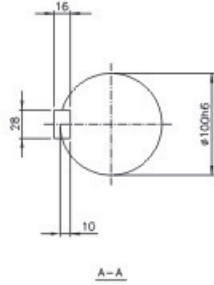
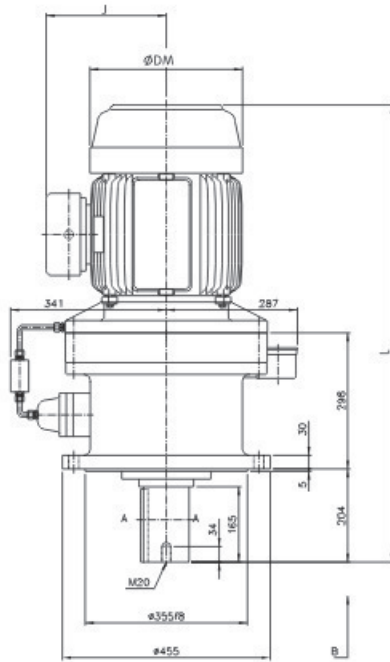

Motor			TRANSCYKO Model No.	Metric ( mm, kg )					Inches ( in.lbs )				
KW	HP	POLE		L	J	DM	H	Weight	L	J	DM	H	Weight
11	15	4	TDVM15-620	1001	261	334		334	39.41	10.28	13.15		734.8
15	20	4	TDVM15-620	1045	261	334		334	41.14	10.28	13.15		776.6
18.5	25	4	TDVM25-620	1064	305	382		382	41.89	12.01	15.04		928.4
22	30	4	TDVM30-620	1064	305	382		382	41.89	12.01	15.04		928.4
30	40	4	TDVM40-620	1102	305	382		382	43.39	12.01	15.04		957.0
37	50	4	TDVM50-620	1165	339	420		420	45.87	13.35	16.54		1085
45	60	4	TDVM60-620	1165	339	420		420	45.87	13.35	16.54		1085

**TDVM-621**

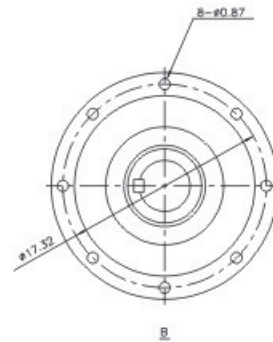
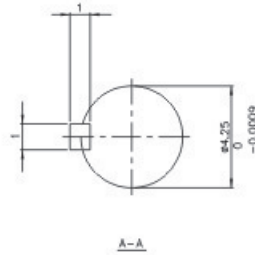
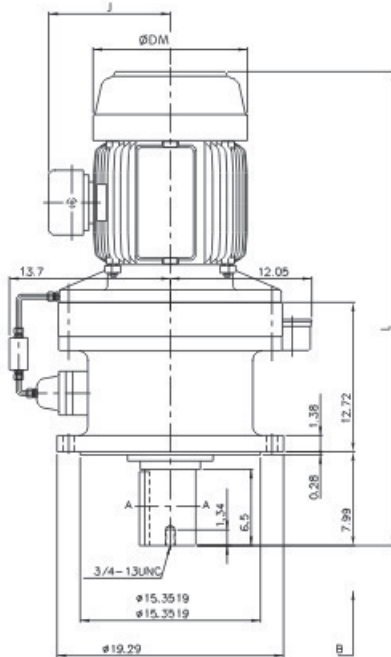
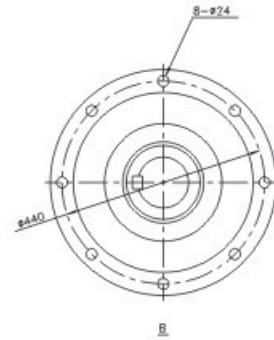
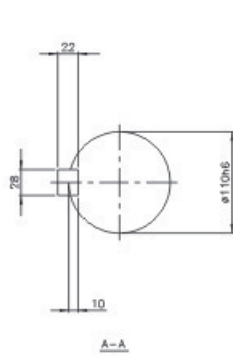
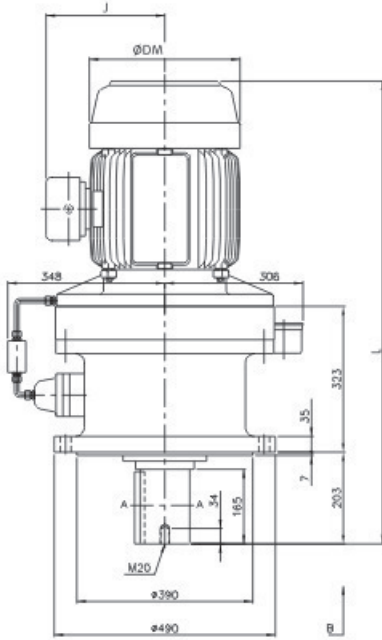

Motor			TRANSCYKO Model No.	Metric ( mm, kg )					Inches ( in.lbs )				
KW	HP	POLE		L	J	DM	H	Weight	L	J	DM	H	Weight
11	15	4	TDVM115-621	1025	261	334		413	40.35	10.28	13.15		908.6
15	20	4	TDVM120-621	1069	261	334		432	42.09	10.28	13.15		950.4
18.5	25	4	TDVM125-621	1088	305	382		495	42.83	12.01	15.04		1089
22	30	4	TDVM130-621	1088	305	382		495	42.83	12.01	15.04		1089
30	40	4	TDVM140-621	1126	305	382		508	44.33	12.01	15.04		1118
37	50	4	TDVM150-621	1189	339	420		562	46.81	13.35	16.54		1236
45	60	4	TDVM160-621	1189	339	420		562	46.81	13.35	16.54		1236
55	75	4	TDVM175-621	1227	387	458		655	48.31	15.24	18.03		1441





TDVM-623

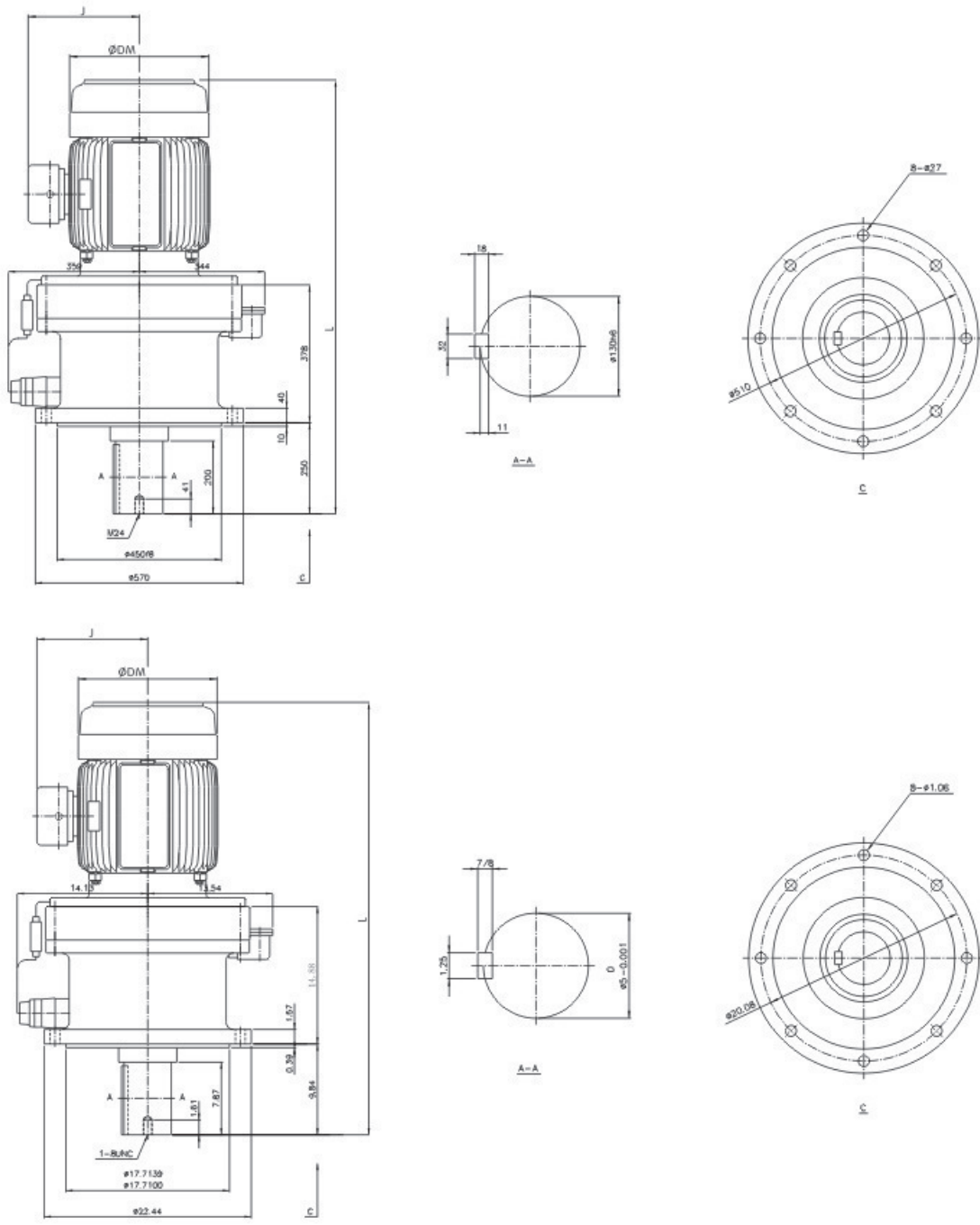

Motor			TRANSCYKO Model No.	Metric ( mm, kg )					Inches ( in.lbs )				
KW	HP	POLE		L	J	DM	H	Weight	L	J	DM	H	Weight
15	20	6	TDVM20/6-623	1200	305	382		647	47.24	12.01	15.04		1423
18.5	25	6	TDVM25/6-623	1238	305	382		665	48.74	12.01	15.04		1423
22	30	6	TDVM30/6-623	1238	305	382		665	48.74	12.01	15.04		1463
30	40	6	TDVM20/6-623	1400	339	420		739	55.12	13.35	16.54		1626
37	50	6	TDVM50/6-623	1400	339	420		739	55.12	13.35	16.54		1626
45	60	6	TDVM60/6-623	1430	387	458		799	56.30	15.24	18.03		1758
55	75	6	TDVM70/6-623	1492	515	542		854	58.74	20.28	21.34		1879



**TDVM-625**

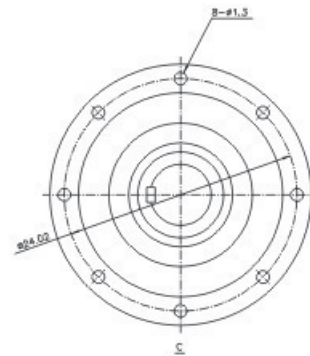
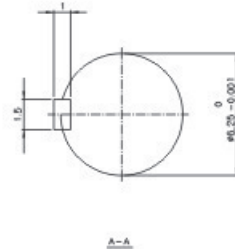
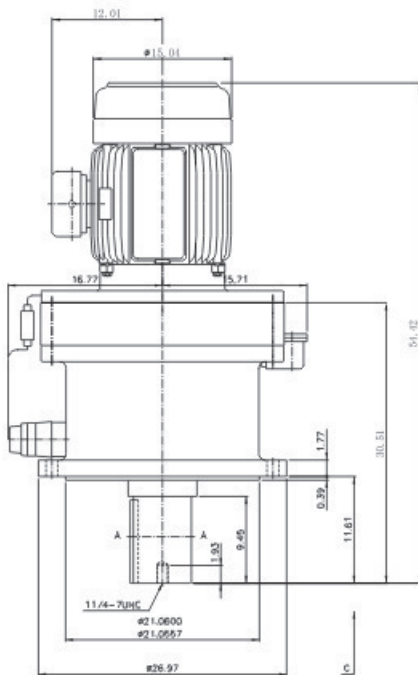
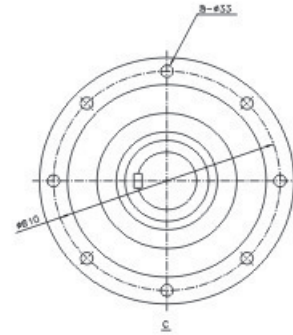
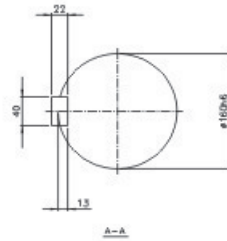
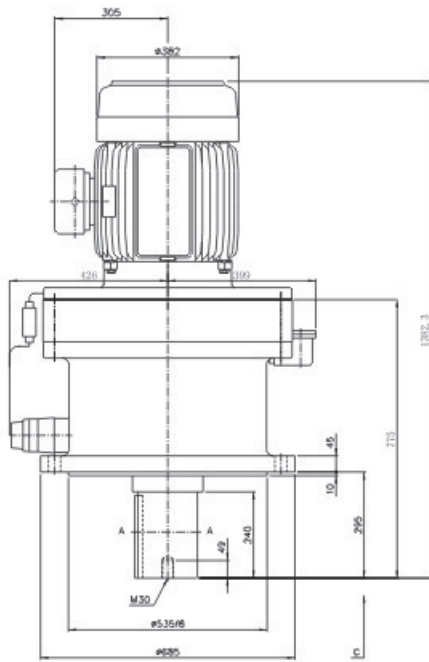

Motor			TRANSCYKO Model No.	Metric ( mm, kg )					Inches ( in.lbs )				
KW	HP	POLE		L	J	DM	H	Weight	L	J	DM	H	Weight
18.5	25	6	TDVM25/6-625	1390	305	382		1059	54.72	12.01	15.04		2330
22	30	6	TDVM30/6-625	1390	305	382		1059	54.72	12.01	15.04		2330
30	40	6	TDVM40/6-625	1453	339	420		1138	57.20	13.35	16.54		2504
37	50	6	TDVM50/6-625	1453	339	420		1138	57.20	13.35	16.54		2504
45	60	6	TDVM60/6-625	1491	387	458		1188	58.70	15.24	18.03		2614
55	75	6	TDVM75/6-625	1540	515	542		1239	60.63	20.28	21.34		2726



**TDVM-626**

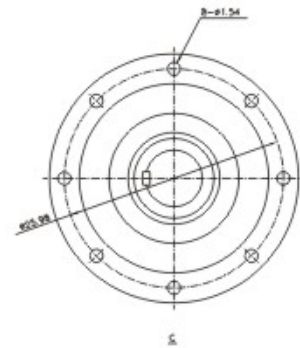
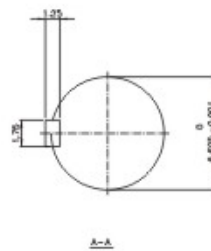
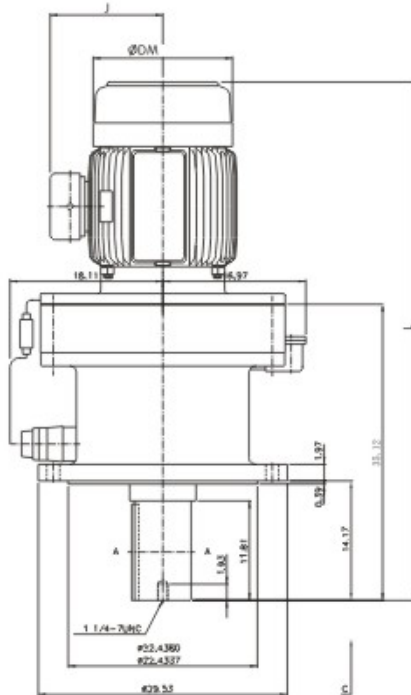
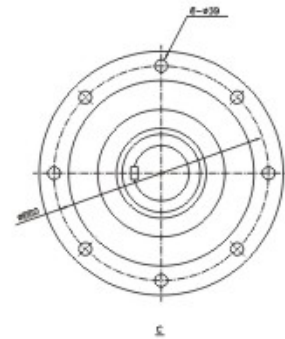
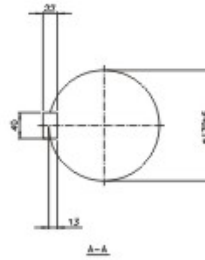
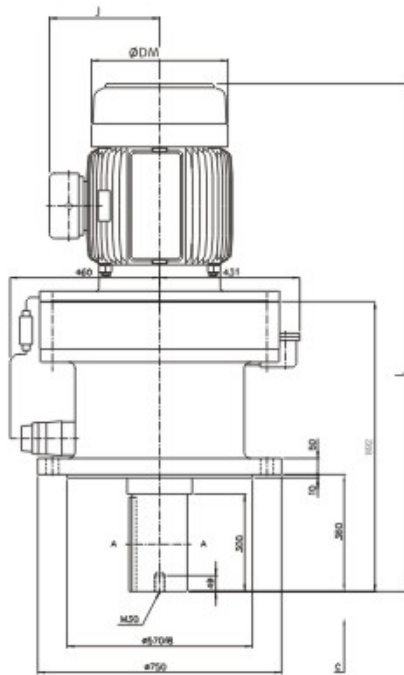

Motor			TRANSCYKO Model No.	Metric ( mm, kg )					Inches ( in.lbs )				
KW	HP	POLE		L	J	DM	H	Weight	L	J	DM	H	Weight
30	40	6	TDVM40/6-626	1570	339	420		1388	61.81	13.35	16.54		3054
37	50	6	TDVM50/6-626	1570	339	420		1388	61.81	13.35	16.54		3054
45	60	6	TDVM60/6-626	1608	387	458		1464	63.31	15.24	18.03		3221

# DIMENSION DRAWINGS

For Double Stage Reduction, Vertical TRANSCYKO Gearmotor

TVM-607/07

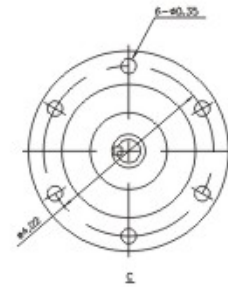
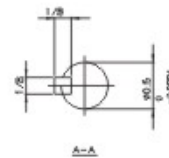
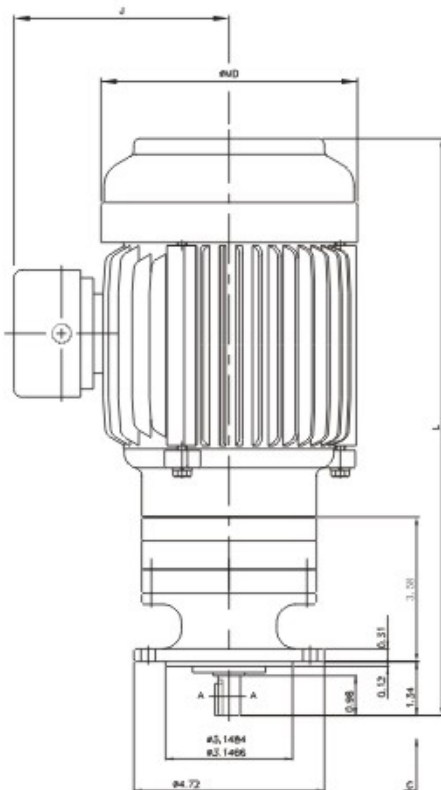
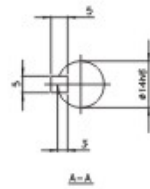
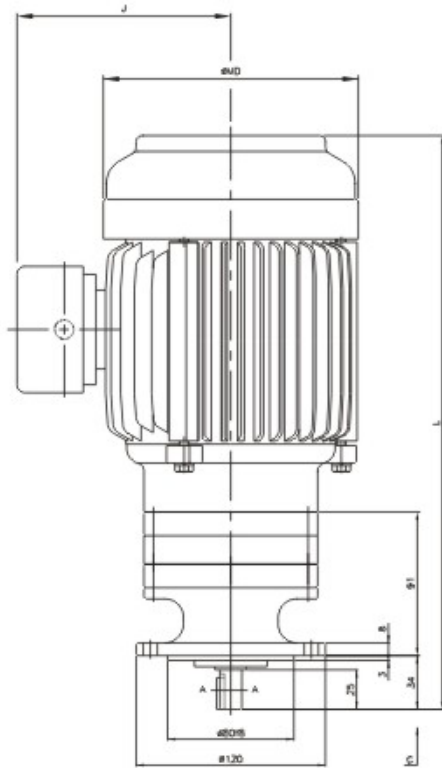

Motor			TRANSCYKO Model No.	Metric ( mm, kg )					Inches ( in.lbs )				
KW	HP	POLE		L	J	DM	H	Weight	L	J	DM	H	Weight
0.1	1/8	4	THM01-607/07	344	121	144		14	13.54	4.76	5.67		30.8

**TVM-608/07**

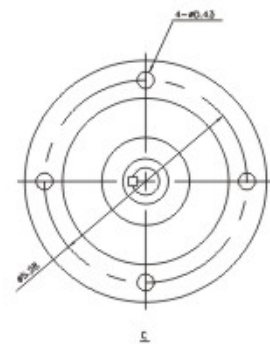
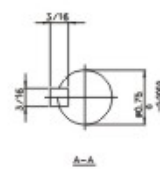
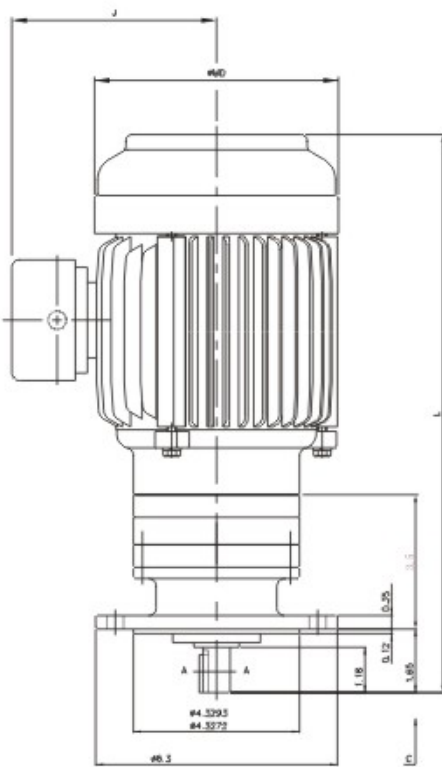
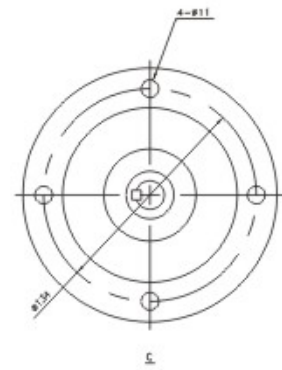
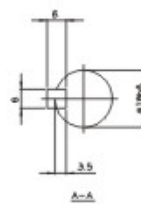
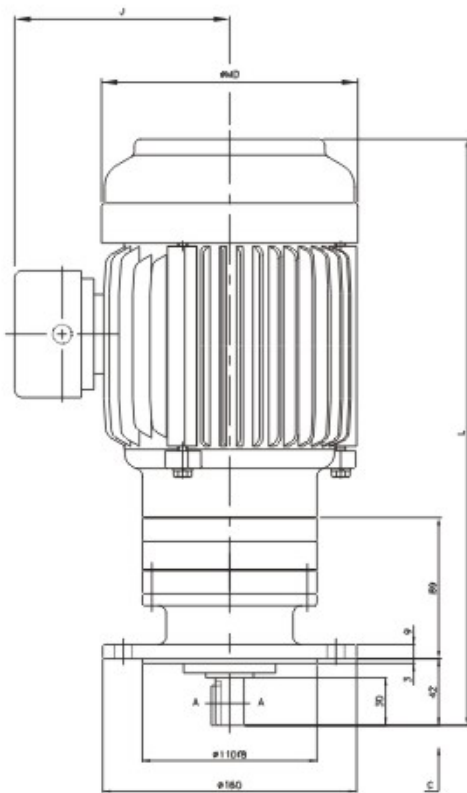

Motor			TRANSCYKO Model No.	Metric ( mm, kg )					Inches ( in.lbs )				
KW	HP	POLE		L	J	DM	H	Weight	L	J	DM	H	Weight
0.1	1/8	4	THM02-608/07	350	121	144		15	13.77	4.76	5.67		33



TVM-609/08

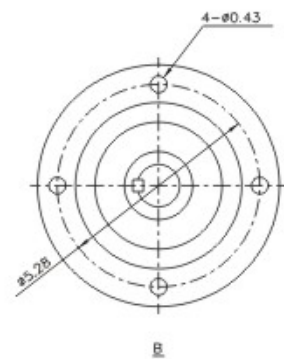
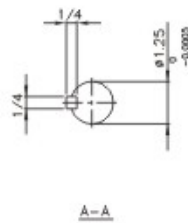
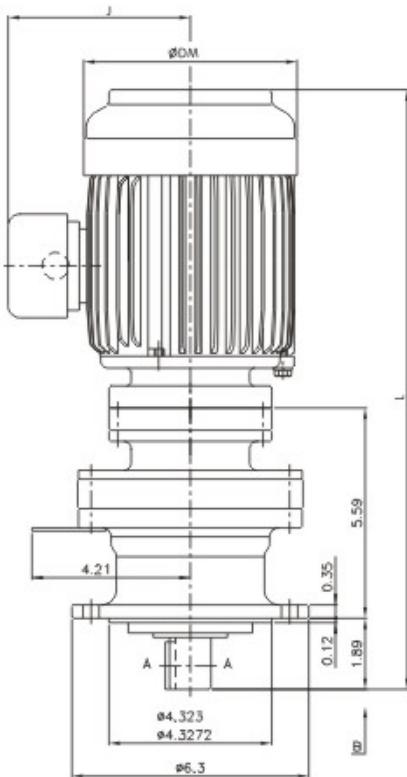
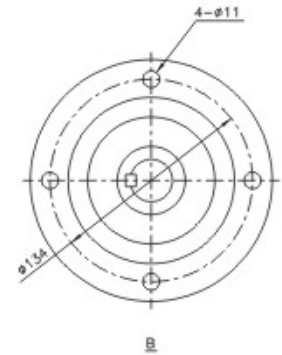
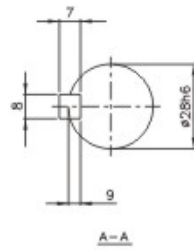
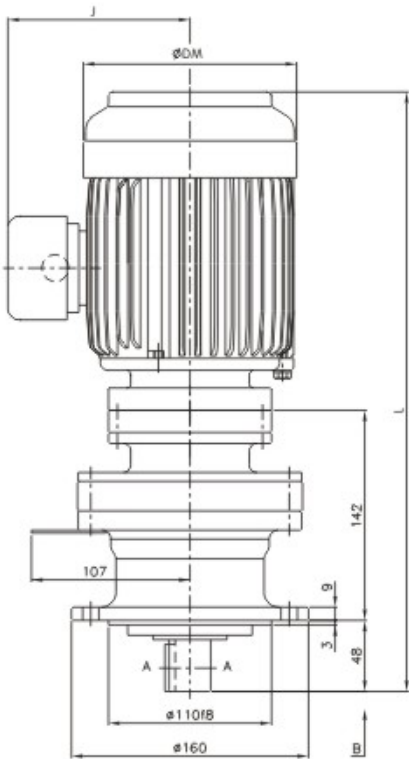

Motor			TRANSCYKO Model No.	Metric ( mm, kg )					Inches ( in.lbs )				
KW	HP	POLE		L	J	DM	H	Weight	L	J	DM	H	Weight
0.2	1/4	4	TVM02-609/08	409	121	144		21	16.10	4.76	5.67		46.2

**TVM-610/08**

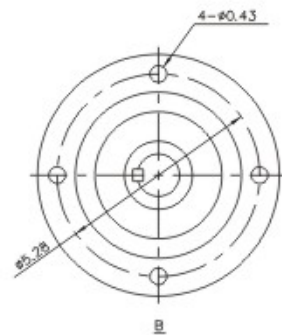
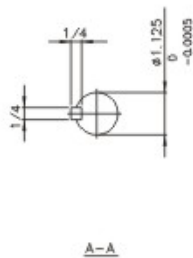
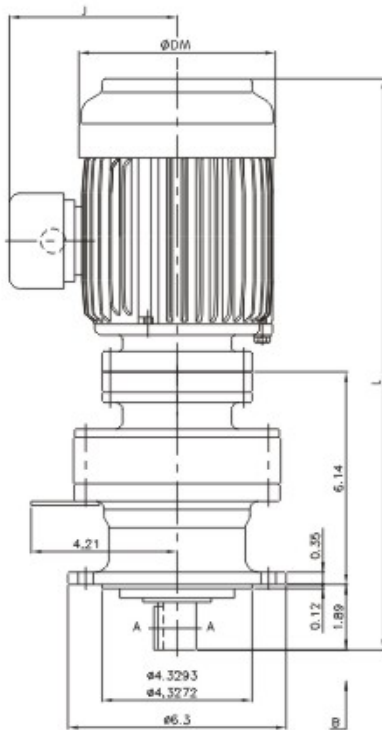
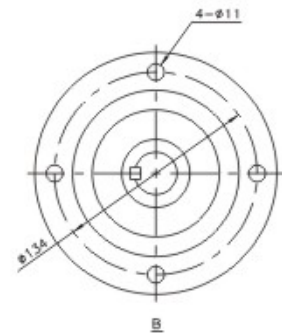
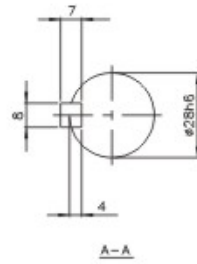
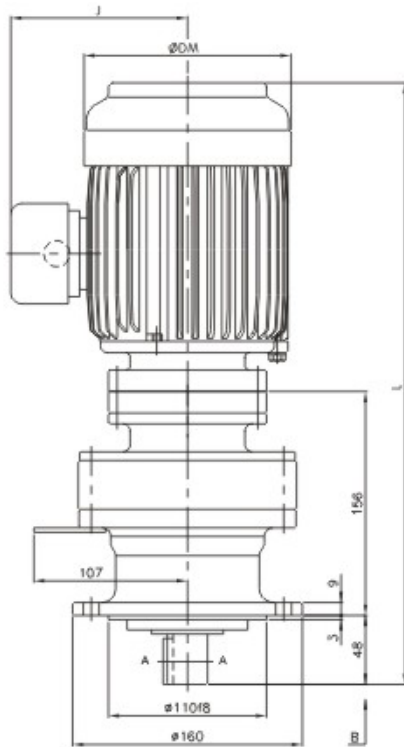

Motor			TRANSCYKO Model No.	Metric ( mm , kg )					Inches ( in.lbs )				
KW	HP	POLE		L	J	DM	H	Weight	L	J	DM	H	Weight
0.2	1/4	4	TVM02-610/08	433	121	144		22	16.65	4.76	5.67		48.4
0.4	1/2	4	TVM05-610/08	444	132	162		25	17.48	5.20	6.38		55.0

**TVM-611/08**

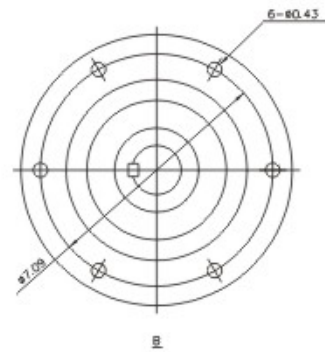
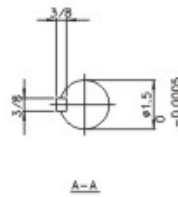
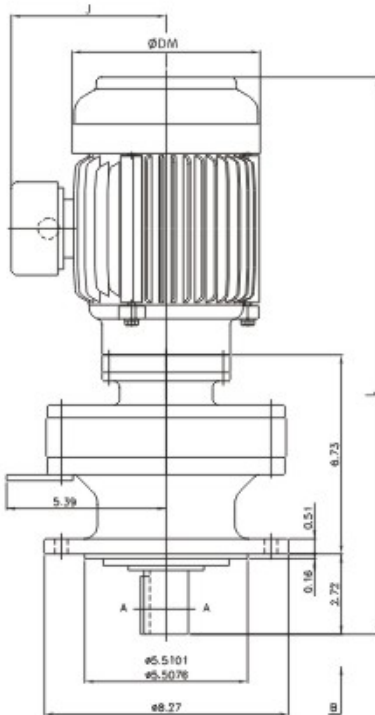
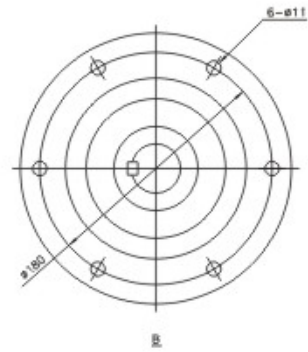
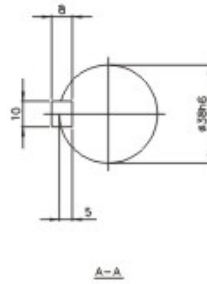
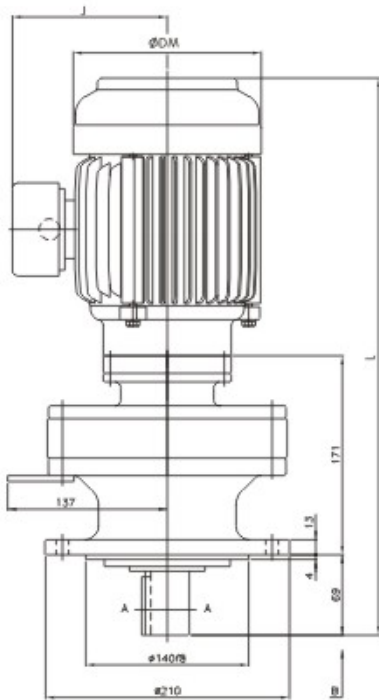

Motor			TRANSCYKO Model No.	Metric ( mm, kg )					Inches ( in.lbs )				
KW	HP	POLE		L	J	DM	H	Weight	L	J	DM	H	Weight
0.2	1/4	4	TVM02-611/08	459	121	144		33	17.13	4.76	5.67		726
0.4	1/2	4	TVM05-611/08	480	132	167		37	17.99	5.20	6.38		81.4



TVM-611/09

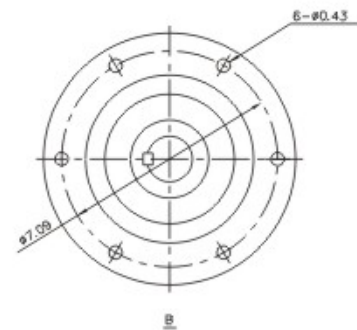
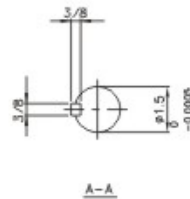
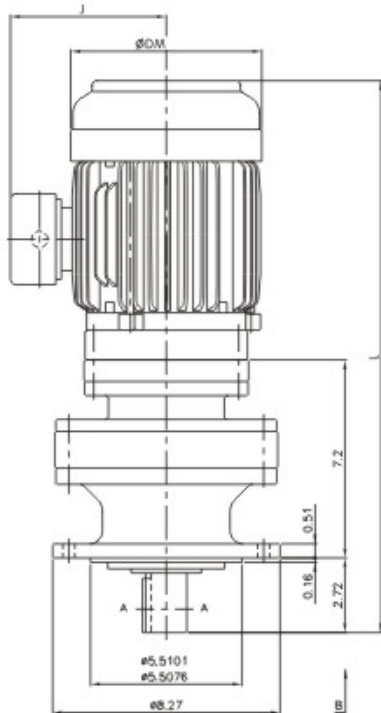
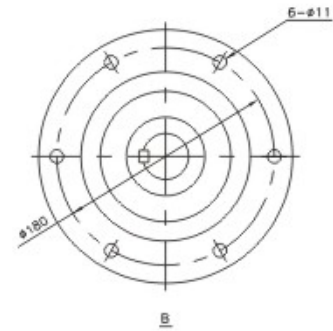
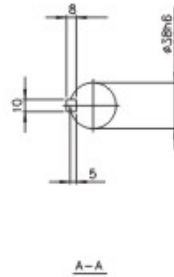
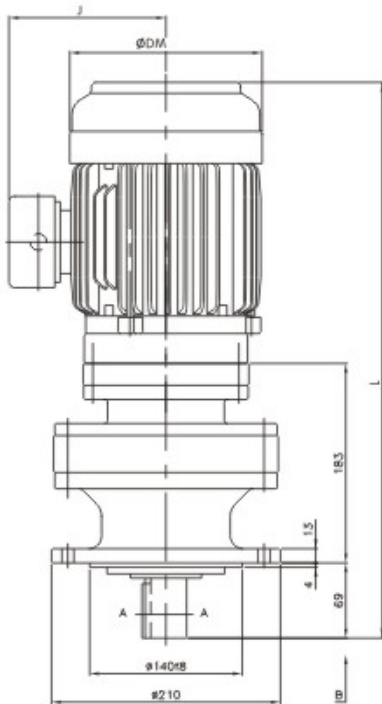

Motor			TRANSCYKO Model No.	Metric ( mm, kg )					Inches ( in.lbs )				
KW	HP	POLE		L	J	DM	H	Weight	L	J	DM	H	Weight
0.2	1/4	4	TVM02-611/09	471	121	144		39	18.54	4.76	5.67		85.8
0.4	1/2	4	TVM05-611/09	497	132	162		42	19.37	5.20	6.38		92.4
0.75	1	4	TVM1-611/09	491	137	177		44	19.33	5.39	6.97		96.8

**TDVM-613/08**

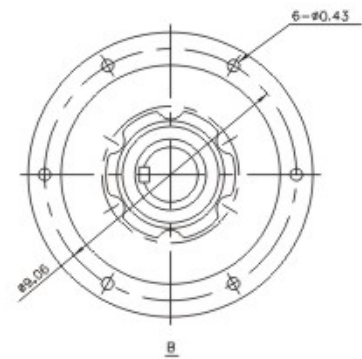
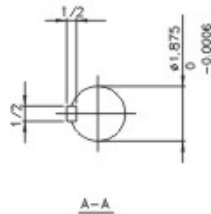
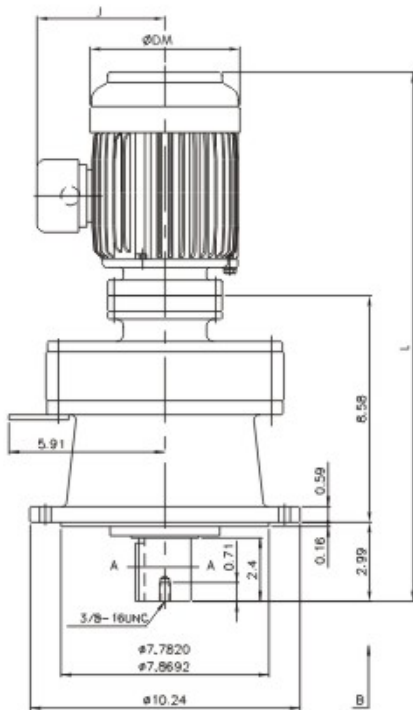
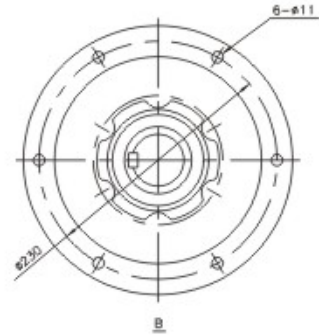
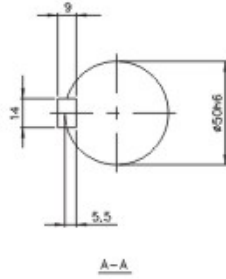
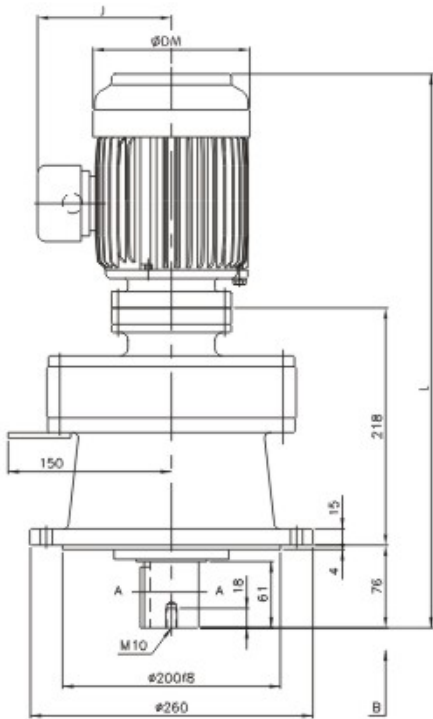

Motor			TRANSCYKO Model No.	Metric ( mm, kg )					Inches ( in.lbs )				
KW	HP	POLE		L	J	DM	H	Weight	L	J	DM	H	Weight
0.2	1/4	4	TDVM02-613/08	513	121	144		47	20.20	4.76	5.67		103.4
0.4	1/2	4	TDVM05-613/08	557	132	162		52	21.02	5.20	6.38		114.4

**TDVM-613/09**

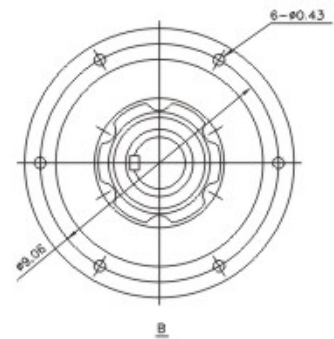
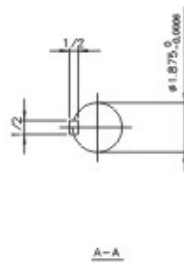
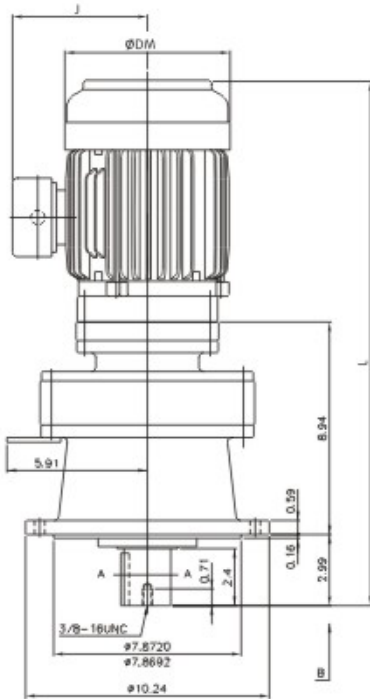
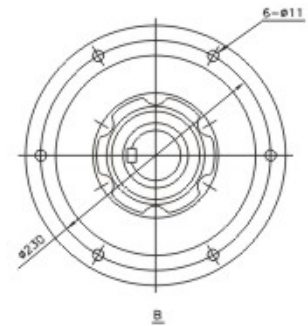
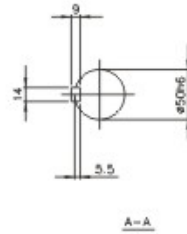
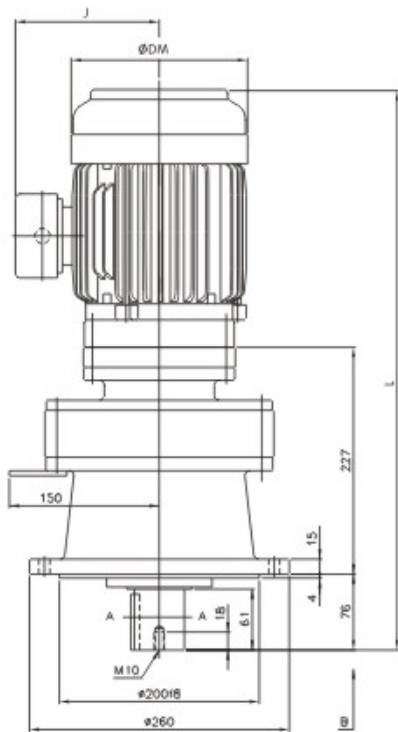

Motor			TRANSCYKO Model No.	Metric ( mm, kg )					Inches ( in.lbs )				
KW	HP	POLE		L	J	DM	H	Weight	L	J	DM	H	Weight
0.2	1/4	4	TDVM02-613/09	522	121	144		52	20.55	4.76	5.67		114.4
0.4	1/2	4	TDVM05-613/09	543	132	162		56	21.38	5.20	6.38		123.2
0.75	1	4	TDVM1-613/09	542	137	177		59	21.34	5.39	6.97		129.8



**TDVM-613/10**

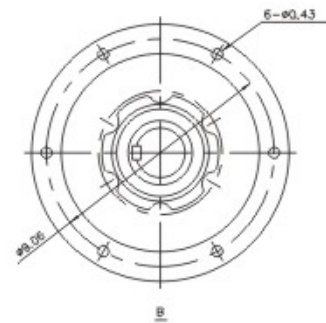
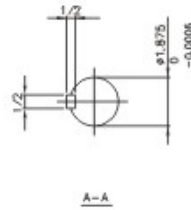
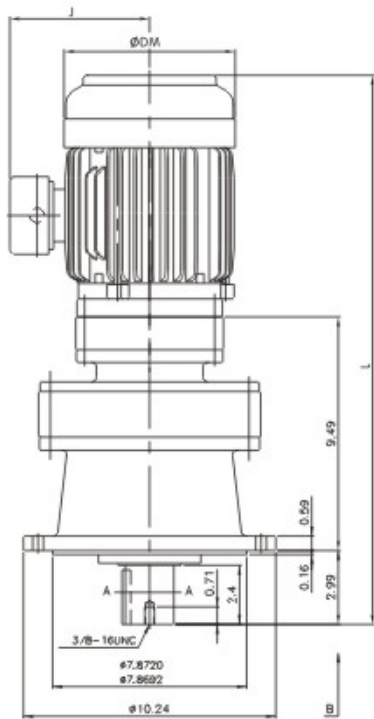
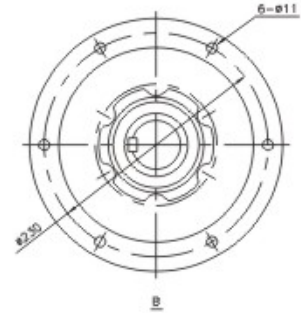
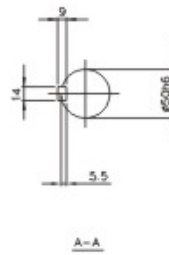
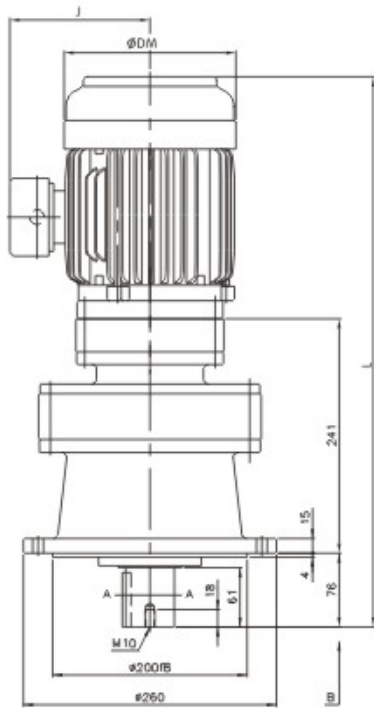

Motor			TRANSCYKO Model No.	Metric ( mm, kg )					Inches ( in.lbs )				
KW	HP	POLE		L	J	DM	H	Weight	L	J	DM	H	Weight
0.4	1/2	4	TDVM05-613/10	557	132	162		57	21.93	5.20	6.38		125.4
0.75	1	4	TDVM1-613/10	556	137	177		59	21.89	5.39	6.37		129.8
1.5	2	4	TDVM2-613/10	593	150	200		68	23.35	5.91	7.87		149.6
2.2	3	4	TDVM3-613/10	619	173	219		80	24.37	6.81	8.62		176.0

**TDVM-614/08**

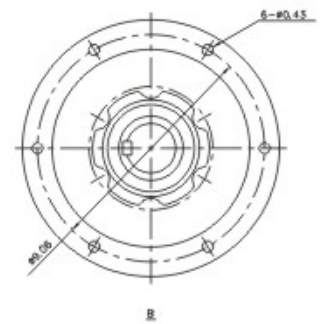
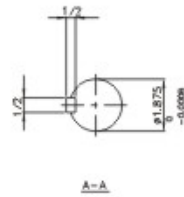
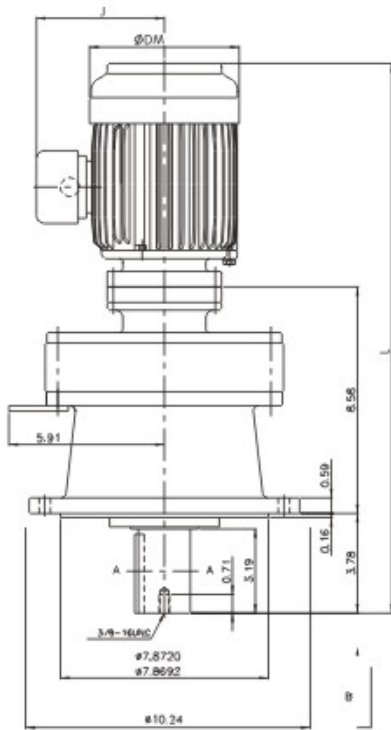
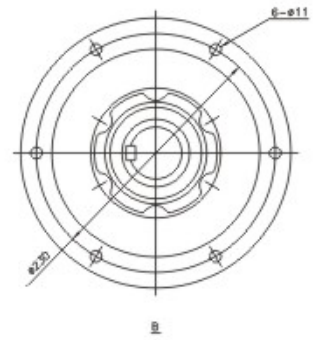
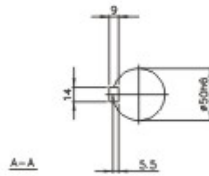
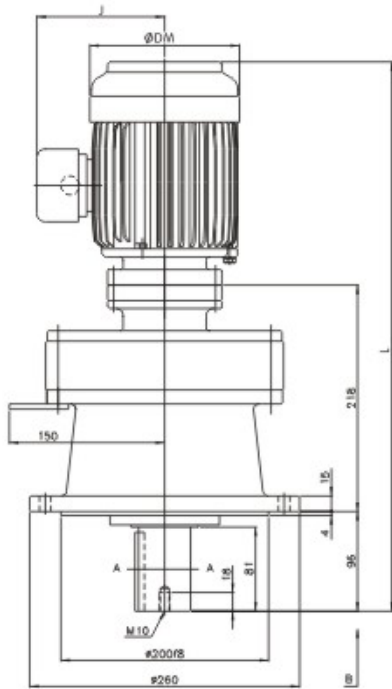

Motor			TRANSCYKO Model No.	Metric ( mm, kg )					Inches ( in.lbs )				
KW	HP	POLE		L	J	DM	H	Weight	L	J	DM	H	Weight
0.2	1/4	4	TDVM02-614/08	533	121	144		48	20.98	4.76	5.67		105.6
0.4	1/2	4	TDVM05-614/08	554	132	162		52	21.81	5.20	6.38		114.4

**TDVM-614/09**

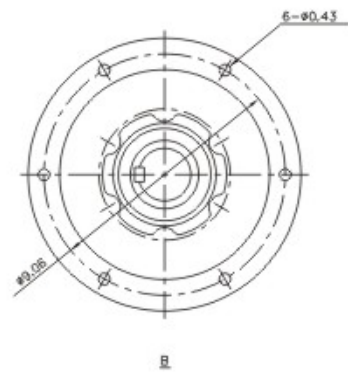
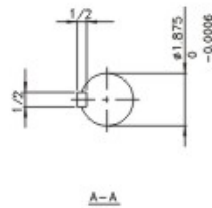
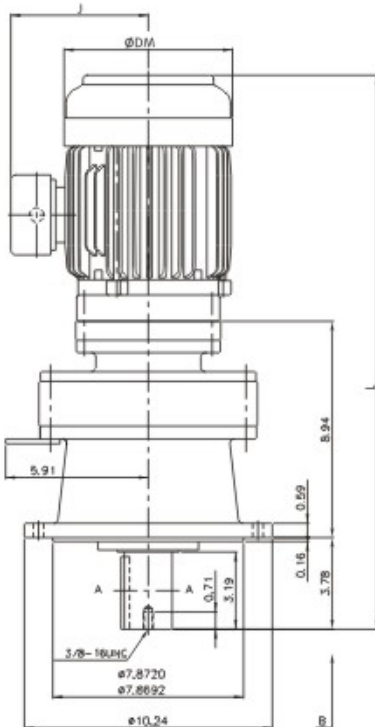
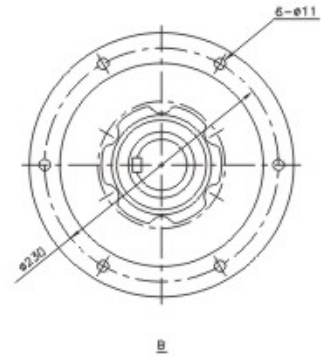
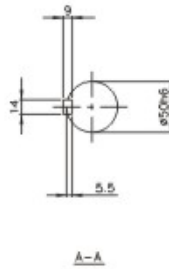
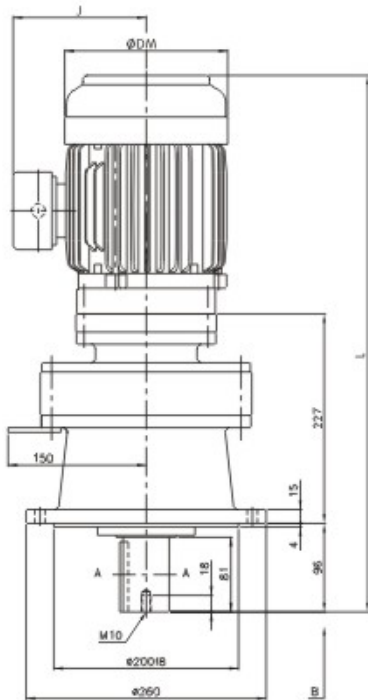

Motor			TRANSCYKO Model No.	Metric ( mm, kg )					Inches ( in.lbs )				
KW	HP	POLE		L	J	DM	H	Weight	L	J	DM	H	Weight
0.2	1/4	4	TDVM02-614/09	542	121	144		52	21.34	4.76	5.67		114.4
0.4	1/2	4	TDVM05-614/09	563	132	162		56	22.17	5.20	6.38		123.2
0.75	1	4	TDVM1-614/09	562	137	177		59	22.13	5.39	6.97		129.8



**TDVM-614/10**

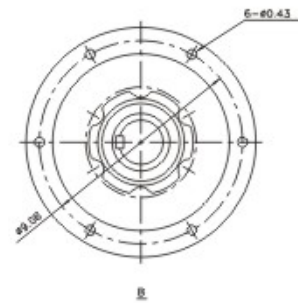
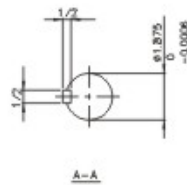
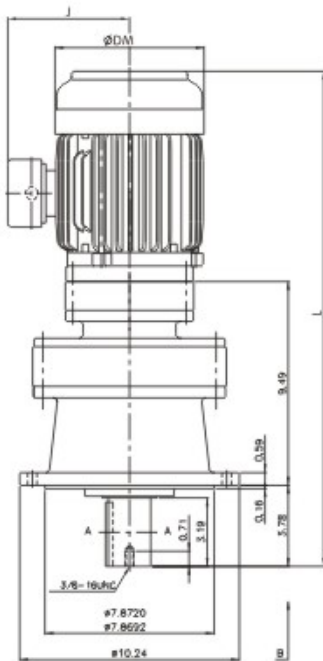
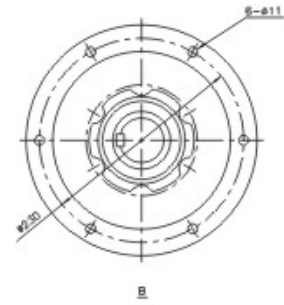
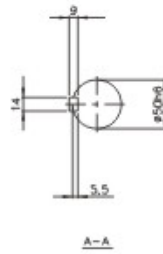
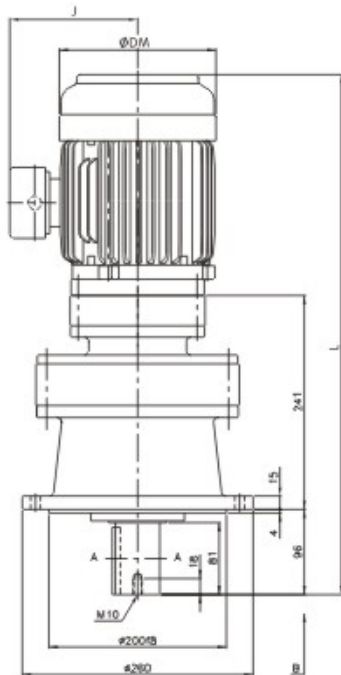

Motor			TRANSCYKO Model No.	Metric ( mm, kg )					Inches ( in.lbs )				
KW	HP	POLE		L	J	DM	H	Weight	L	J	DM	H	Weight
0.4	1/2	4	TDVM05-614/10	577	132	162		58	27.72	5.20	6.38		127.6
0.75	1	4	TDVM1-614/10	576	137	177		60	22.68	5.39	6.97		132.0
1.5	2	4	TDVM2-614/10	613	150	200		69	24.13	5.91	7.87		151.8
2.2	3	4	TDVM3-614/10	640	173	219		81	25.20	6.81	8.62		178.2

**TDVM-616/09**

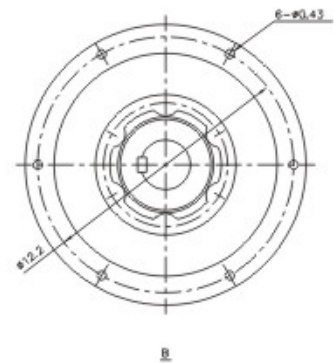
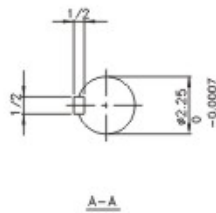
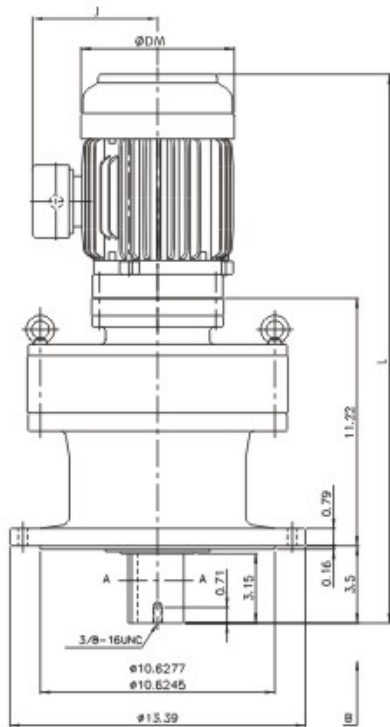
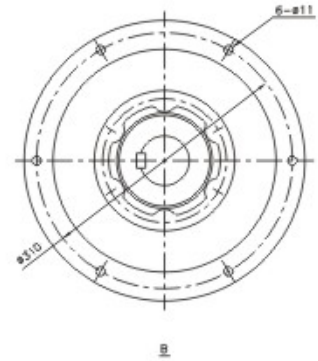
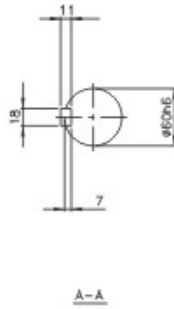
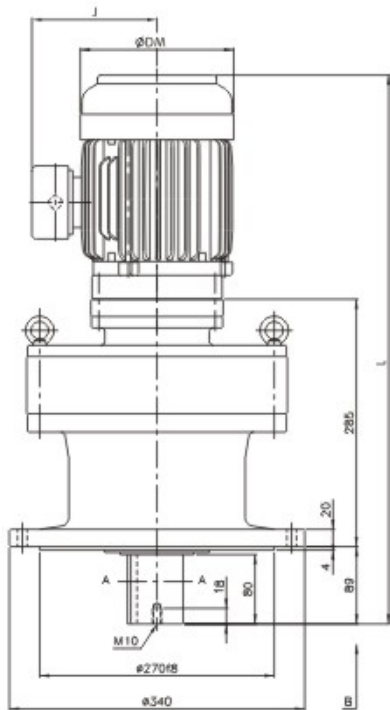

Motor			TRANSCYKO Model No.	Metric ( mm, kg )					Inches ( in.lbs )				
KW	HP	POLE		L	J	DM	H	Weight	L	J	DM	H	Weight
0.2	1/4	4	TDMM02-616/09	592	121	144		88	23.31	4.76	5.67		193.6
0.4	1/2	4	TDMM05-616/09	613	132	162		92	24.13	5.20	6.38		202.4
0.75	1	4	TDMM1-616/09	632	137	177		94	21.09	5.39	6.97		206.8

**TDVM-616/10**

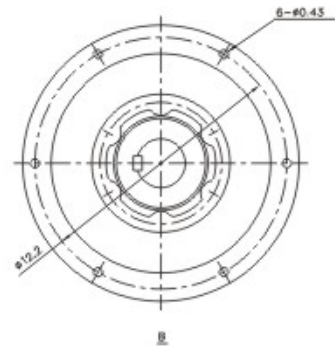
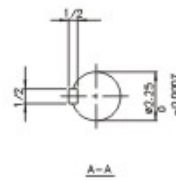
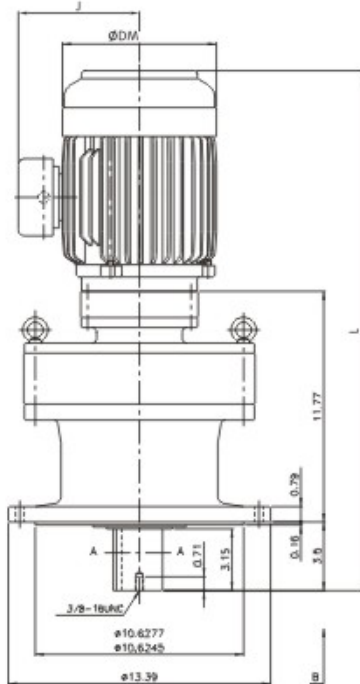
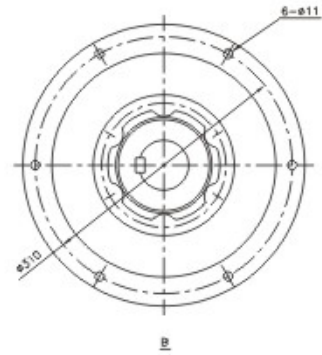
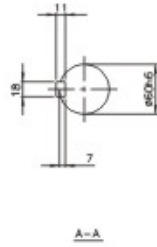
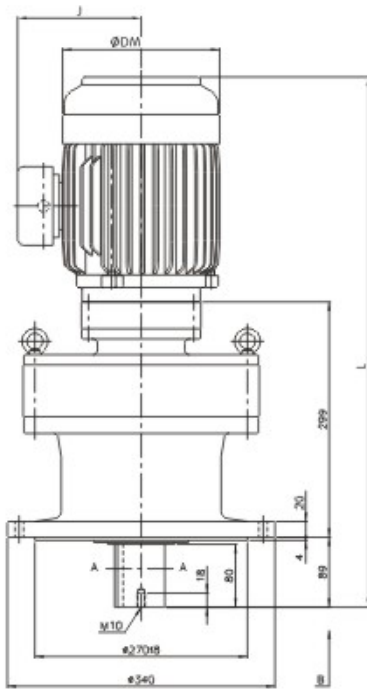

Motor			TRANSCYKO Model No.	Metric ( mm, kg )					Inches ( in.lbs )				
KW	HP	POLE		L	J	DM	H	Weight	L	J	DM	H	Weight
0.4	1/2	4	TDVM05-616/10	627	132	162		93	24.69	5.20	6.38		204.6
0.75	1	4	TDVM1-616/10	626	137	177		96	24.65	5.39	6.97		211.2
1.5	2	4	TDVM2-616/10	663	150	200		105	26.10	5.91	7.87		231.0
2.2	3	4	TDVM3-614/10	690	173	219		117	27.17	6.81	8.62		257.4





**TDVM-617/09**

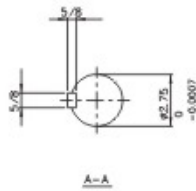
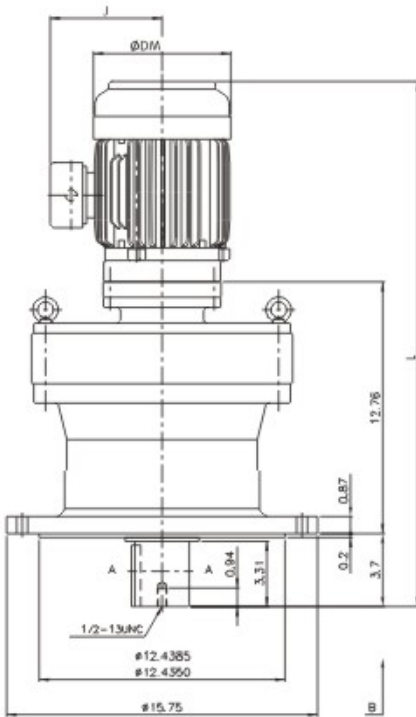
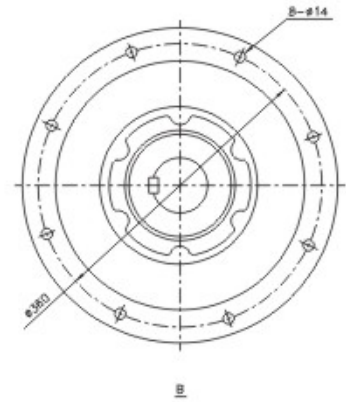
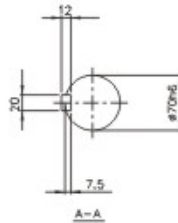
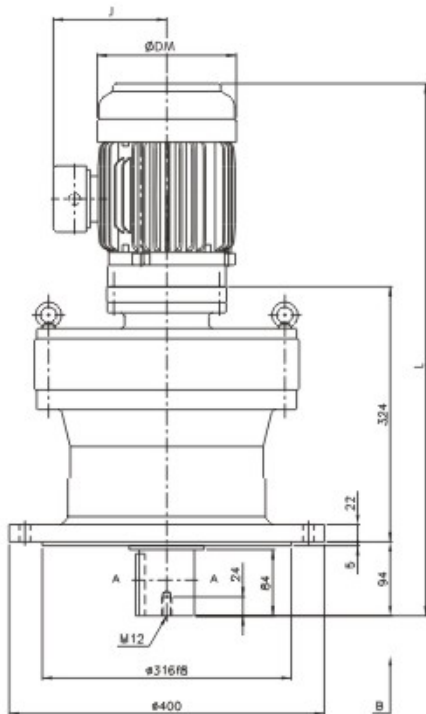

Motor			TRANSCYKO Model No.	Metric ( mm, kg )					Inches ( in.lbs )				
KW	HP	POLE		L	J	DM	H	Weight	L	J	DM	H	Weight
0.2	1/4	4	TDMM02-617/09	637	121	144		125	25.08	4.76	5.67		275.0
0.4	1/2	4	TDMM05-617/09	658	132	162		127	25.91	5.20	6.38		279.4
0.75	1	4	TDMM1-617/09	657	137	177		131	25.87	5.39	6.97		288.2

**TDVM-617/10**

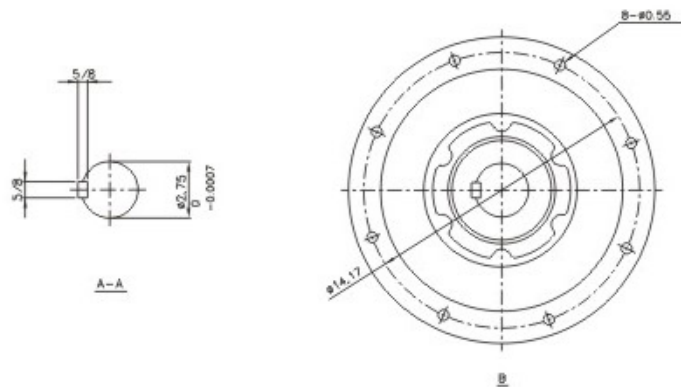
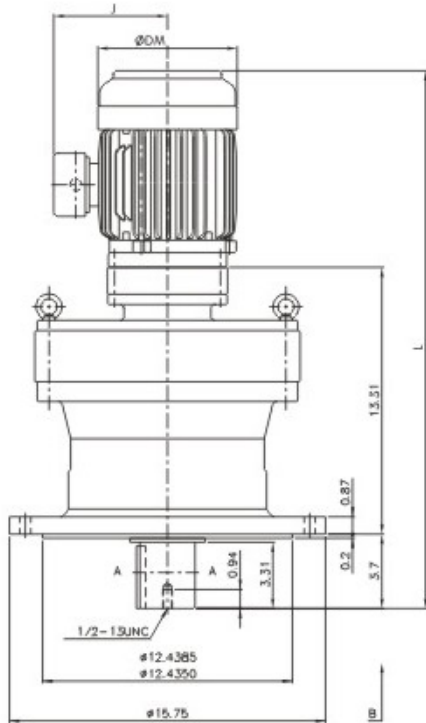
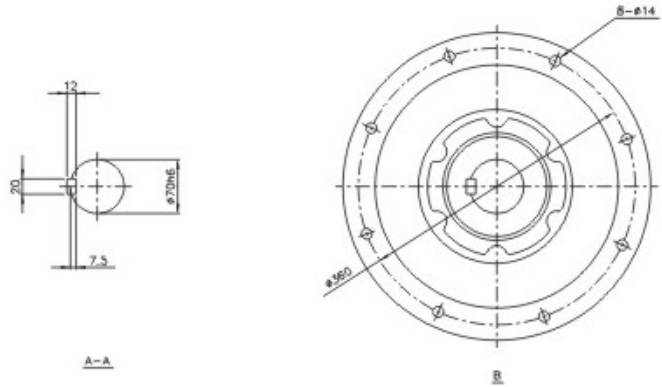
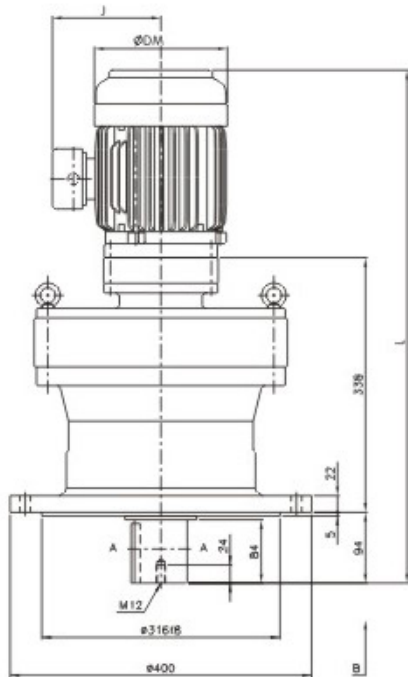

Motor			TRANSCYKO Model No.	Metric ( mm, kg )					Inches ( in.lbs )				
KW	HP	POLE		L	J	DM	H	Weight	L	J	DM	H	Weight
0.4	1/2	4	TDVM05-617/10	672	132	162		130	26.46	5.20	6.38		286.0
0.75	1	4	TDVM1-617/10	671	137	177		133	26.42	5.39	6.97		292.6
1.5	2	4	TDVM2-617/10	708	150	200		142	27.87	5.91	7.87		312.4
2.2	3	4	TDVM3-617/10	735	173	219		154	28.94	6.81	8.62		338.8



**TDVM-617/11**

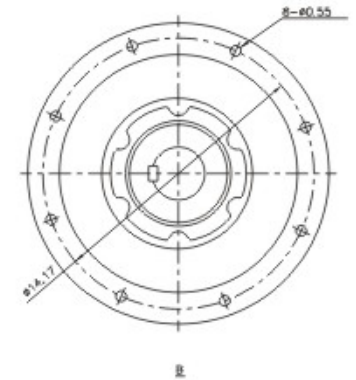
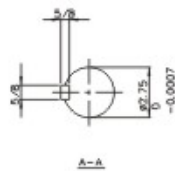
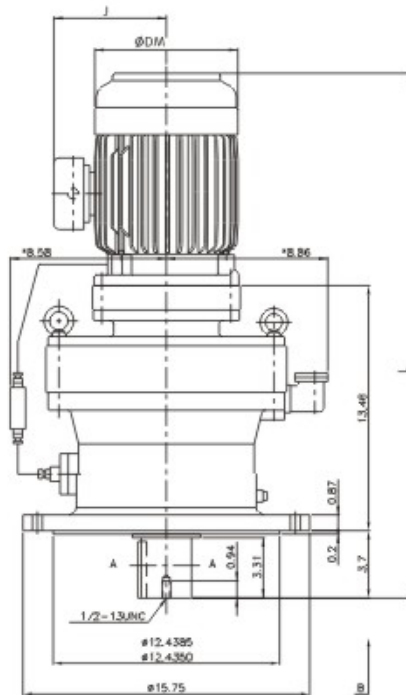
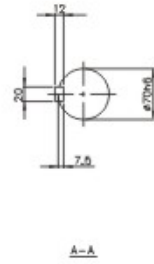
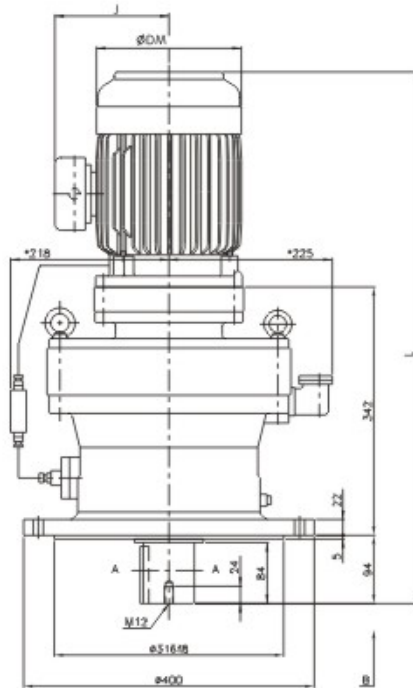

Motor			TRANSCYKO Model No.	Metric ( mm, kg )					Inches ( in.lbs )				
KW	HP	POLE		L	J	DM	H	Weight	L	J	DM	H	Weight
0.4	1/2	4	TDVM05-617/11	675	132	162		132	26.57	5.20	6.38		290.4
0.75	1	4	TDVM1-617/11	684	137	177		138	26.93	5.39	6.97		303.6
1.5	2	4	TDVM2-617/11	721	156	200		149	28.39	6.14	7.87		327.8
2.2	3	4	TDVM3-617/11	747	173	219		161	29.41	6.81	8.62		354.2
3.7	5	4	TDVM5-617/11	763	188	238		168	30.04	7.40	9.37		369.6

**TDVM-618/10**

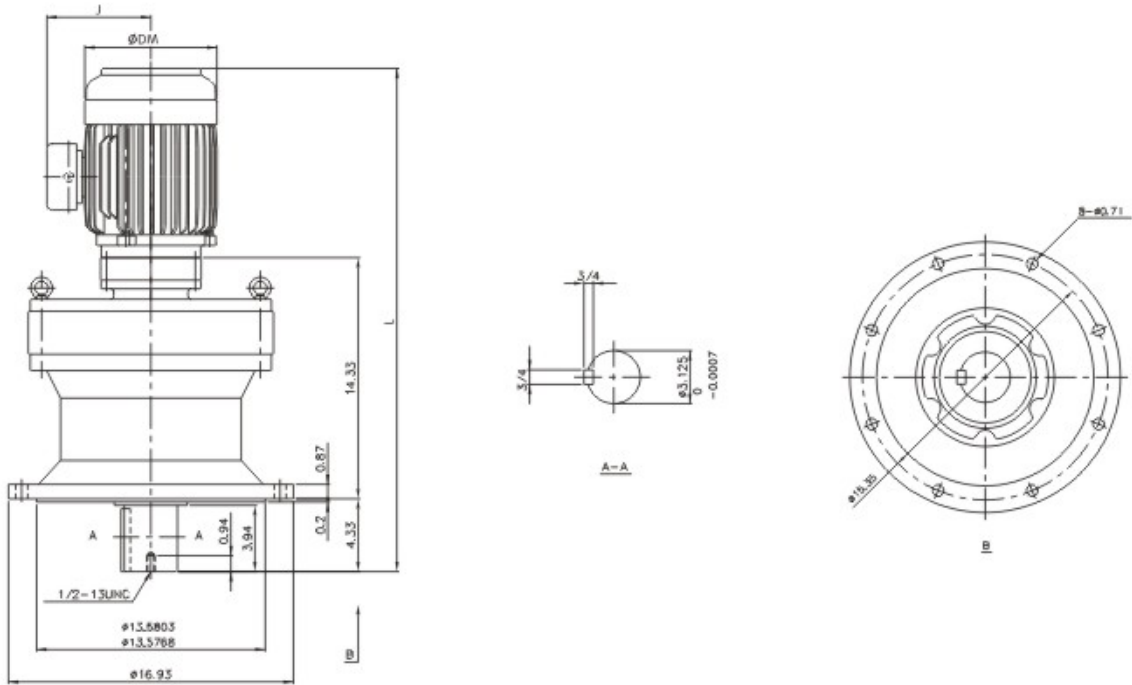
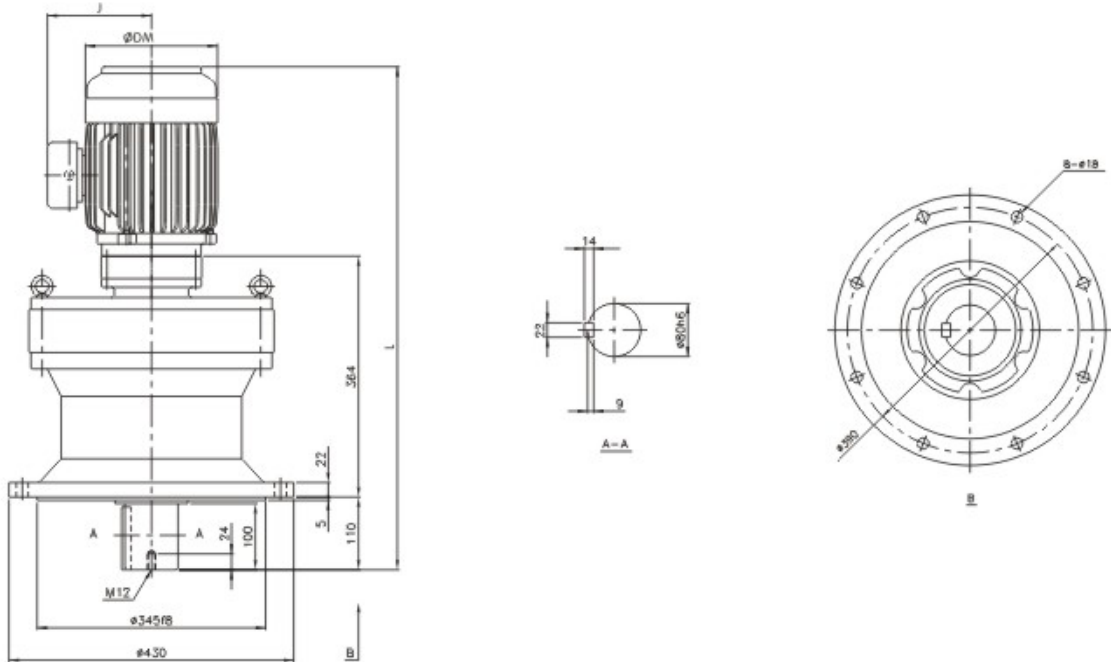

Motor			TRANSCYKO Model No.	Metric ( mm, kg )					Inches ( in.lbs )				
KW	HP	POLE		L	J	DM	H	Weight	L	J	DM	H	Weight
0.4	1/2	4	TDVM05-618/10	714	132	162		159	28.11	5.20	6.38		349.8
0.75	1	4	TDVM1-618/10	713	137	177		163	28.07	5.39	6.97		358.6
1.5	2	4	TDVM2-618/10	750	150	200		172	29.53	5.91	7.87		378.4
2.2	3	4	TDVM3-618/10		173	219		184	31.46	6.81	8.62		404.8

**TDVM-618/13**

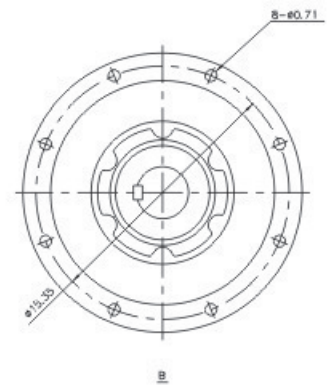
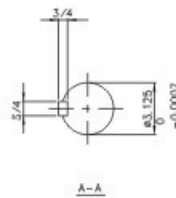
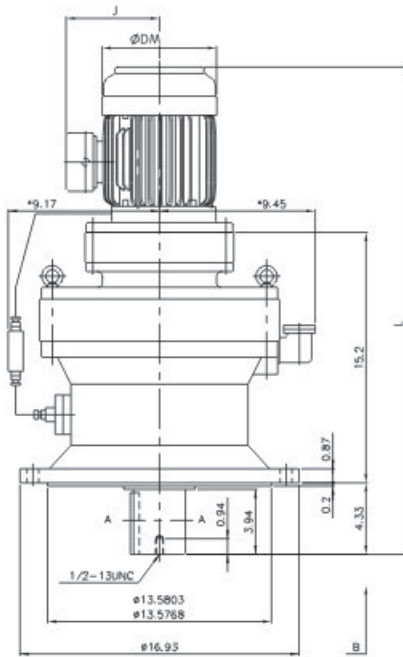
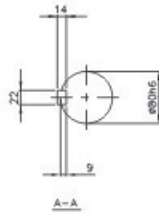
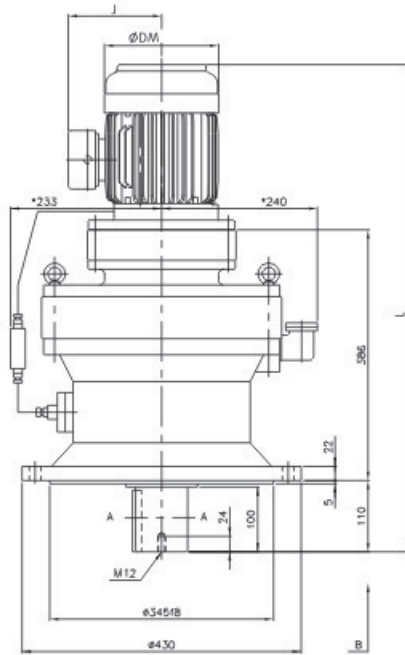

Motor			TRANSCYKO Model No.	Metric ( mm, kg )					Inches ( in.lbs )				
KW	HP	POLE		L	J	DM	H	Weight	L	J	DM	H	Weight
0.75	1	4	TDVM1-618/13	740	137	177		181	29.13	5.39	6.97		398.2
1.5	2	4	TDVM2-618/13	780	150	200		193	30.71	5.91	7.87		424.6
2.2	3	4	TDVM3-618/13	807	173	219		205	31.77	6.81	8.62		451.0
3.7	5	4	TDVM5-618/13	826	187	238		210	32.52	7.36	9.37		462.0
5.5	7.5	4	TDVM8-618/13	870	218	273		216	34.25	8.58	10.75		475.2
7.5	10	4	TDVM10-618/13	908	223	273		222	35.75	8.78	10.75		488.4



# TDVM-619/11

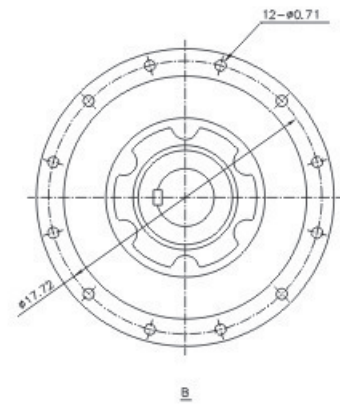
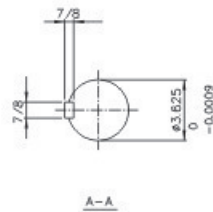
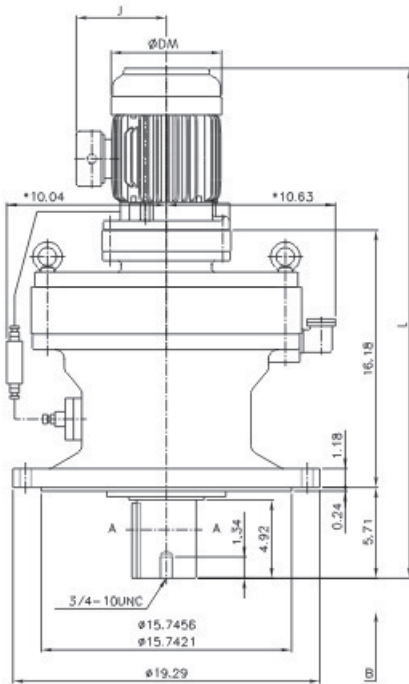
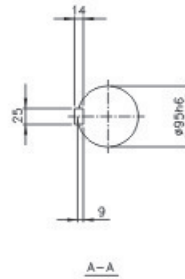
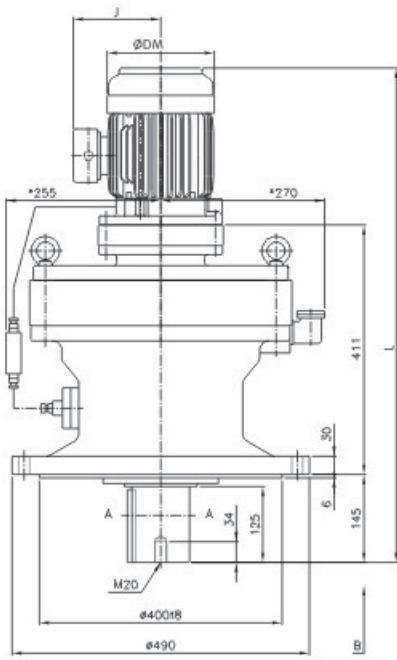

Motor			TRANSCYKO Model No.	Metric ( mm, kg )					Inches ( in.lbs )				
KW	HP	POLE		L	J	DM	H	Weight	L	J	DM	H	Weight
0.4		4	TDVM05-619/11	795	132	162		233	31.30	5.20	6.38		512.6
0.75	1	4	TDVM1-619/11	804	137	177		244	31.65	5.39	6.97		536.8
1.5	2	4	TDVM2-619/11	841	150	200		253	33.11	6.14	7.87		556.6
2.2	3	4	TDVM3-619/11	867	173	219		265	34.13	6.81	8.62		583.0
3.7	5	4	TDVM5-619/11	883	188	238		274	34.76	7.40	9.37		602.8

**TDVM-619/13**

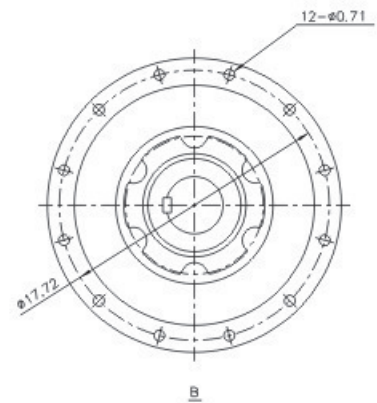
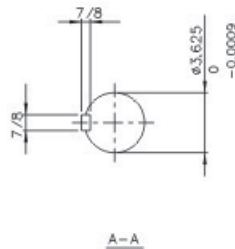
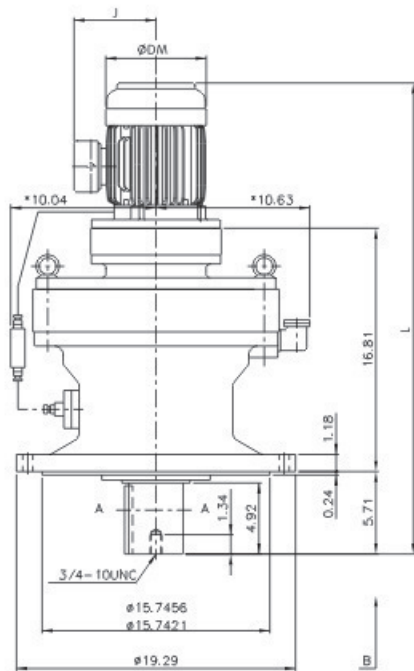
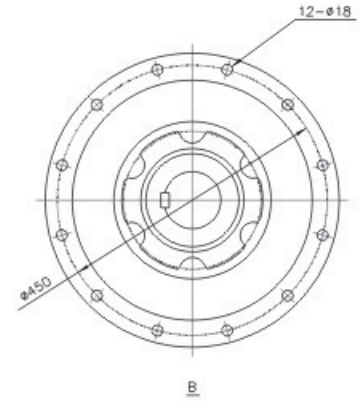
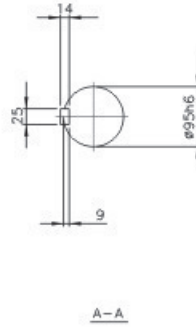
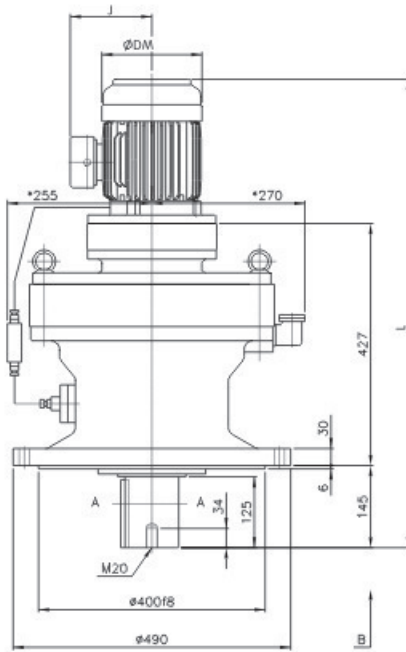

Motor			TRANSCYKO Model No.	Metric ( mm, kg )					Inches ( in.lbs )				
KW	HP	POLE		L	J	DM	H	Weight	L	J	DM	H	Weight
0.75	1	4	TDVM1-619/13	816	143	177		251	32.13	5.39	6.97		552.2
1.5	2	4	TDVM2-619/13	856	150	200		263	33.70	5.71	7.87		578.6
2.2	3	4	TDVM3-619/13	883	173	219		274	34.76	6.81	8.62		602.8
3.7	5	4	TDVM5-619/13	902	187	238		283	35.51	7.36	9.37		622.6
5.5	7.5	4	TDVM8-619/13	946	218	273		289	37.24	8.56	10.75		635.8
7.5	10	4	TDVM10-619/13	984	223	273		301	38.74	8.78	10.75		662.2

# TDVM-620/11

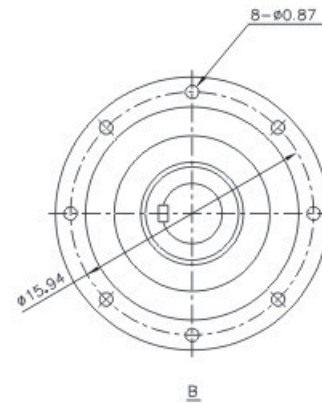
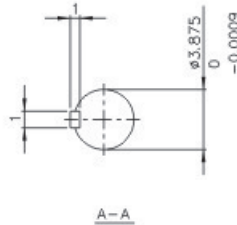
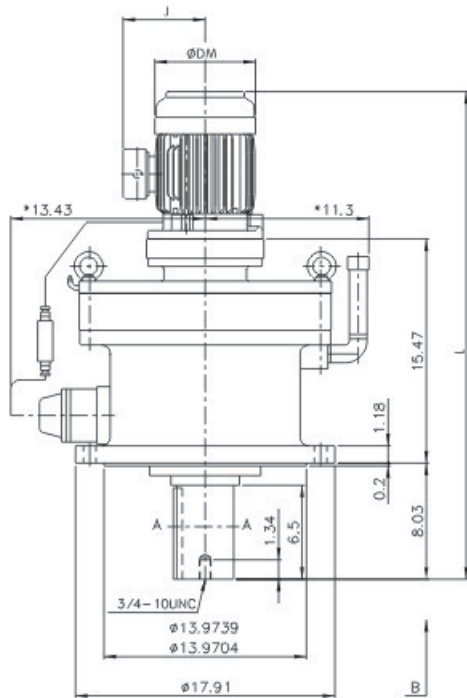
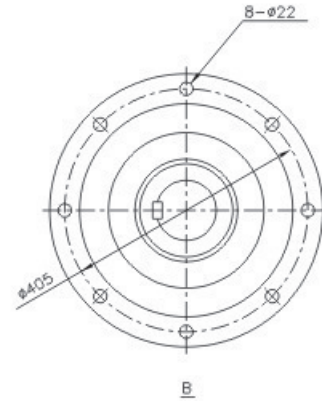
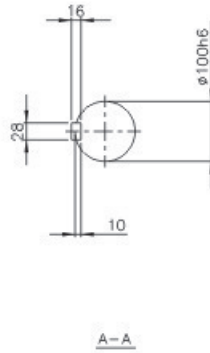
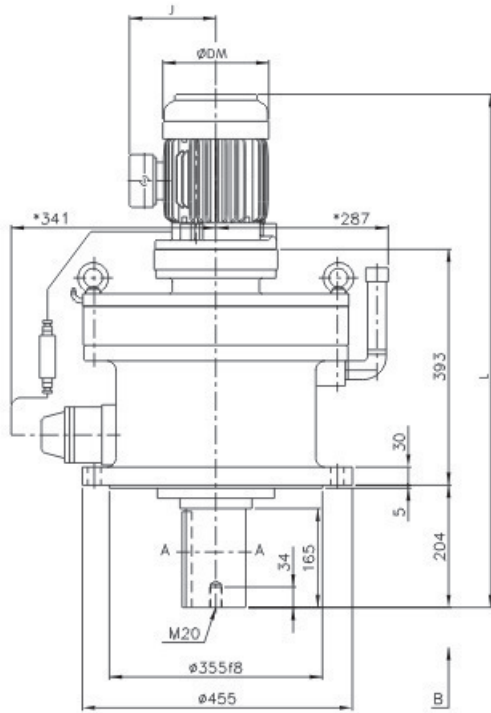

Motor			TRANSCYKO Model No.	Metric ( mm, kg )					Inches ( in.lbs )				
KW	HP	POLE		L	J	DM	H	Weight	L	J	DM	H	Weight
0.2	1/2	4	TDVM05-620/11	836	132	162		254	32.91	5.20	6.38		558.8
0.75	1	4	TDVM1-620/11	845	137	177		262	33.27	5.39	6.97		576.4
1.5	2	4	TDVM2-620/11	882	150	200		269	34.72	6.14	7.87		591.8
2.2	3	4	TDVM3-620/11	908	173	219		275	35.75	6.81	8.62		605.0
3.7	5	4	TDVM5-620/11	924	188	238		281	36.38	7.40	9.37		618.2



# TDVM-620/13

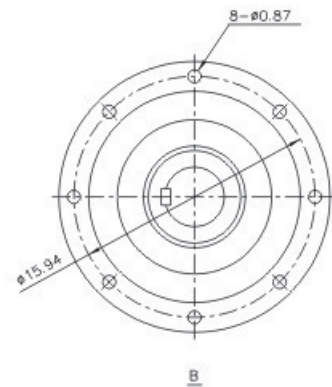
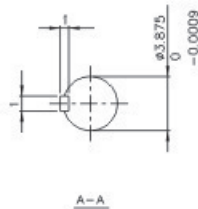
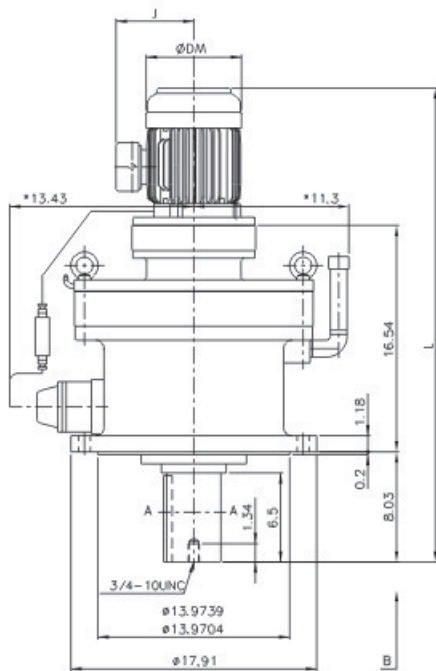
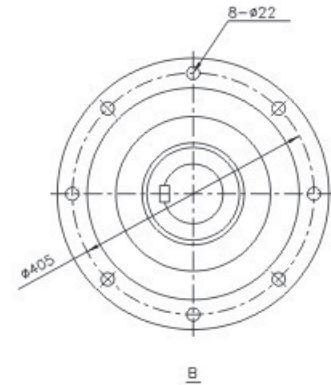
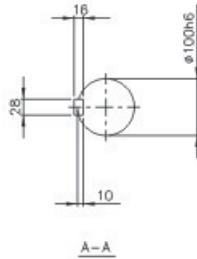
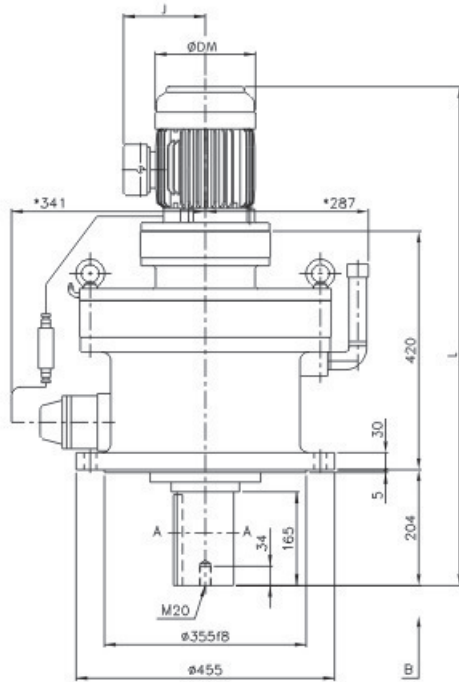

Motor			TRANSCYKO Model No.	Metric ( mm, kg )					Inches ( in.lbs )				
KW	HP	POLE		L	J	DM	H	Weight	L	J	DM	H	Weight
0.75	1	4	TDVM1-618/13	868	143	177		273	34.17	5.63	6.97		600.6
1.5	2	4	TDVM2-628/13	908	150	200		284	35.75	5.91	7.87		624.8
2.2	3	4	TDVM3-628/13	935	173	219		294	36.81	6.81	8.62		646.8
3.7	5	4	TDVM5-628/13	954	187	238		303	37.56	7.36	9.37		666.6
5.5	7.5	4	TDVM8-628/13	998	218	273		311	39.29	8.58	10.75		684.2
7.5	10	4	TDVM10-628/13	1036	223	273		313	40.79	8.78	10.75		688.6

**TDVM-621/13**

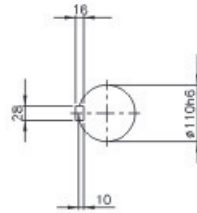
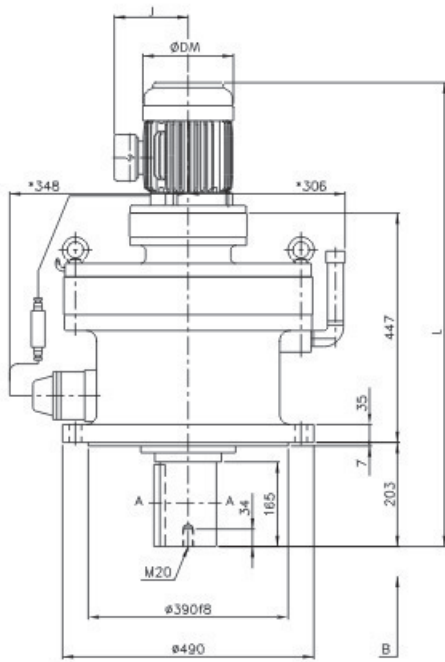

A-A

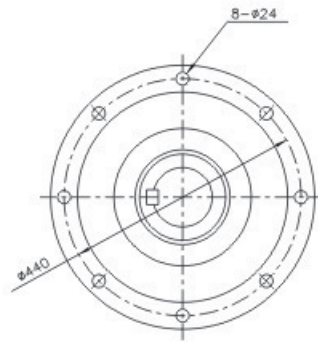

B

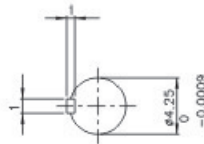
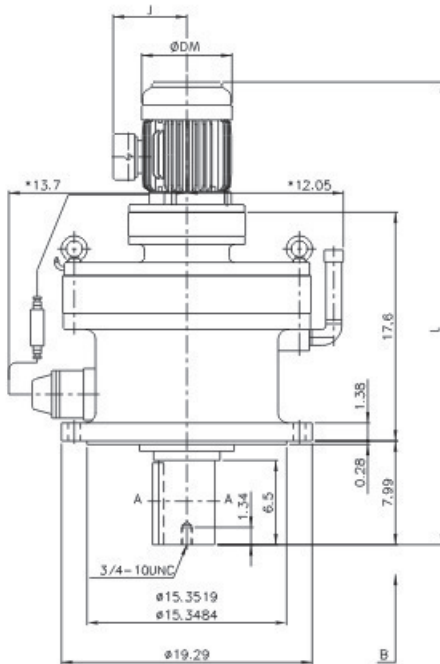

A-A

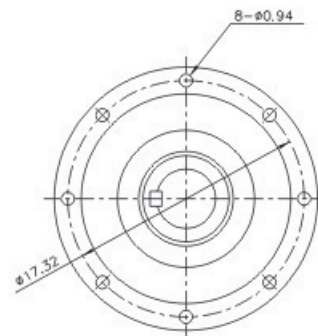

B

Motor			TRANSCYKO Model No.	Metric ( mm, kg )					Inches ( in.lbs )				
KW	HP	POLE		L	J	DM	H	Weight	L	J	DM	H	Weight
0.75	1	4	TDVM1-621/13	894	143	177		329	35.20	5.63	6.97		723.8
1.5	2	4	TDVM2-621/13	934	150	200		342	36.77	5.91	7.87		752.4
2.2	3	4	TDVM3-621/13	961	173	219		354	37.83	6.81	8.62		778.8
3.7	5	4	TDVM5-621/13	980	187	238		361	38.58	7.36	9.37		794.2
5.5	7.5	4	TDVM8-621/13	1024	218	273		365	40.31	8.58	10.75		803.0
7.5	10	4	TDVM10-621/13	1062	223	273		373	41.81	8.78	10.75		820.6

**TDVM-621/16**

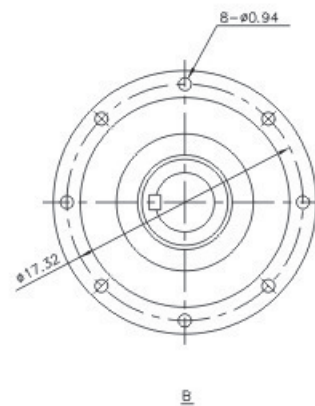
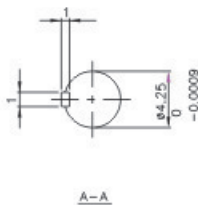
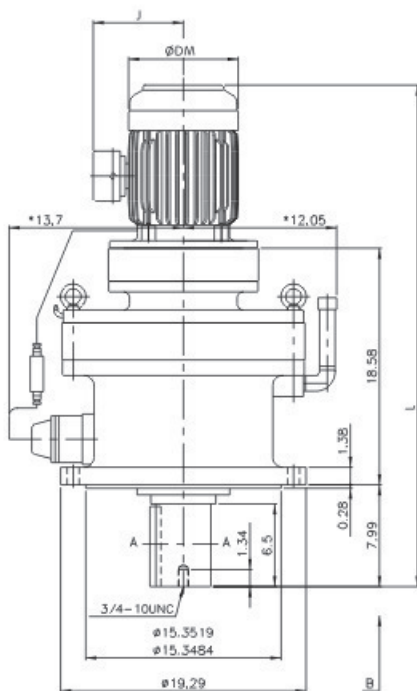
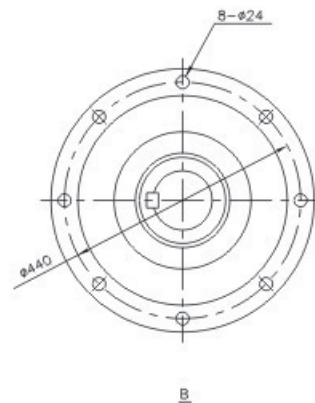
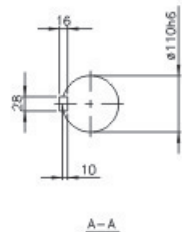
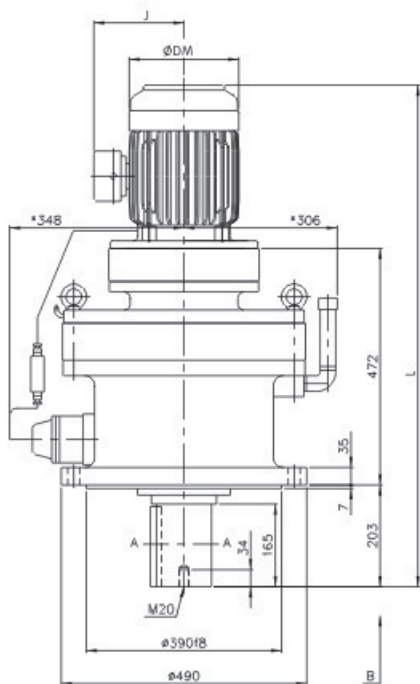

Motor			TRANSCYKO Model No.	Metric ( mm, kg )					Inches ( in.lbs )				
KW	HP	POLE		L	J	DM	H	Weight	L	J	DM	H	Weight
2.2	3	4	TDVM3-621/16	989	173	219		385	38.94	6.81	8.62		803.0
3.7	5	4	TDVM5-621/16	1008	182	238		375	39.69	7.17	9.37		825.0
5.5	7.5	4	TDVM8-621/16	1042	219	273		384	41.02	8.62	10.75		844.8
7.5	10	4	TDVM10-621/16	1080	219	273		387	42.52	8.62	10.75		851.4
11	15	4	TDVM15-621/16	1167	256	334		412	45.94	10.08	13.15		906.4



**TDVM-622/13**

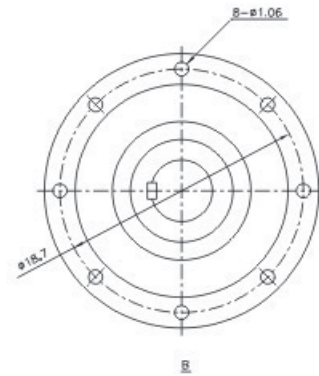
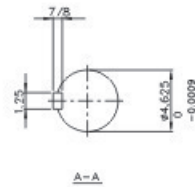
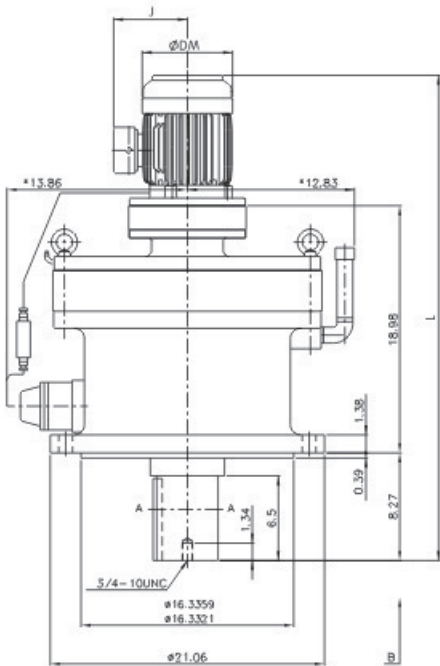
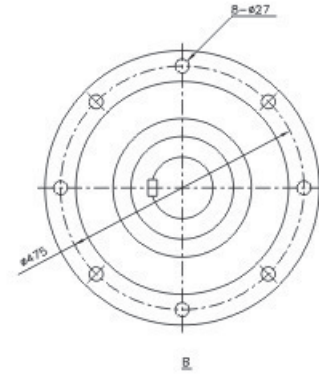
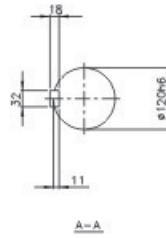
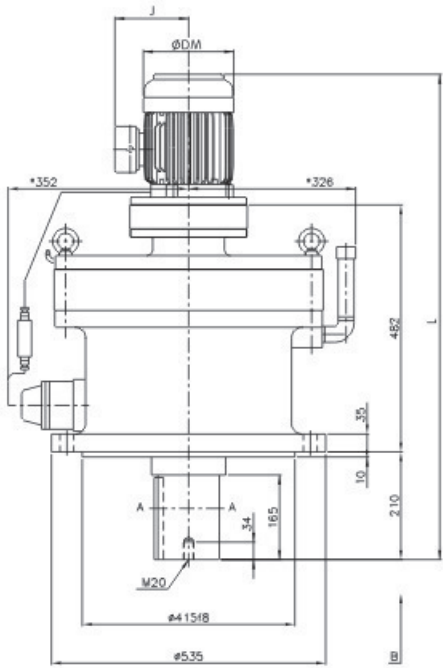

Motor			TRANSCYKO Model No.	Metric ( mm, kg )					Inches ( in.lbs )				
KW	HP	POLE		L	J	DM	H	Weight	L	J	DM	H	Weight
0.75	1	4	TDVM1-622/13	936	143	177		419	36.85	5.63	6.97		921.8
1.5	2	4	TDVM2-622/13	976	150	200		432	38.45	5.91	7.87		950.4
2.2	3	4	TDVM3-622/13	1003	173	219		444	39.49	6.81	8.62		976.8
3.7	5	4	TDVM5-622/13	1022	187	238		449	40.24	7.36	9.37		987.8
5.5	7.5	4	TDVM8-622/13	1066	218	273		453	41.97	8.58	10.75		996.6
7.5	10	4	TDVM10-622/13	1104	223	273		461	43.46	8.78	10.75		1014

TDVM-622/17

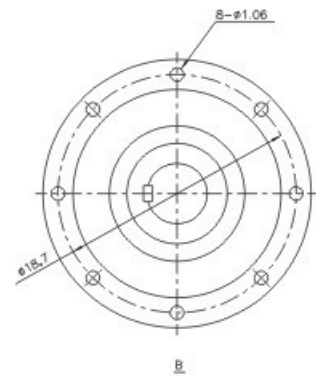
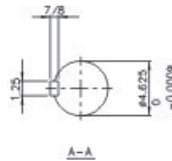
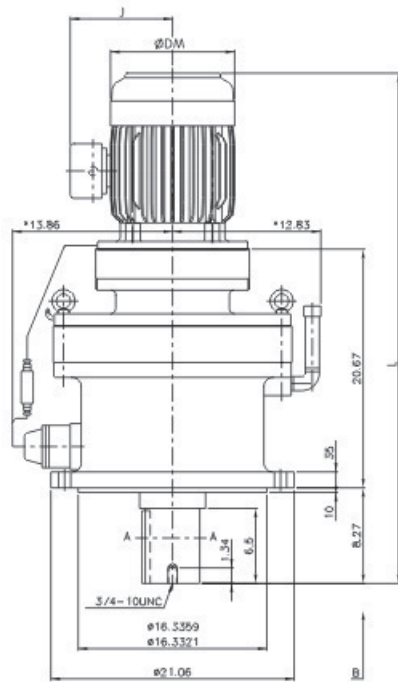
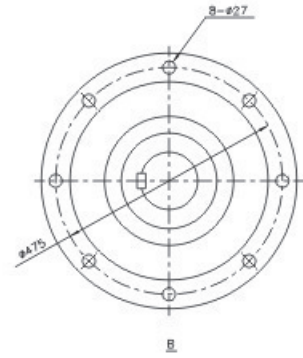
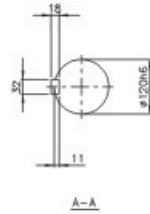
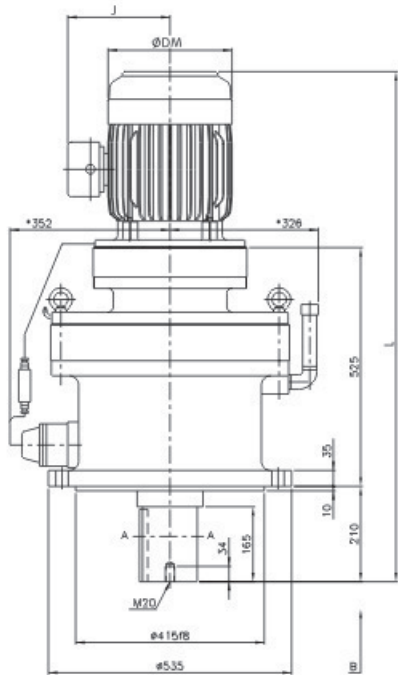

Motor			TRANSCYKO Model No.	Metric ( mm, kg )					Inches ( in.lbs )				
KW	HP	POLE		L	J	DM	H	Weight	L	J	DM	H	Weight
3.7	5	4	TDVM5-622/17	1080	182	219		437	42.52	7.17	8.37		961.0
5.5	7.5	4	TDVM8-622/17	1114	218	238		450	43.86	8.58	10.75		990.0
7.5	10	4	TDVM10-622/17	1152	218	273		462	45.35	8.58	10.75		1016
11	15	4	TDVM15-622/17	1227	256	273		513	48.31	10.08	13.15		1129
15	20	4	TDVM20-622/17	1271	256	334		567	50.04	10.08	13.15		1147

**TDVM-623/16**

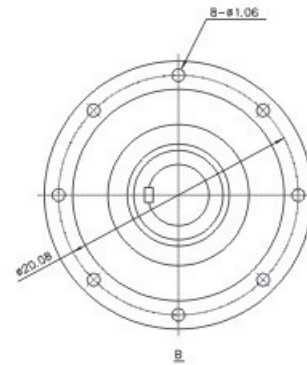
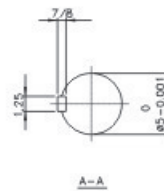
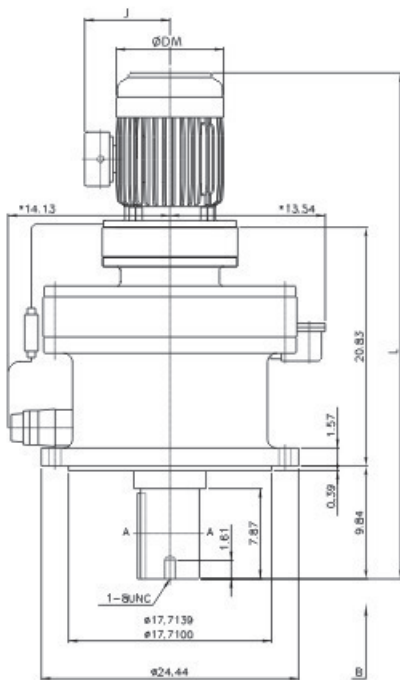
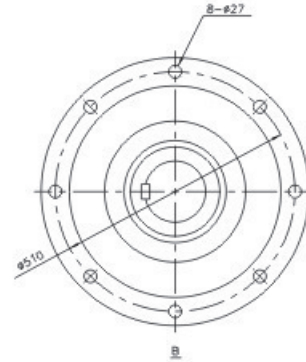
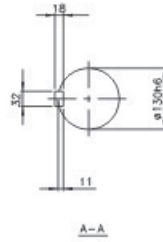
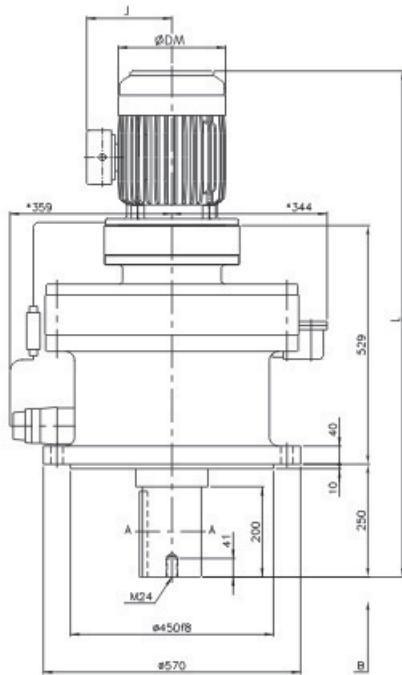

Motor			TRANSCYKO Model No.	Metric ( mm, kg )					Inches ( in.lbs )				
KW	HP	POLE		L	J	DM	H	Weight	L	J	DM	H	Weight
2.2	3	4	TDVM3-623/16	1092	173	219		526	42.99	6.81	8.62		1157
3.7	5	4	TDVM5-621/16	1111	182	238		548	43.74	7.17	9.37		1206
5.5	7.5	4	TDVM8-623/16	1145	219	273		556	45.08	8.62	10.75		1223
7.5	10	4	TDVM10-623/16	1183	219	273		569	46.57	8.62	10.75		1252
11	15	4	TDVM15-623/16	1270	256	334		603	50.00	10.08	13.15		1327
15	20	4	TDVM20-623/16	1314	256	334		622	51.73	10.08	13.15		1368



# TDVM-623/18

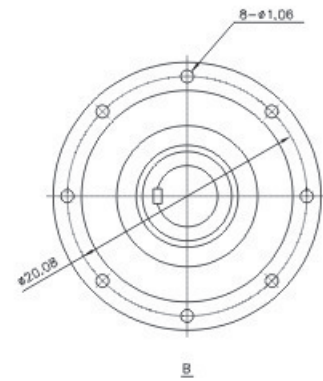
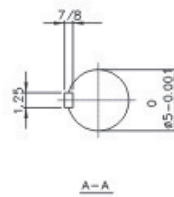
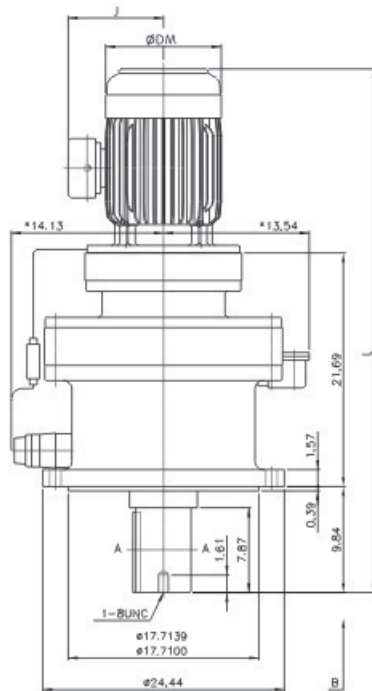
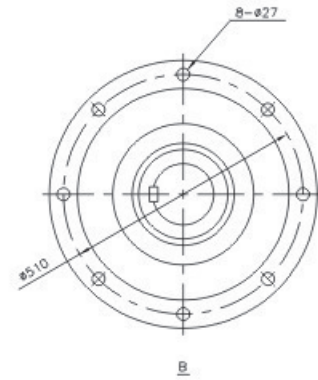
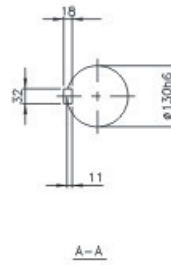
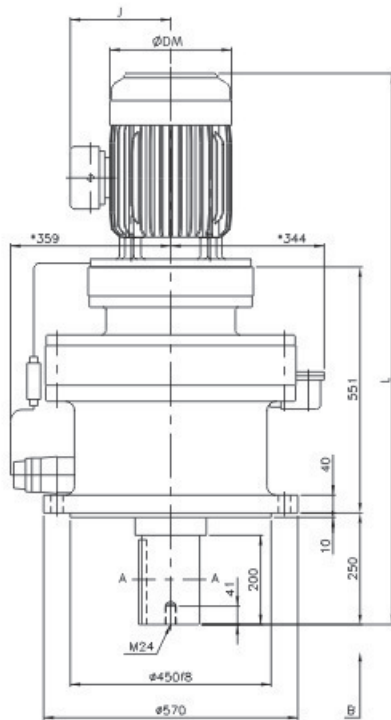

Motor			TRANSCYKO Model No.	Metric ( mm, kg )					Inches ( in.lbs )				
KW	HP	POLE		L	J	DM	H	Weight	L	J	DM	H	Weight
7.5	10	4	TDVM10-623/18	1226	224	273		572	48.27	8.82	10.75		1258
11	15	4	TDVM5-623/18	1294	256	334		656	50.94	10.08	13.15		1443
15	20	4	TDVM20-623/18	1338	256	334		661	52.68	10.08	13.15		1454
18.5	25	4	TDVM25-623/18	1361	305	382		723	53.58	12.01	15.04		1591
22	30	4	TDVM30-623/18	1361	305	382		723	53.58	12.01	15.04		1591

**TDVM-624/16**

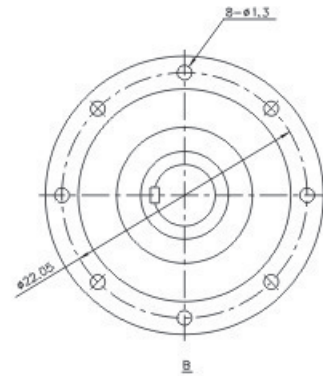
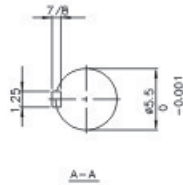
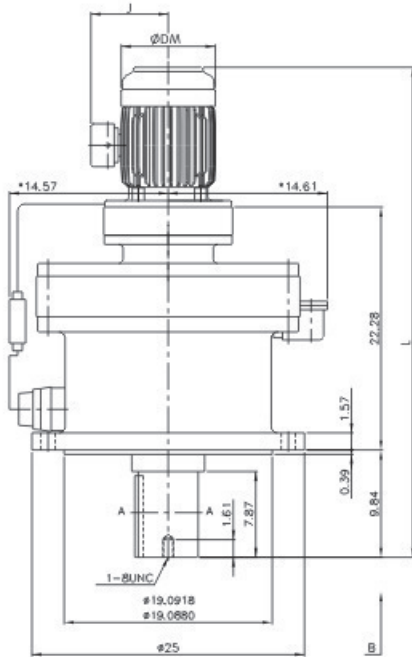
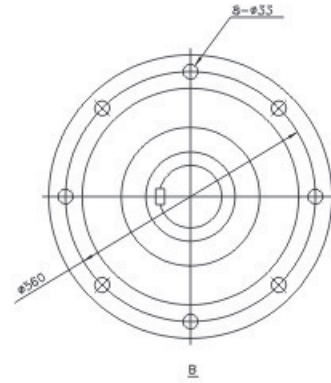
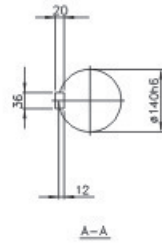
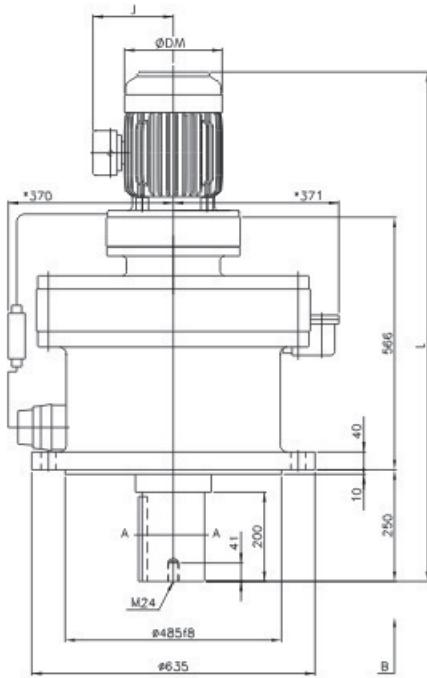

Motor			TRANSCYKO Model No.	Metric ( mm, kg )					Inches ( in.lbs )				
KW	HP	POLE		L	J	DM	H	Weight	L	J	DM	H	Weight
2.2	3	4	TDVM3-624/16	1130	173	219		622	44.49	6.81	<b>8.62</b>		1368
3.7	5	4	TDVM5-624/16	1149	182	239		634	45.24	7.17	9.37		1395
5.5	7.5	4	TDVM8-624/16	1183	219	273		650	46.57	8.62	10.75		1430
7.5	10	4	TDVM10-624/16	1221	219	273		665	48.07	8.62	10.75		1463
11	15	4	TDVM15-624/16	1308	256	334		697	51.50	10.08	13.15		1533
15	20	4	TDVM20-624/16	1352	256	334		716	53.23	10.08	13.15		1575





**TDVM-625/17**

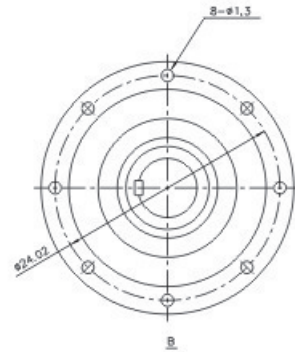
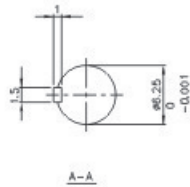
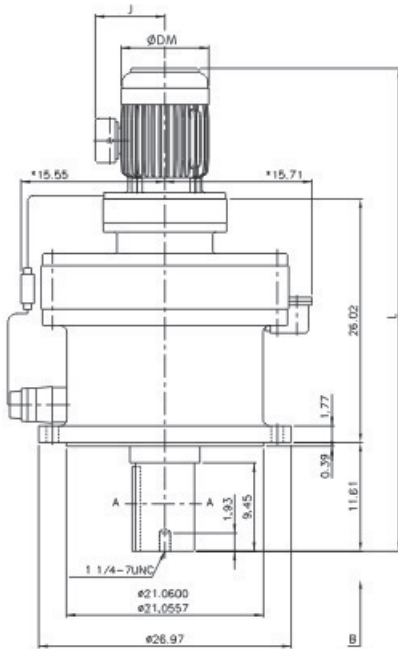
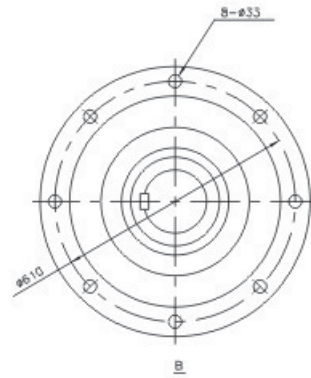
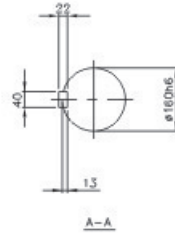
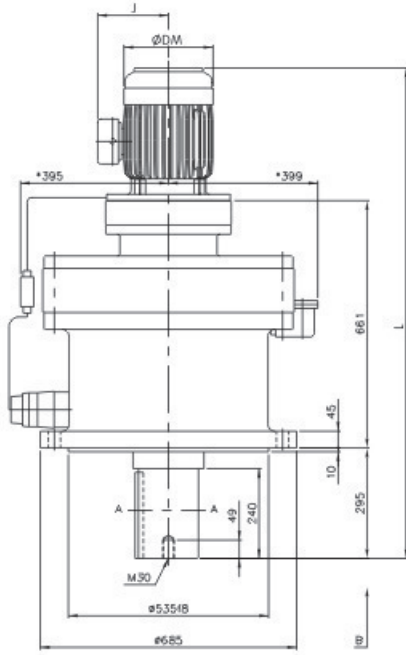

Motor			TRANSCYKO Model No.	Metric ( mm, kg )					Inches ( in.lbs )				
KW	HP	POLE		L	J	DM	H	Weight	L	J	DM	H	Weight
3.7	5	4	TDVM5-625/17	1301	182	238		968	51.22	7.17	9.37		2130
5.5	7.5	4	TDVM8-625/17	1335	218	273		984	52.56	8.58	10.75		2165
7.5	10	4	TDVM10-625/17	1373	218	273		993	54.06	8.58	10.75		2185
11	15	4	TDVM15-625/17	1448	256	334		1035	57.01	10.08	13.15		2277
15	20	4	TDVM20-625/17	1492	256	334		1041	58.74	10.08	13.15		2290
18.5	25	4	TDVM25-625/17	1517	305	382		1105	59.72	12.01	15.04		2431
22	30	4	TDVM30-625/17	1517	305	382		1105	59.72	12.01	15.04		2431

**TDVM-625/19**

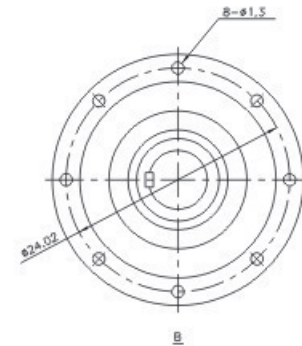
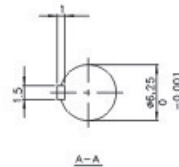
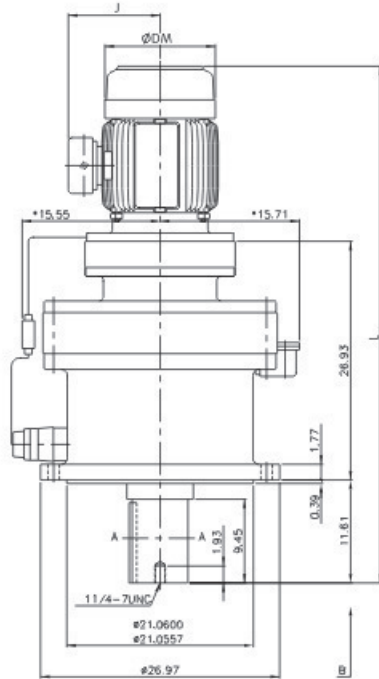
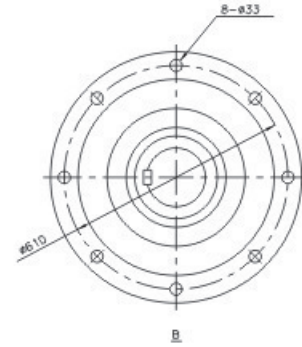
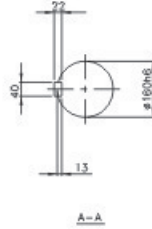
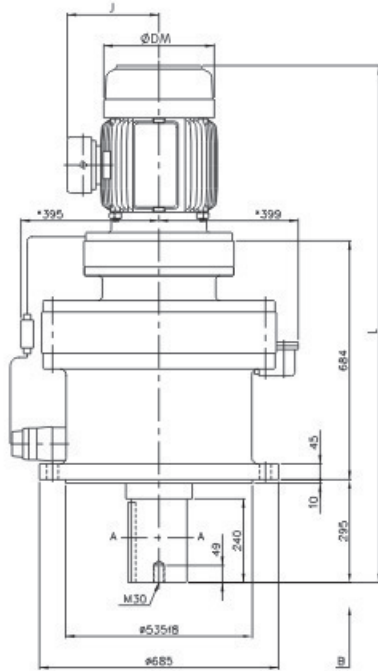

Motor			TRANSCYKO Model No.	Metric ( mm, kg )					Inches ( in.lbs )				
KW	HP	POLE		L	J	DM	H	Weight	L	J	DM	H	Weight
7.5	10	4	TDVM10-625/19	1401	224	273		1001	55.16	8.82	10.75		2202
11	15	4	TDVM15-625/19	1476	261	334		1057	58.11	10.28	13.15		2325
15	20	4	TDVM20-625/19	1520	261	334		1108	59.84	10.28	13.15		2438
18.5	25	4	TDVM25-625/19	1539	305	382		1181	60.59	12.01	15.04		2598
22	30	4	TDVM30-625/19	1539	305	382		1181	60.59	12.01	15.04		2598
30	40	4	TDVM40-625/19	1577	305	382		1195	62.09	12.01	15.04		2629

**TDVM-626/19**

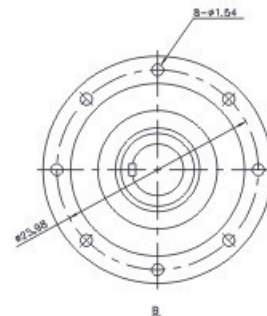
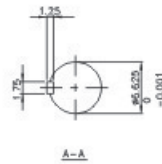
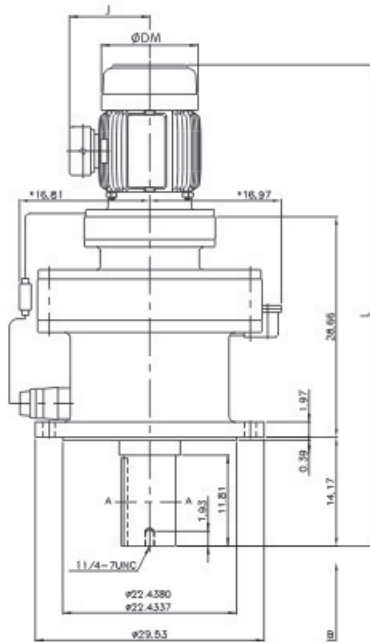
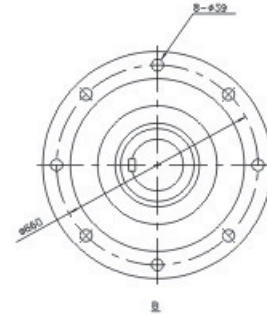
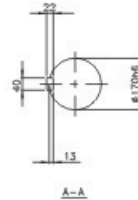
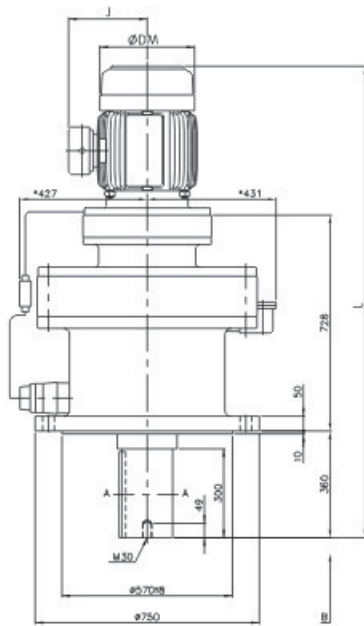

Motor			TRANSCYKO Model No.	Metric ( mm, kg )					Inches ( in.lbs )				
KW	HP	POLE		L	J	DM	H	Weight	L	J	DM	H	Weight
5.5	7.5	4	TDVM8-626/19	1473	224	273		1181	57.99	8.82	10.75		2598
7.5	10	4	TDVM10-626/19	1511	224	273		1193	59.49	8.82	10.75		2625
11	15	4	TDVM15-626/19	1586	261	334		1324	62.44	10.28	13.15		2913
15	20	4	TDVM20-626/19	1630	261	334		1374	64.17	10.08	13.15		3023
18.5	25	4	TDVM25-626/19	1649	305	382		1451	64.92	12.01	15.04		3192
22	30	4	TDVM30-626/19	1649	305	382		1451	64.92	12.01	15.04		3192
30	40	4	TDVM40-626/19	1687	305	382		1465	66.42	12.01	15.04		3223
37	50	4	TDVM50-626/19	1750	339	420		1499	68.90	13.35	16.54		3298



**TDVM-627/19**

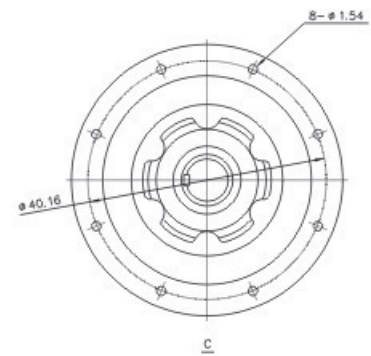
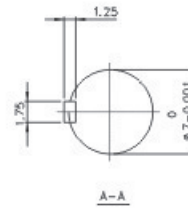
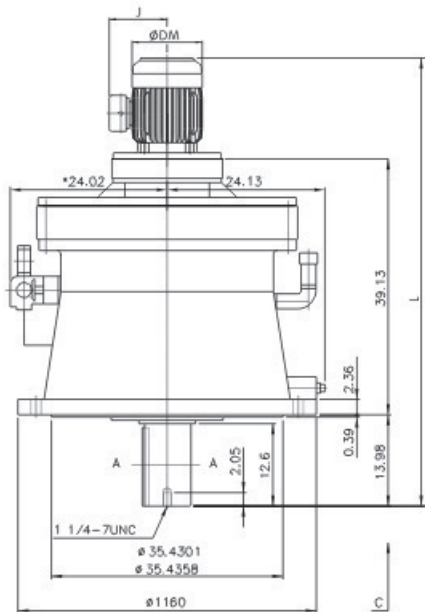
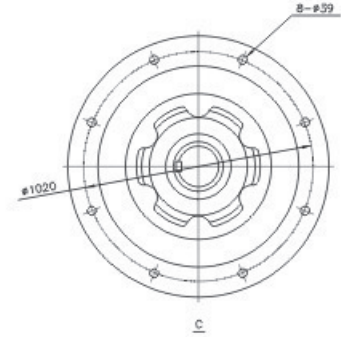
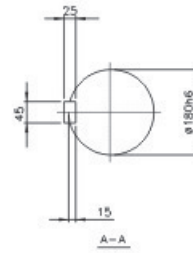
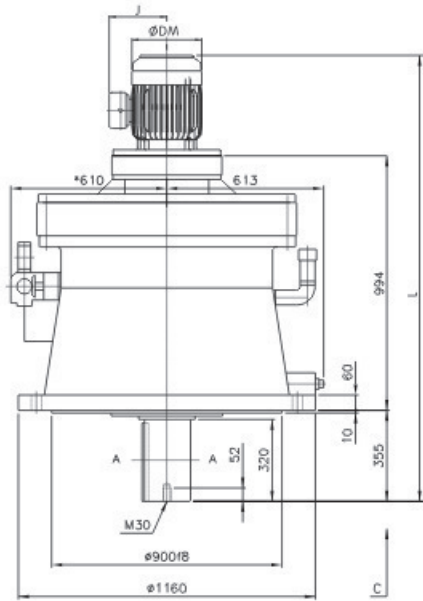

Motor			TRANSCYKO Model No.	Metric ( mm, kg )					Inches ( in.lbs )				
KW	HP	POLE		L	J	DM	H	Weight	L	J	DM	H	Weight
5.5	7.5	4	TDVM8-627/19	1734	224	273		2681	68.27	8.82	10.75		2598
7.5	10	4	TDVM10-627/19	1772	224	273		2713	69.76	8.82	10.75		5969
11	15	4	TDVM15-627/19	1847	261	334		2740	72.72	10.28	13.15		6028
15	20	4	TDVM20-627/19	1891	261	334		2759	74.45	10.08	13.15		6070
18.5	25	4	TDVM25-627/19	1910	305	382		2834	75.20	12.01	15.04		6235
22	30	4	TDVM30-627/19	1910	305	382		2834	75.20	12.01	15.04		6235
30	40	4	TDVM40-627/19	1948	305	382		2850	76.69	12.01	15.04		6270
37	50	4	TDVM50-627/19	2011	339	420		2883	79.17	13.35	16.54		6343

# SELECTION AND DIMENSIONS OF TRANSCYKO SPEED REDUCERS

- How To Select A Suitable TRANSCYKO Speed Reducer
- Selection Tables
- Dimension Pages

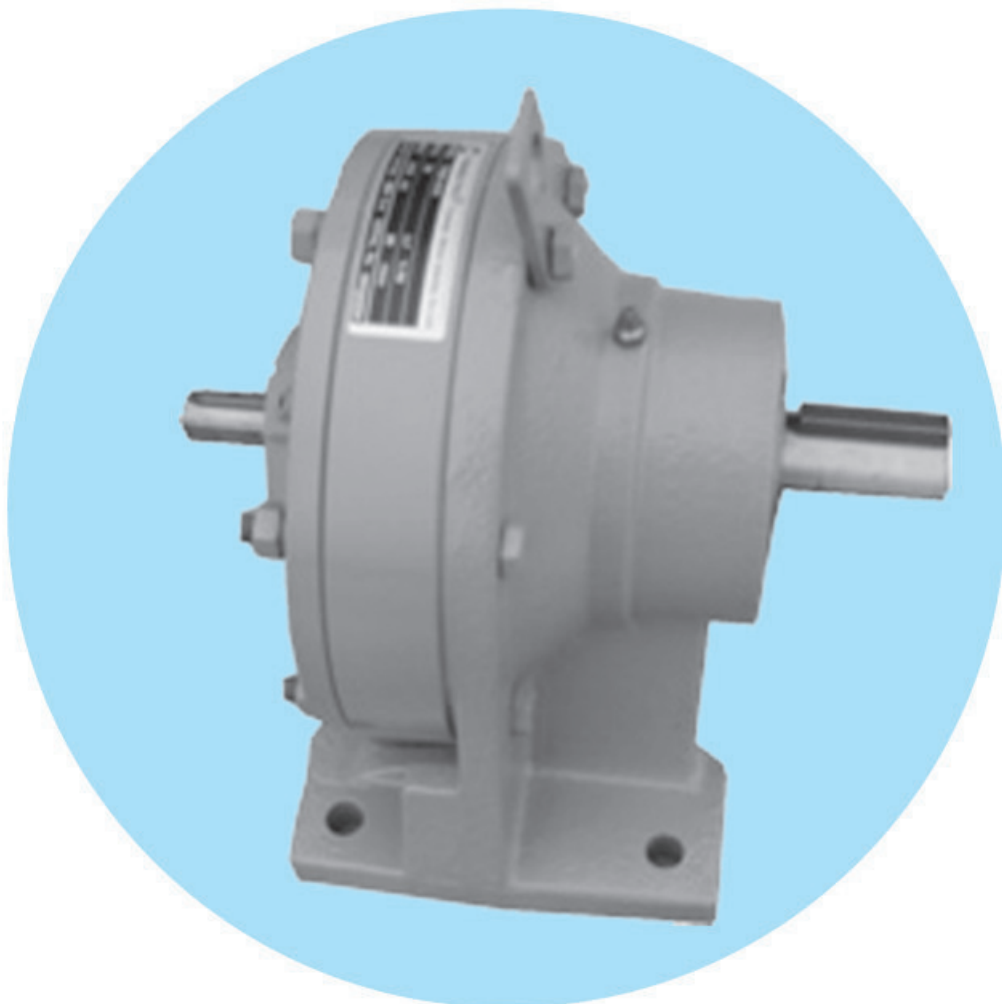

# HOW TO SELECT A SUITABLE TRANSCYKO SPEED REDUCER

## Example 1

- Given Conditions: 1. Driven machine application: Mixer, shaft coupling, output shaft vertical down, V-flange mounting  
 2. Operation time: 10 hours/day  
 3. Input speed: 1,200 R.P.M. Output R.P.M. of reducer: 28 R.P.M.  
 4. Transmitted torque on slow speed shaft (output) of reducer = 450 kg·m (39,060 in·lbs)
- Step 1: Refer to "Machine Load Classifications" determine the machine load Characteristic=M. Review the "Recommended TRANSCYKO Load Factors", table, determine the load factor=1.2
- Step 2: Required ratio=Input R.P.M. of reducer/Output R.P.M. of reducer=1200/28≈43
- Step 3: Transmitted torque on output shaft of reducer X load factor=450 kg·m (39,060 in·lbs) x 1.2=540 kg·m (46,872 in·lbs)
- Step 4: Since "Transmitted torque on output shaft of reducer x load factor ≤ Allowable output Torque of reducer", from the Selection Table of ratio 43 on page 166, on the column of 1200 input R.P.M., the frame size to suite the above requirement is 619.
- Step 5: The complete model designation would be TDV-619-43.

## Example 2

- Given Conditions: 1. Driven machine application: Chain Conveyor (Variable feed), Horizontal foot mounted, sprocket pitch circle radius R=0.15m, Radial load position: center of slow speed shaft, light shock.  
 2. Operation time: 24 hours/day  
 3. Input speed: 600 R.P.M., Output speed: 20 R.P.M.  
 4. Transmitted torque on slow speed shaft (Output) of reducer: 400 kg·m (34,720 in·lbs)
- Step 1: Refer to "Machine Load Classifications", determine the machine load Characteristic=M. Review the "Recommended TRANSCYKO Load Factors" table, determine the load factor=1.35
- Step 2: Reduction ratio=Input R.P.M. of reducer/Output R.P.M. of reducer=600/20≈29
- Step 3: Transmitted torque on output shaft of reducer x load factor=400 kg·m (34,720 in·lbs) x 1.35=540 kg·m (46,872 in·lbs)
- Step 4: Since "Transmitted torque on output shaft of reducer x load factor ≤ Allowable output Torque of reducer", from the Selection Table of ratio 29 on page 165, on the column of 600 input R.P.M., the frame size to suite the above requirement is 619.
- Step 5: Check the overhung load on slow speed shaft

$$\text{Actual Overhung Load} = \frac{T_l}{R} \leq \frac{\text{Allowable Overhung Load}}{L_f \times C_f \times F_s}$$

$$\text{Actual Overhung Load} = \frac{400}{0.15} \leq 2667 \leq \frac{5020}{1 \times 1 \times 1.2} = 4183$$

Frame size 619 is O.K.

- Step 6: The complete model designation would be THH-619-29.



# SELECTION TABLE FOR SINGLE STAGE REDUCERS

(Allowable Transmission Input-Output Capacity)

**Ratio**      **6**

Input Speed(R.P.M)	1800		1500		1200		1000		900		750		600		50 and Below	Dimension page	
Output Speed(R.P.M)	106		88		71		59		53		44		35		8.3 and Below		
Frame Size	Input KW HP	Output Torque kgf.m/min.lbs	Input KW HP	Output Torque kgf.m/min.lbs	Input KW HP	Output Torque kgf.m/min.lbs	Input KW HP	Output Torque kgf.m/min.lbs	Input KW HP	Output Torque kgf.m/min.lbs	Input KW HP	Output Torque kgf.m/min.lbs	Input KW HP	Output Torque kgf.m/min.lbs	Output Torque kgf.m/min.lbs	H	V
608	0.42 0.56	1.25 108	0.40 0.54	1.43 124	0.36 0.48	1.61 140	0.33 0.44	1.79 156	0.31 0.42	1.85 161	0.27 0.36	1.95 169	0.22 0.30	2.00 178	2 178	180	209
609	1.34 1.80	4.05 352	1.33 1.78	4.80 417	1.13 1.52	3.10 443	1.00 1.34	5.40 459	0.94 1.26	5.65 491	0.83 1.11	5.98 520	0.71 0.95	6.40 556	7 608	181	210
610	2.26 3.03	6.81 592	2.21 2.96	8.0 695	1.86 2.49	8.4 730	1.73 2.32	9.4 816	1.69 2.27	10.2 886	1.52 2.04	11.1 964	1.33 1.78	12.0 1043	15 1304	181	210
611	4.88 6.54	14.7 1277	4.96 6.65	17.9 1556	4.25 5.70	19.2 1668	3.78 5.07	20.5 1781	3.50 4.69	21.1 1834	3.09 4.14	22.3 1938	2.69 3.61	24.3 2112	30 2607	182	211
612	6.78 9.09	20.1 1747	6.62 8.88	23.9 2077	5.84 7.84	26.4 2294	5.13 6.88	27.8 2416	4.73 6.34	28.5 2477	4.04 5.42	29.2 2537	3.30 4.92	29.8 2590	30 2607	182	211
613	9.97 13.4	30.0 2607	9.97 13.4	36.0 3128	8.64 11.6	39.0 3389	7.59 10.2	41.1 3572	6.98 9.36	42.0 3650	6.19 8.30	44.7 3884	5.32 7.13	48.0 4171	61 5301	183	212
615	13.0 17.4	57.4 4982.32	13.0 17.4	70 6076	11.2 15.0	87.1 7560.28	9.97 13.4	100 8680	9.22 12.4	108.4 9409.12	8.25 11.1	112 9721.6	6.73 9.02	112 9721.6	112 9721.6	184	213
616	14.6 19.6	63.1 5477.08	14.6 19.6	76.2 6614.16	12.5 16.8	94.7 8219.96	11.0 14.8	113 9808.4	10.2 13.7	126 10936.8	9.00 12.1	131 11370.8	7.70 10.3	131 11370.8	131 11370.8	184	213
617	22.5 30.2	67.6 5868	21.4 28.9	77.2 6701	18.4 24.7	82.6 7170	16.1 21.6	87.2 7569	15.0 20.1	90.0 7812	13.2 17.7	95.1 8255	11.3 15.2	102 8854	110 9548	185	214

**Ratio**      **8**

Input Speed(R.P.M)	1800		1500		1200		1000		900		750		600		50 and Below	Dimension page	
Output Speed(R.P.M)	106		88		71		59		53		44		35		6.3 and Below		
Frame Size	Input KW HP	Output Torque kgf.m/min.lbs	Input KW HP	Output Torque kgf.m/min.lbs	Input KW HP	Output Torque kgf.m/min.lbs	Input KW HP	Output Torque kgf.m/min.lbs	Input KW HP	Output Torque kgf.m/min.lbs	Input KW HP	Output Torque kgf.m/min.lbs	Input KW HP	Output Torque kgf.m/min.lbs	Output Torque kgf.m/min.lbs	H	V
608	0.42 0.54	1.62 141	0.42 0.54	1.93 168	0.39 0.52	2.34 203	0.37 0.50	2.69 233	0.34 1.80	2.77 240	0.30 0.40	2.92 253	0.26 0.35	3.15 273	4 348	180	209
609	1.34 1.80	5.40 469	1.35 1.81	6.49 563	1.16 1.56	6.98 606	1.02 1.37	7.38 640	0.95 1.27	7.60 660	0.83 1.11	8.04 698	0.72 0.96	8.63 749	11 956	181	210
610	3.76 3.70	11.1 963	2.72 3.65	13.1 1137	2.32 3.11	14.0 1215	2.08 2.79	15.0 1302	1.91 2.56	15.3 1328	1.71 2.29	16.5 1432	1.45 1.94	17.5 1519	21 1823	181	210
611	5.01 6.72	20.1 1745	5.02 6.73	24.2 2100	4.30 5.77	25.9 2248	3.76 5.04	27.2 2361	3.52 4.72	28.3 2456	3.10 4.16	29.9 2595	2.64 3.54	31.8 2760	41 3559	182	211
612	6.78 9.09	27.2 2361	6.83 9.16	32.9 2856	5.83 7.82	35.1 3047	5.12 6.87	27.0 3212	4.81 6.45	38.6 3350	4.22 5.66	40.6 3524	3.39 4.54	40.8 3541	41 3559	182	211
613	10.0 13.4	40.2 3489	10.0 13.4	48.2 4182	8.65 11.6	52.1 4522	7.66 10.3	55.3 4800	7.01 9.40	56.3 4887	6.35 8.52	61.2 5312	5.40 7.24	65.0 5642	77 6684	183	212
615	12.9 17.3	68 5902.4	13.0 17.4	91 7898.8	10.9 14.6	113 9808.4	9.79 13.1	128 11110.4	9.08 12.2	140 12152	8.00 10.7	148 12846.4	6.81 9.13	148 12846.4	148 12846.4	184	213
616	17.9 24.0	81 6232	17.8 23.9	99 7439	16.9 22.7	122.5 8854	15.1 20.2	146 9461	18.6 18.6	164 9722	12.4 16.6	175 10416	10.5 14.1	175 11024	175 13280	184	213

**Ratio**      **11**

Input Speed(R.P.M)	1800		1500		1200		1000		900		750		600		50 and Below	Dimension page	
Output Speed(R.P.M)	106		88		71		59		53		44		35		4.5 and Below		
Frame Size	Input KW HP	Output Torque kgf.m/min.lbs	Input KW HP	Output Torque kgf.m/min.lbs	Input KW HP	Output Torque kgf.m/min.lbs	Input KW HP	Output Torque kgf.m/min.lbs	Input KW HP	Output Torque kgf.m/min.lbs	Input KW HP	Output Torque kgf.m/min.lbs	Input KW HP	Output Torque kgf.m/min.lbs	Output Torque kgf.m/min.lbs	H	V
607	0.24 0.32	1.32 115	0.24 0.32	1.61 140	0.21 0.28	1.72 149	0.18 0.24	1.80 156	0.17 0.23	1.88 163	0.15 0.20	1.98 172	0.13 0.17	2.10 182	2.5 217	180	209
608	0.40 0.54	2.20 191	0.40 0.54	2.64 229	0.40 0.54	3.27 284	0.37 0.50	3.72 323	0.34 0.46	3.80 330	0.30 0.40	4.00 347	0.25 0.34	4.16 361	5.1 443	180	209
609	1.21 1.62	6.70 582	1.22 1.64	8.10 703	1.04 1.39	8.65 751	0.92 1.23	9.14 793	0.83 1.15	9.46 821	0.75 1.00	9.97 865	0.64 0.86	10.6 920	11 955	181	210
610	2.70 3.62	14.9 1293	2.72 3.65	18.0 1562	2.32 3.11	19.2 1666	2.05 2.75	20.4 1771	1.88 2.52	20.8 1805	1.57 2.10	20.8 1805	1.26 1.69	20.9 1814	21 1823	181	210
611	4.98 6.68	27.5 1287	5.03 6.74	33.3 28.9	4.26 5.70	35.3 3064	3.76 5.04	37.4 3246	3.57 4.79	39.4 3420	3.13 4.20	41.5 3602	2.69 3.61	44.6 3871	51 4427	182	211
612	4.96 6.65	27.4 2378	5.07 6.80	33.6 2916	4.34 5.82	35.9 3116	3.78 5.07	37.6 3264	3.59 4.81	39.6 3437	3.16 4.24	41.9 3637	2.72 3.65	45.0 3906	51 4427	182	211
613	9.77 13.1	53.9 4678	9.69 13.0	64.2 5572	8.40 11.3	69.5 6033	7.37 9.88	73.2 6354	6.82 9.14	75.3 6536	5.78 7.75	76.6 6649	4.64 6.22	76.8 6666	77 6684	183	212
614	9.93 13.3	54.8 4757	9.84 13.2	65.2 5659	8.50 11.4	70.4 6110	7.50 10.0	74.5 6467	7.02 9.41	77.5 6727	6.15 8.25	81.4 7066	6.31 7.12	87.9 7630	103 8940	183	212
615	12.9 17.3	104 9027.2	13.0 17.4	125 10850	11.1 14.9	148 12846.4	9.70 13.0	168 14582.4	8.90 11.9	168 14582.4	7.70 10.3	168 14582.4	6.16 8.26	168 14582.4	168 14582.4	184	213
616	17.8 23.5	112 9721.6	18.1 24.3	136 11804.8	17.2 23.1	169 14669.2	14.9 20.0	175 15190	13.5 18.1	175 15190	11.2 15.0	175 15190	9.06 12.1	175 15190	175 13020	184	213
617	26.8 35.9	148 12846	27.0 36.2	179 15537	22.6 30.3	187 16232	19.5 26.2	194 16839	18.5 24.8	204 17707	16.2 21.7	214 18575	13.9 18.6	230 19964	255 22134	185	214
618	32.4 43.4	179 15537	32.3 43.3	214 18575	24.2 44.2	273 23696	29.2 39.2	290 25172	27.4 36.7	302 26214	23.7 31.8	314 27255	20.2 27.1	335 29078	335 29078	185	214
619	43.3 58.1	239 20745	43.3 58.1	287 245912	39.7 53.2	329 29557	35.2 47.2	350 30380	32.6 43.7	360 31248	28.8 38.6	382 33158	24.8 33.2	410 35588	570 49476	186	215
620	57.8 77.5	319 27689	57.7 77.4	282 33158	52.4 70.3	434 37671	46.9 62.9	466 40449	44.1 59.1	487 42272	38.6 51.8	512 44442	32.3 43.3	535 46438	570 49476	186	215



Input Speed(R.P.M)	1800		1500		1200		1000		900		750		600		50 and Below	Dimension page	
Output Speed(R.P.M)	164		136		109		91		82		68		55		4.5 and Below		
Frame Size	Input KW HP	Output Torque kgf.m/min.lbs	Input KW HP	Output Torque kgf.m/min.lbs	Input KW HP	Output Torque kgf.m/min.lbs	Input KW HP	Output Torque kgf.m/min.lbs	Input KW HP	Output Torque kgf.m/min.lbs	Input KW HP	Output Torque kgf.m/min.lbs	Input KW HP	Output Torque kgf.m/min.lbs	Output Torque kgf.m/min.lbs	H	V
621	69.6 93.3	384 33331	69.8 93.6	462 40102	67.6 90.5	550 48608	61.5 82.5	611 53035	57.9 77.6	639 55465	52.1 69.9	650 59892	43.4 58.2	718 62322	730 63364	187	216
622	96.0 129	530 46004	96.5 129	639 55465	85.6 1209	742 64406	80.5 108	800 69440	75.6 101	835 72478	68.0 91.2	901 78207	58.2 78.0	964 83675	970 84196	187	216
623					2.3 124	764 66315	92.7 124	921 79943	92.4 124	1020 88536	80.2 108	1062 92162	68.8 92.3	1139 98865	1140 98952	188	217
624					117 157	969 84109	117 157	1159 100601	117 157	1295 112406	104 139	1372 119090	87.0 117	1440 12499	1440 124992	188	217
625					141 189	1168 101382	141 189	1399 121433	142 190	1562 135582	138 185	1829 158757	110 148	1830 158844	1830 158844	189	218
626					166 223	1375 119350	168 224	1658 143914	168 225	1855 161014	169 227	2234 193911	142 190	2350 203980	2350 203980	189	218

Ratio	13
-------	----

Input Speed(R.P.M)	1800		1500		1200		1000		900		750		600		50 and Below	Dimension page	
Output Speed(R.P.M)	138		115		92		77		69		58		46		3.8 and Below		
Frame Size	Input KW HP	Output Torque kgf.m/min.lbs	Input KW HP	Output Torque kgf.m/min.lbs	Input KW HP	Output Torque kgf.m/min.lbs	Input KW HP	Output Torque kgf.m/min.lbs	Input KW HP	Output Torque kgf.m/min.lbs	Input KW HP	Output Torque kgf.m/min.lbs	Input KW HP	Output Torque kgf.m/min.lbs	Output Torque kgf.m/min.lbs	H	V
607	0.24 0.32	1.60 139	0.24 0.32	1.88 163	0.20 0.27	1.98 172	0.18 0.24	2.10 182	0.16 0.21	2.16 187	0.15 0.20	2.30 200	0.12 0.16	2.46 214	2.5 217	180	209
608	0.40 0.54	2.60 226	0.40 0.54	3.12 271	0.39 0.52	3.79 329	0.36 0.48	4.29 372	0.34 0.46	4.42 384	0.30 0.40	4.70 408	0.26 0.35	5.01 435	5.1 443	180	209
609	1.20 1.61	7.81 678	1.2 1.61	9.42 818	1.03 1.38	10.1 877	0.89 1.19	10.5 911	0.84 1.13	10.9 946	0.70 0.94	10.9 946	0.56 0.75	11.0 955	11 955	181	210
610	2.64 3.54	17.2 1493	2.66 3.57	20.8 1805	2.13 2.86	20.8 1850	1.77 2.37	20.8 1805	1.59 2.13	20.8 1805	1.33 1.78	20.8 1805	10.7 1.436	21.0 1823	21 1823	181	210
611	4.98 6.52	31.7 2752	4.88 6.54	38.2 3316	4.19 5.62	41.0 3559	3.67 4.92	43.1 3741	3.37 4.52	44.0 3819	3.00 4.02	4609 4071	2.56 3.43	50.2 4357	51 4427	182	211
612	5.00 6.70	32.6 2830	5.00 6.70	39.1 3394	4.30 5.77	42.1 3654	3.82 5.12	44.8 3889	3.54 4.75	46.2 4010	3.06 4.10	47.9 4158	2.58 3.46	50.5 4383	51 4427	182	211
613	9.25 12.4	60.3 5234	9.21 12.4	72.1 6258	7.84 10.5	76.7 6658	6.54 8.77	76.8 6666	5.90 7.91	77.0 6684	4.92 6.60	77.0 6684	3.94 5.28	77.0 6684	77 6684	183	212
614	9.74 13.1	63.5 5512	9.72 13.0	76.1 6605	8.29 11.1	81.1 7039	7.38 9.90	86.7 7526	6.94 9.31	90.5 7855	6.02 8.07	94.3 8185	5.11 6.85	100 8680	103 8940	183	212
615	10.2 13.7	121 10502.8	10.3 13.8	147 12759.6	8.72 11.7	168 14582.4	7.66 10.3	168 14582.4	7.06 9.47	168 14582.4	6.16 8.26	168 14582.4	5.26 7.05	168 14582.4	168 14582.4	184	213
616	17.0 22.8	133 11544.4	17.0 22.8	160 13888	14.6 19.6	175 15190	12.9 17.3	175 15190	11.9 16.0	175 15190	10.5 14.1	175 15190	9.05 12.1	175 15190	175 15190	184	213
617	26.8 35.9	175 15190	26.7 35.8	209 18141	22.6 30.3	221 19183	20.4 27.4	239 20745	18.8 25.2	245 21266	16.6 22.3	260 22568	14.2 19.0	278 24130	278 24130	185	214
618	33.0 44.2	215 18662	33.1 44.4	259 22481	31.6 42.4	309 26821	27.9 37.4	328 28470	26.0 34.9	339 29425	22.9 30.7	358 31074	319.5 382	332 3158	400 34720	185	214
619	42.3 56.7	276 23957	49.9 53.5	312 27082	38.6 51.8	378 32810	34.1 45.7	400 34720	31.5 42.2	411 35675	27.8 37.3	436 37845	23.8 31.9	466 40449	690 59892	186	215

Ratio	15
-------	----

Input Speed(R.P.M)	1800		1500		1200		1000		900		750		600		50 and Below	Dimension page	
Output Speed(R.P.M)	120		100		80		67		60		50		40		3.3 and Below		
Frame Size	Input KW HP	Output Torque kgf.m/min.lbs	Input KW HP	Output Torque kgf.m/min.lbs	Input KW HP	Output Torque kgf.m/min.lbs	Input KW HP	Output Torque kgf.m/min.lbs	Input KW HP	Output Torque kgf.m/min.lbs	Input KW HP	Output Torque kgf.m/min.lbs	Input KW HP	Output Torque kgf.m/min.lbs	Output Torque kgf.m/min.lbs	H	V
607	0.24 0.32	1.77 154	0.24 0.32	2.14 186	0.20 0.27	2.32 201	0.18 0.24	2.44 212	0.17 0.23	2.50 217	0.14 0.19	2.50 217	0.11 0.15	2.50 217	2.5 217	180	209
608	0.40 0.54	3.00 260	0.40 0.54	3.60 312	0.39 0.52	4.40 382	0.37 0.50	4.99 433	0.34 0.46	5.10 443	0.28 0.38	5.10 443	0.23 0.31	5.10 443	5.1 443	180	209
609	1.04 1.39	7.80 677	1.05 1.41	9.51 825	0.90 1.21	10.2 835	0.80 1.07	10.9 946	0.76 0.99	11.2 972	0.66 0.88	11.9 1033	0.66 0.88	12.0 1042	11 955	181	210
610	2.72 3.65	20.5 1779	2.74 3.67	24.7 2144	2.30 3.08	26.0 2257	1.92 2.57	26.0 2257	1.73 2.32	26.0 2257	1.44 1.93	26.0 2257	1.15 1.54	26.0 2257	21 1823	181	210
611	4.82 6.46	36.3 3151	4.84 6.49	43.7 3793	4.16 5.58	46.9 4071	3.66 4.91	49.6 4305	3.39 4.55	51.0 4427	2.82 3.78	51.0 4427	2.26 3.03	51.0 4427	51 4427	182	211
612	4.94 6.62	37.2 3229	4.95 6.64	44.7 3880	4.26 5.71	48.1 4175	3.76 5.04	50.9 4418	3.39 4.55	51.0 4427	2.82 3.78	51.0 4427	2.26 3.03	51.0 4427	51 4427	182	211
613	7.60 10.2	57.2 4965	7.64 10.2	69.0 5989	6.56 8.80	74.1 6432	5.68 7.62	77.0 6684	5.12 6.87	77.0 6684	4.26 5.71	77.0 6684	3.41 4.57	77.0 6684	77 6684	183	212
614	9.16 12.3	68.9 5980	9.14 12.2	82.5 7161	7.86 10.5	88.7 7699	6.93 9.29	93.8 8142	6.49 8.70	97.7 8480	5.70 7.64	103 8940	4.56 6.12	103 8940	103 8940	183	212
615	9.87 13.2	133 11544.4	9.91 13.3	168 14582.4	8.52 11.4	168 14582.4	7.53 10.1	168 14582.4	6.84 9.17	168 14582.4	5.70 7.64	168 14582.4	4.56 6.12	168 14582.4	168 14582.4	184	213
616	15.0 20.1	146 12672.8	15.0 20.1	175 15190	12.8 17.2	175 15190	11.2 15.0	175 15190	10.4 13.9	175 15190	9.30 12.5	175 15190	7.84 10.5	175 15190	175 15190	184	213
617	22.8 30.6	172 14930	22.9 30.7	207 17988	19.6 26.3	221 19183	17.3 23.2	234 20311	16.0 21.4	241 20919	14.1 18.9	255 22134	12.1 16.2	273 23964	278 24130	185	214
618	30.0 40.2	226 19617	30.3 40.6	273 23696	23.7 31.8	297 23346	22.8 30.6	209 26821	21.3 28.6	220 27766	18.7 25.1	338 29338	16.0 21.4	362 31422	400 34720	185	214
619	42.5 57.0	320 27776	42.6 57.1	385 33418	38.5 51.6	435 37758	34.0 45.6	461 40015	31.6 42.4	475 41230	28.0 37.5	505 43834	23.9 32.0	539 46785	690 59892	186	215
620	58.1 77.9	437 37932	58.1 77.9	525 45570	51.9 69.6	586 50865	45.9 61.6	622 53990	42.8 57.4	64.4 55899	37.8 50.7	682 59198	30.8 41.3	695 60326	695 60326	186	215



Input Speed(R.P.M)	1800		1500		1200		1000		900		750		600		50 and Below	Dimension page	
Output Speed(R.P.M)	120		100		80		67		60		50		40		4.5 and Below	H	V
Frame Size	Input KW HP	Output Torque kgf.m/min.lbs	Input KW HP	Output Torque kgf.m/min.lbs	Input KW HP	Output Torque kgf.m/min.lbs	Input KW HP	Output Torque kgf.m/min.lbs	Input KW HP	Output Torque kgf.m/min.lbs	Input KW HP	Output Torque kgf.m/min.lbs	Input KW HP	Output Torque kgf.m/min.lbs	Output Torque kgf.m/min.lbs	H	V
621	71.0 952	534 46351	71.3 95.6	644 55899	65.6 88.0	740 64232	8580 77.8	786 68225	54.1 72.6	814 70655	47.6 63.8	860 74648	38.1 51.1	860 74648	860 74648	187	216
622	900 121	677 58764	90.2 121	815 70742	81.9 110	925 80290	72.3 97.0	979 84977	67.0 90.0	1009 87581	58.9 79.0	1065 92442	50.4 67.6	1065 92442	1140 98952	187	216
623					92.6 124	1045 90706	92.8 124	1257 109108	82.6 119	1334 115791	78.1 105	1410 124992	63.8 85.6	1410 124992	1440 124992	188	217
624					114 153	1284 11451	122 164	1647 142960	111 149	1665 144522	97.4 131	1760 152768	109 152768	1760 152768	1830 158844	188	217
625					138 185	1560 135408	139 186	1887 163792	137 184	2057 178548	119 160	2155 187054	100 134	2155 187054	2350 203980	189	218
626					168 225	1901 165007	170 228	2300 199640	162 228	2555 221774	162 217	2925 253890	135 181	2925 253890	3050 364740	189	218

Ratio 17

Input Speed(R.P.M)	1800		1500		1200		1000		900		750		600		50 and Below	Dimension page	
Output Speed(R.P.M)	106		88		71		59		53		44		35		2.9 and Below	H	V
Frame Size	Input KW HP	Output Torque kgf.m/min.lbs	Input KW HP	Output Torque kgf.m/min.lbs	Input KW HP	Output Torque kgf.m/min.lbs	Input KW HP	Output Torque kgf.m/min.lbs	Input KW HP	Output Torque kgf.m/min.lbs	Input KW HP	Output Torque kgf.m/min.lbs	Input KW HP	Output Torque kgf.m/min.lbs	Output Torque kgf.m/min.lbs	H	V
607	0.24 0.32	2.02 175	0.24 0.32	2.45 213	0.20 0.27	2.50 217	0.16 0.21	2.50 217	0.15 0.20	2.50 217	0.12 0.16	2.50 217	0.12 0.13	2.50 217	2.5 217	180	209
608	0.40 0.54	3.40 295	0.40 0.54	4.08 354	0.39 0.52	5.02 436	0.33 0.44	5.10 443	0.30 0.40	5.10 443	0.25 0.34	5.10 443	0.20 0.27	5.10 443	5.1 443	180	209
609	1.09 1.46	9.29 806	1.07 1.43	11.0 955	0.93 1.25	11.9 1033	0.81 1.09	12.5 1085	0.76 1.02	13.0 1128	0.64 0.86	13.0 1128	0.51 0.68	13.0 1128	13 1128	181	210
610	2.05 2.75	17.5 1519	2.09 2.80	21.4 1858	1.79 2.40	22.9 1988	1.58 2.12	24.2 2100	1.48 1.98	25.3 2196	1.27 1.70	25.3 2196	1.02 1.37	26.0 2257	26 2257	181	210
611	4.60 6.17	39.2 3402	4.68 6.28	47.9 4158	3.99 5.35	51.0 4427	3.32 4.45	51.0 4427	2.99 4.01	51.0 4427	2.49 3.34	51.0 4427	1.99 2.67	51.0 4427	51 4427	182	211
612	4.97 6.66	42.4 3680	4.98 6.68	51.0 4427	3.99 5.35	51.0 4427	3.32 4.45	51.0 4427	2.99 4.01	51.0 4427	2.49 3.34	51.0 4427	1.99 2.67	51.0 4427	51 4427	182	211
613	7.06 9.47	60.2 5225	7.04 9.44	72.1 6258	6.00 8.05	76.8 6666	5.02 6.73	77.0 6684	4.51 6.05	77.0 6684	3.76 5.04	77.0 6684	3.01 4.04	77.0 6684	77 6684	183	212
614	9.03 12.1	77.0 6684	9.06 12.1	92.7 8046	7.82 10.5	100 8680	6.71 9.00	103 8940	6.04 8.10	103 8940	5.03 6.74	103 8940	4.02 5.39	103 8940	103 8940	183	212
615	9.04 12.1	113 9808.4	9.17 12.2	136 11804.8	7.82 10.5	168 14582.4	6.71 9.00	168 14582.4	6.04 8.10	168 14582.4	5.03 6.74	168 14582.4	4.02 5.39	168 14582.4	168 14582.4	184	213
616	14.9 20.0	115 9982	15.0 20.1	140 12152	12.8 17.2	172 14929.6	11.4 15.3	175 15190	10.6 14.2	175 15190	8.94 12.0	175 15190	7.15 9.59	175 15190	175 15190	184	213
617	19.3 25.9	165 14322	19.3 25.9	198 17186	16.6 22.3	212 18402	14.6 19.6	225 19530	13.5 18.1	231 20051	12.0 16.1	245 21266	10.3 13.8	264 22915	278 24130	185	214
618	29.8 40.0	254 22047	30.0 40.2	307 26648	25.5 34.2	326 28297	22.6 30.3	347 30120	20.9 28.0	357 30988	18.5 24.8	378 32810	15.8 21.2	405 35154	410 35588	185	214
619	42.7 57.3	364 31595	42.9 57.5	439 38105	38.8 52.0	497 43140	34.1 45.7	523 45396	31.6 42.4	540 46872	27.9 37.4	571 49563	23.9 32.0	611 53035	710 61628	186	215

Ratio 21

Input Speed(R.P.M)	1800		1500		1200		1000		900		750		600		50 and Below	Dimension page	
Output Speed(R.P.M)	86		71		57		48		43		36		29		2.4 and Below	H	V
Frame Size	Input KW HP	Output Torque kgf.m/min.lbs	Input KW HP	Output Torque kgf.m/min.lbs	Input KW HP	Output Torque kgf.m/min.lbs	Input KW HP	Output Torque kgf.m/min.lbs	Input KW HP	Output Torque kgf.m/min.lbs	Input KW HP	Output Torque kgf.m/min.lbs	Input KW HP	Output Torque kgf.m/min.lbs	Output Torque kgf.m/min.lbs	H	V
607	0.20 0.27	2.06 179	0.20 0.27	2.50 217	0.16 0.21	2.50 217	0.13 0.17	2.50 217	0.12 0.16	2.50 217	0.10 0.13	2.50 217	0.08 0.11	2.50 217	2.5 217	180	209
608	0.40 0.54	4.20 364	0.40 0.54	5.04 437	0.32 0.43	5.10 443	0.27 0.36	5.10 443	0.24 0.32	5.10 443	0.20 0.27	5.10 443	0.16 0.21	5.10 443	5.1 443	180	209
609	1.00 1.34	10.5 911	0.99 1.33	12.5 1085	0.82 1.10	13.0 1128	0.68 0.91	13.0 1128	0.62 0.83	13.0 1128	0.51 0.68	13.0 1128	0.471 0.55	13.0 1128	13 1128	181	210
610	2.01 2.70	21.2 1840	2.02 2.71	25.5 2213	1.64 2.20	26.0 2257	1.73 2.257	26.0 2257	1.23 1.65	26.0 2257	1.03 1.38	26.0 2257	0.82 1.10	26.0 2257	26 2257	181	210
611	4.00 5.36	42.2 3663	4.03 5.40	51.0 4427	3.23 4.33	51.0 4427	2.69 3.61	51.0 4427	2.42 3.24	51.0 4427	2.02 2.71	51.0 4427	1.61 2.16	51.0 4427	51 4427	182	211
612	4.00 5.36	42.2 3663	4.03 5.40	51.0 4427	3.23 4.33	51.0 4427	2.69 3.61	51.0 4427	2.42 3.24	51.0 4427	2.02 2.71	51.0 4427	1.61 2.16	51.0 4427	51 4427	182	211
613	6.02 8.07	63.4 5503	6.05 8.11	76.5 6640	4.87 6.53	77.0 6684	4.06 5.44	77.0 6684	3.65 4.89	77.0 6684	3.04 4.08	103 8940	2.44 3.27	77.0 6684	77 6684	183	212
614	6.65 8.92	70.1 6035	6.70 8.98	84.7 7352	5.73 7.68	90.6 7864	5.06 6.78	96.0 8333	4.70 6.30	99 8593	4.07 5.46	103 8940	3.26 4.37	103 8940	103 8940	183	212
615	7.04 9.44	136 11804.8	7.08 9.49	148 12846.4	6.06 8.13	168 14582.4	5.33 7.15	168 14582.4	4.89 6.56	168 14582.4	4.07 5.46	168 14582.4	3.26 4.37	168 14582.4	168 14582.4	184	213
616	13.3 17.8	140 12152	13.2 17.7	170 14756	11.4 15.3	175 15190	9.65 12.9	175 15190	8.68 11.6	175 15190	7.24 9.71	175 15190	5.79 7.76	175 15190	175 15190	184	213
617	18.4 24.7	194 16839	18.5 24.8	234 20311	15.9 21.3	251 21787	13.9 18.6	264 22915	13.0 17.4	274 23783	11.0 14.8	410 35588	8.80 11.8	278 24130	278 24130	185	214
618	26.9 36.1	283 24564	26.9 36.1	340 29512	23.1 31.0	265 31682	20.4 27.4	267 33592	19.0 25.5	400 34720	16.2 21.7	569 49389	13.0 17.4	410 35588	410 35588	185	214
619	36.2 48.5	381 33071	36.1 48.4	457 39668	31.1 41.7	492 42706	27.3 36.6	517 44876	25.4 34.1	535 46438	22.5 30.2	569 49389	19.3 25.9	610 52948	730 63364	186	215
620	46.0 61.7	485 42098	46.3 62.1	585 50778	39.5 53.5	630 54684	35.2 47.2	667 57896	32.7 43.8	690 59892	28.8 38.6	729 63277	23.1 31.0	730 63364	970 84196	186	215



Input Speed(R.P.M)	1800		1500		1200		1000		900		750		600		50 and Below	Dimension page	
Output Speed(R.P.M)	86		71		57		48		43		36		29		2.4 and Below		
Frame Size	Input KW HP	Output Torque kgf.min.lbs	Input KW HP	Output Torque kgf.min.lbs	Input KW HP	Output Torque kgf.min.lbs	Input KW HP	Output Torque kgf.min.lbs	Input KW HP	Output Torque kgf.min.lbs	Input KW HP	Output Torque kgf.min.lbs	Input KW HP	Output Torque kgf.min.lbs	Output Torque kgf.min.lbs	H	V
621	59.3 79.5	625 54250	59.5 79.8	752 65274	53.5 71.7	845 73346	47.4 63.6	900 78120	44.2 59.3	932 80898	38.4 51.5	970 84196	30.7 41.2	970 84196	970 84196	187	216
622	69.7 93.5	734 63711	70.3 94.3	889 77165	70.6 94.7	1115 96782	63.6 85.3	1207 104768	59.2 79.4	1248 108326	50.4 67.6	1275 110670	40.3 54.0	1275 110670	1275 110670	187	216
623					73.4 98.4	1160 100688	73.8 99.0	1400 121520	68.5 91.9	1444 125339	60.4 81.0	1526 132457	51.4 69.0	1625 141050	1625 141050	188	217
624					94.8 127	1498 130026	94.8 127	1800 156240	86.8 116	1830 158844	76.6 103	1938 168218	64.9 87.0	2050 177940	2050 177940	188	217
625					117 157	1847 160320	116 156	2200 190960	116 156	2445 212226	103 138	2600 225680	83.8 112	2650 230020	2650 230020	189	218
626					141 189	2225 193130	142 190	2685 233058	142 190	2998 260226	132 177	3334 289291	112 150	3550 308140	3550 308140	189	218

Ratio 25

Input Speed(R.P.M)	1800		1500		1200		1000		900		750		600		50 and Below	Dimension page	
Output Speed(R.P.M)	72		60		48		40		36		30		24		2.0 and Below		
Frame Size	Input KW HP	Output Torque kgf.min.lbs	Input KW HP	Output Torque kgf.min.lbs	Input KW HP	Output Torque kgf.min.lbs	Input KW HP	Output Torque kgf.min.lbs	Input KW HP	Output Torque kgf.min.lbs	Input KW HP	Output Torque kgf.min.lbs	Input KW HP	Output Torque kgf.min.lbs	Output Torque kgf.min.lbs	H	V
607	0.14 0.19	1.76 153	0.14 0.19	2.10 182	0.12 0.16	2.24 194	0.10 0.13	2.39 207	0.10 0.13	2.46 214	0.08 0.11	2.50 217	0.07 0.09	2.50 217	25 217	180	209
608	0.25 0.34	3.10 269	0.25 0.34	3.74 325	0.21 0.28	3.99 346	0.19 0.25	4.24 368	0.17 0.23	4.38 38.0	0.15 0.20	4.64 399	0.13 0.17	4.96 430	5.1 443	180	209
609	0.75 1.00	9.45 820	1.75 1.00	11.4 990	0.85 0.87	12.3 1068	0.56 0.75	12.7 1102	0.52 0.70	13.0 1128	0.43 0.58	13.0 1128	0.34 0.46	13.0 1128	13 1128	181	210
610	1.47 1.97	18.4 1597	1.44 1.93	21.7 1884	1.24 1.66	23.4 2031	1.08 1.45	24.5 2127	1.02 1.37	25.5 2213	0.86 1.15	26.0 2257	0.69 0.92	26.0 2257	26 2257	181	210
611	3.19 4.28	40.0 3472	3.20 4.29	48.2 4184	2.71 3.63	51.0 4427	2.26 3.03	51.0 4427	2.03 2.72	51.0 4427	1.69 2.27	51.0 4427	1.36 1.82	51.0 4427	51 4427	182	211
612	3.34 4.48	41.9 3637	3.35 4.49	50.4 4375	2.71 3.63	51.0 4427	2.26 3.03	51.0 4427	2.03 2.72	51.0 4427	1.69 2.27	51.0 4427	1.36 1.82	51.0 4427	51 4427	182	211
613	5.08 6.81	63.7 5529	5.08 6.81	76.5 6640	4.09 5.48	77.0 6684	3.41 4.57	77.0 6684	3.07 4.12	77.0 6684	2.56 3.43	77.0 6684	2.05 2.75	77.0 6684	77 6684	183	212
614	5.82 7.8	73.0 6336	5.84 7.83	87.9 7630	5.00 6.70	94.0 8159	4.43 5.94	100 8680	4.11 5.51	103 8940	3.42 4.59	103 8940	2.74 3.67	103 8940	103 8940	183	212
615	6.94 9.31	115 9982	6.71 9.00	148 12846.4	5.48 7.35	168 14582.4	4.56 6.12	168 14582.4	4.11 5.51	168 14582.4	3.42 4.59	168 14582.4	2.74 3.67	168 14582.4	168 14582.4	184	213
616	11.6 15.6	127 11023.6	11.6 15.6	153 13280.4	9.73 13.0	175 15190	8.11 10.9	175 15190	7.30 9.79	175 15190	6.08 8.15	175 15190	4.86 6.52	175 15190	175 15190	184	213
617	15.6 20.9	196 17013	15.5 20.8	234 20311	13.3 17.8	250 21700	11.7 15.7	265 23002	10.9 14.6	274 23783	9.24 12.4	278 24130	9.39 12.6	278 24130	278 24130	185	214
618	22.8 30.6	286 24825	22.8 30.6	344 29859	19.5 26.2	367 31856	17.2 23.1	388 33678	16.1 21.6	404 35067	13.6 18.2	410 35588	10.9 14.6	410 35588	410 35588	185	214
619	34.2 45.9	429 37237	34.4 46.1	517 44876	29.4 39.4	554 48047	25.9 34.7	585 50778	24.0 32.2	603 52340	21.1 28.3	636 55205	18.2 24.4	683 59284	730 63364	186	215

Ratio 29

Input Speed(R.P.M)	1800		1500		1200		1000		900		750		600		50 and Below	Dimension page	
Output Speed(R.P.M)	62		52		41		34		31		26		21		1.7 and Below		
Frame Size	Input KW HP	Output Torque kgf.min.lbs	Input KW HP	Output Torque kgf.min.lbs	Input KW HP	Output Torque kgf.min.lbs	Input KW HP	Output Torque kgf.min.lbs	Input KW HP	Output Torque kgf.min.lbs	Input KW HP	Output Torque kgf.min.lbs	Input KW HP	Output Torque kgf.min.lbs	Output Torque kgf.min.lbs	H	V
607	0.14 0.19	1.98 172	0.13 0.17	2.35 204	0.11 0.15	2.48 215	0.10 0.13	2.50 217	0.08 0.11	2.50 217	0.07 0.09	2.50 217	0.06 0.08	2.50 217	2.50 217	180	209
608	0.24 0.32	3.52 306	0.24 0.32	4.25 369	0.21 0.28	4.55 395	0.18 0.24	4.83 419	0.17 0.23	5.09 442	0.14 0.19	5.09 442	0.12 0.16	5.09 442	5.1 443	180	209
609	0.68 0.91	9.06 8.59	0.67 0.90	11.7 1016	0.57 0.76	12.5 1085	0.50 0.67	13.0 1128	0.45 0.60	13.0 1128	0.37 0.50	13.0 1128	0.31 0.40	13.0 1128	13 1128	181	210
610	1.38 1.85	20.1 1745	1.38 1.85	24.1 2092	1.17 1.57	25.5 2213	1.00 1.34	25.9 2248	0.89 1.19	26.0 2257	0.74 1.00	26.0 2257	0.60 0.80	26.0 2257	26 2257	181	210
611	2.84 3.81	41.3 3585	2.85 3.82	49.7 4314	2.34 3.14	51.0 4427	1.95 2.62	51.0 4427	1.75 2.35	51.0 4427	1.46 1.96	51.0 4427	1.17 1.57	51.0 4427	51 4427	182	211
612	2.84 3.81	41.4 3594	2.86 3.84	50.0 4340	2.33 3.12	50.9 4418	1.95 2.62	51.0 4427	1.75 2.35	51.0 4427	1.46 1.96	51.0 4427	1.17 1.57	51.0 4427	51 4427	182	211
613	4.41 5.91	64.1 5564	4.41 5.91	77.0 6684	3.53 4.73	77.0 6684	2.94 3.94	77.0 6684	2.65 3.55	77.0 6684	2.20 2.95	77.0 6684	1.76 2.36	77.0 6684	77 6684	183	212
614	4.84 6.49	70.5 6119	4.85 6.50	84.7 7352	4.20 5.63	91.7 7960	3.63 4.87	95.0 8246	3.40 4.56	103 8940	2.95 3.96	103 8940	2.36 3.16	103 8940	103 8940	183	212
615	5.88 7.88	140 12152	5.84 7.83	148 12846.4	4.72 6.33	168 14582.4	3.93 5.27	168 14582.4	3.54 4.75	168 14582.4	2.95 3.96	168 14582.4	2.36 3.16	168 14582.4	168 14582.4	184	213
616	9.69 13.0	158 13714.4	9.68 13.0	173 15016.4	8.34 11.2	175 15190	6.99 9.37	175 15190	6.29 8.44	175 15190	5.24 7.03	175 15190	4.19 5.62	175 15190	175 15190	184	213
617	14.3 19.2	208 18054	14.3 19.2	250 21700	12.2 16.4	267 23176	10.6 14.2	278 24130	9.55 12.8	400 34720	7.96 10.7	410 35588	6.37 8.54	410 35588	410 35588	185	214
618	18.3 24.5	266 23089	18.4 24.7	322 27950	15.9 21.3	348 30206	13.9 18.6	364 31595	12.9 17.3	399 34633	11.4 15.3	396 34373	9.39 12.6	410 35588	183 15884	185	214
619	30.0 40.2	437 37832	30.1 40.4	526 45657	25.8 34.6	563 48868	22.7 30.4	594 51559	21.0 28.2	730 63364	18.6 24.9	730 63364	15.9 21.3	696 60413	278 24130	186	215
620	39.0 52.3	568 49302	39.1 52.4	683 59284	33.4 44.8	728 63190	27.8 37.3	729 63277	25.1 33.7	965 83762	20.9 28.0	730 63364	16.7 22.4	696 60413	410 35588	186	215



Input Speed(R.P.M)	1800		1500		1200		1000		900		750		600		50 and Below	Dimension page	
Output Speed(R.P.M)	62		52		41		34		31		26		21		4.5 and Below		
Frame Size	Input KW HP	Output Torque kgf.m/in.lbs	Input KW HP	Output Torque kgf.m/in.lbs	Input KW HP	Output Torque kgf.m/in.lbs	Input KW HP	Output Torque kgf.m/in.lbs	Input KW HP	Output Torque kgf.m/in.lbs	Input KW HP	Output Torque kgf.m/in.lbs	Input KW HP	Output Torque kgf.m/in.lbs	Output Torque kgf.m/in.lbs	H	V
621	47.8 64.1	695 60326	47.8 64.1	835 72478	41.7 55.9	910 78988	36.7 49.2	962 83502	33.2 44.5	965 83762	27.6 37.0	965 83762	22.1 29.6	965 83762	965 83762	187	216
622	53.3 71.5	775 67270	53.3 71.5	934 81071	52.3 70.1	1142 99126	46.2 62.05	1210 105028	43.0 57.7	1250 108500	36.5 48.9	1275 110670	29.2 39.2	1275 110670	1275 110670	187	216
623					55.1 73.9	1202 104334	54.4 74.3	1450 125860	53.4 71.5	1555 134974	46.2 62.0	1615 140182	37.2 49.9	1625 141050	1625 141050	188	217
624					68.3 91.6	1490 129332	68.7 92.1	1799 156153	65.0 87.2	1890 164052	57.3 76.8	2000 173600	47.0 63.0	2050 177940	2050 177940	188	217
625					93.9 126	2049 177853	94.7 127	2470 214396	91.1 122	2650 230020	75.9 102	2650 230020	60.7 81.4	2650 230020	2650 230020	189	218
626					135 181	2949 255973	135 181	3545 30706	122 164	3550 308140	102 137	3550 308140	81.3 109	3550 308140	3550 308140	189	218
627					140 188	3050 264740	140 188	3680 319424	141 189	4099 355793	130 174	4550 394940	112 150	4872 422890	6100 529480	190	219

Ratio 35

Input Speed(R.P.M)	1800		1500		1200		1000		900		750		600		50 and Below	Dimension page	
Output Speed(R.P.M)	51		43		34		29		26		21		17		1.4 and Below		
Frame Size	Input KW HP	Output Torque kgf.m/in.lbs	Input KW HP	Output Torque kgf.m/in.lbs	Input KW HP	Output Torque kgf.m/in.lbs	Input KW HP	Output Torque kgf.m/in.lbs	Input KW HP	Output Torque kgf.m/in.lbs	Input KW HP	Output Torque kgf.m/in.lbs	Input KW HP	Output Torque kgf.m/in.lbs	Output Torque kgf.m/in.lbs	H	V
607	0.12 0.16	2.15 187	0.12 0.16	2.49 216	0.09 0.12	2.50 217	0.08 0.11	2.50 217	0.06 0.08	2.50 217	0.06 0.08	2.50 217	0.05 0.07	2.50 217	2.5 217	180	209
608	0.24 0.32	425 369	0.24 0.32	5.05 438	0.19 0.25	5.10 443	0.16 0.21	5.10 443	0.12 0.16	5.10 443	0.12 0.16	5.10 443	0.10 0.13	5.10 443	5.1 443	180	209
609	0.58 0.78	10.1 877	0.58 0.78	12.2 1059	0.49 0.66	13.0 1128	0.41 0.55	13.0 1128	0.31 0.42	13.0 1128	0.31 0.42	13.0 1128	0.25 0.34	13.0 1128	13 1128	181	210
610	1.03 1.38	18.1 1571	1.02 1.37	21.5 1866	0.87 1.17	24.5 2127	0.78 1.05	25.5 2222	0.62 0.83	26.0 2257	0.62 0.83	26.0 2257	0.49 0.66	26.0 2257	26 2257	181	210
611	2.40 3.22	42.1 3654	2.42 3.27	50.9 4418	1.94 2.60	51.0 4427	1.61 2.16	51.0 4427	1.21 1.62	51.0 4427	1.21 1.62	51.0 4427	0.97 1.30	51.0 4427	51 4427	182	211
612	2.40 3.22	42.1 3654	2.42 3.24	50.9 4418	1.94 2.60	51.0 4427	1.61 2.16	51.0 4427	1.21 1.62	51.0 4427	1.21 1.62	51.0 4427	0.97 1.30	51.0 4427	51 4427	182	211
613	3.62 4.85	635 5512	3.64 4.88	76.7 6658	2.92 3.92	76.8 6666	2.44 3.27	77.0 6684	1.83 2.45	77.0 6684	1.83 2.45	77.0 6684	1.46 1.96	77.0 6684	77 6684	183	212
614	4.61 6.18	81.0 7031	4.63 6.21	97.5 8463	3.91 5.24	103 8940	3.26 4.37	103 8940	2.44 3.27	103 8940	2.44 3.27	103 8940	1.96 2.63	103 8940	103 8940	183	212
615	4.84 6.49	151 13106.8	4.84 6.19	168 14582.4	3.91 5.24	168 14582.4	3.26 4.37	168 14582.4	2.44 3.27	168 14582.4	2.44 3.27	168 14582.4	1.96 2.63	168 14582.4	168 14582.4	184	213
616	8.6 11.5	175 15190	8.64 11.6	175 15190	6.95 9.32	175 15190	5.79 7.76	175 15190	4.34 5.82	175 15190	4.34 5.82	175 15190	3.47 4.65	175 15190	175 15190	184	213
617	12.4 16.6	217 18836	12.5 16.8	228.28	10.5 14.1	277 24044	8.80 11.8	278 24130	6.60 8.85	278 24130	6.60 8.85	278 24130	5.28 7.08	278 24130	278 24130	185	214
618	18.4 24.7	323 28036	18.5 24.8	389 33765	15.5 20.8	409 35501	13.0 17.4	410 35588	9.73 13.0	410 35588	9.73 13.0	410 35588	7.78 10.4	410 35588	410 35588	185	214
619	23.5 31.5	413 35848	23.7 31.8	500 43400	20.3 27.2	535 46438	17.8 23.9	582 50518	14.6 19.6	615 53382	14.6 19.6	615 53382	12.5 16.8	615 53382	730 63364	186	215

Ratio 43

Input Speed(R.P.M)	1800		1500		1200		1000		900		750		600		50 and Below	Dimension page	
Output Speed(R.P.M)	42		35		28		23		21		17		14		1.2 and Below		
Frame Size	Input KW HP	Output Torque kgf.m/in.lbs	Input KW HP	Output Torque kgf.m/in.lbs	Input KW HP	Output Torque kgf.m/in.lbs	Input KW HP	Output Torque kgf.m/in.lbs	Input KW HP	Output Torque kgf.m/in.lbs	Input KW HP	Output Torque kgf.m/in.lbs	Input KW HP	Output Torque kgf.m/in.lbs	Output Torque kgf.m/in.lbs	H	V
607	0.10 0.13	2.10 182		2.50 217	0.08 0.11	2.50 217	0.06 0.08	2.50 217	0.06 0.08	2.50 217	0.05 0.07	2.50 217	0.04 0.05	2.50 217	2.5 217	180	209
608	0.20 0.27	4.25 369		5.10 443	0.16 0.21	5.10 443	0.13 0.17	5.10 443	0.12 0.16	5.10 443	0.10 0.13	5.10 443	0.08 0.11	5.10 443	5.1 443	180	209
609	0.49 0.66	10.6 920		13.0 1128	0.40 0.54	13.0 1128	0.33 0.44	13.0 1126	0.30 0.40	13.0 1128	0.25 0.34	13.0 1128	0.20 0.27	13.0 443	13 1128	181	210
610	0.93 1.25	20.0 1736		24.1 2092	0.80 1.07	25.8 2239	0.67 0.90	25.6 2222	0.60 0.80	26.0 2257	0.50 0.67	26.0 2257	0.40 0.54	13.0 1128	26 2257	181	210
611	1.92 2.57	41.4 3594		49.7 4314	1.58 2.12	51.0 4427	1.31 1.76	51.0 4427	1.18 1.58	51.0 4427	0.98 1.31	51.0 4427	0.79 1.06	26.0 2257	51 4427	182	211
612	1.96 2.63	42.3 3672		50.9 4418	1.58 2.12	51.0 4427	1.31 1.76	51.0 4427	1.18 1.58	51.0 4427	0.98 1.31	51.0 4427	1.19 1.60	51.0 4427	51 4427	182	211
613	2.96 3.97	63.9 5546		76.5 6640	2.38 3.19	77.0 6684	1.98 2.66	77.0 6684	1.78 2.39	77.0 6684	1.49 2.00	77.0 6684	1.59 2.13	51.0 4427	77 6684	183	212
614	3.15 4.22	68.0 5902		81.9 7109	2.71 3.63	87.8 7621	2.39 3.20	103 8940	2.21 2.96	103 8940	1.99 2.67	103 8940	1.59 2.13	51.0 4427	103 8940	183	212
615	3.85 5.16	140 12152		168 14582.4	3.18 4.25	168 14582.4	2.65 3.55	168 14582.4	2.39 3.20	168 14582.4	1.99 2.67	168 14582.4	2.83 3.80	168 14582.4	168 14582.4	184	213
616	6.72 9.01	166 14408.8		173 15016.4	5.66 7.59	173 15016.4	4.71 6.32	173 15016.4	4.24 5.69	173 15016.4	3.53 4.73	173 15016.4	4.30 5.77	173 15016.4	173 15016.4	184	213
617	9.27 12.4	200 17360		241 20919	8.04 10.8	260 22568	7.16 9.60	278 24130	6.44 8.64	410 35588	5.37 7.20	278 24130	6.34 8.50	183 15884	278 24130	185	214
618	14.8 19.8	320 27776		387 33592	12.7 17.0	410 3558	10.6 14.2	410 35588	9.50 12.7	620 53816	7.92 10.6	410 35588	10.8 14.5	278 24130	410 35588	185	214
619	20.8 27.9	449 38973		530 46004	17.6 23.6	568 49302	15.5 20.8	582 50518	14.4 19.3	823 71436	12.7 17.0	656 56961	13.3 17.8	410 35588	730 63364	186	215



Input Speed(R.P.M)	1800		1500		1200		1000		900		750		600		50 and Below	Dimension page	
Output Speed(R.P.M)	42		35		28		23		21		17		14		1.2 and Below		
Frame Size	Input KW HP	Output Torque kgt./min.lbs	Input KW HP	Output Torque kgt./min.lbs	Input KW HP	Output Torque kgt./min.lbs	Input KW HP	Output Torque kgt./min.lbs	Input KW HP	Output Torque kgt./min.lbs	Input KW HP	Output Torque kgt./min.lbs	Input KW HP	Output Torque kgt./min.lbs	Output Torque kgt./min.lbs	H	V
620	27.0 36.2	582 50518	27.3 36.6	706 61281	24.1 32.3	780 67704	20.8 27.9	807 70048	19.1 25.6	823 71436	16.5 22.1	854 74127	13.3 17.8	860 74648	860 74648	186	215
621	37.1 49.8	800 69440	37.3 50.0	9.65 83752	31.8 42.6	1028 89230	27.6 37.0	1072 93050	25.3 33.9	1092 94786	21.8 29.2	1130 98084	17.6 23.6	1140 98952	1140 98952	187	216
622	45.7 61.3	985 85498	45.7 61.3	1183 102684	39.2 52.6	1270 110236	33.9 45.5	1315 114142	31.1 41.7	1341 116399	26.8 35.9	1385 120218	22.3 29.9	1440 124992	1440 124992	187	216
623					42.8 57.4	1386 120305	42.8 57.4	1660 144088	39.8 53.4	1715 148862	35.0 46.9	1810 157108	28.1 37.7	1820 157976	1820 158844	188	217
624					55.8 74.8	1806 156761	55.8 74.8	2165 187922	51.0 68.4	2200 190960	43.8 58.7	2270 197036	35.8 48.0	2320 201376	2350 203980	188	217
625					68.5 91.9	2217 192436	68.1 91.3	2645 229586	68.3 91.6	2945 255526	58.9 79.0	3050 264740	47.1 63.2	3050 264740	3050 264740	189	218
626					94.2 126	3050 264740	94.2 126	3660 317688	88.5 119	3920 331576	77.0 103	3986 345985	63.8 85.5	4100 355880	4100 355880	189	218
627					125 168	4050 351540	126 169	4900 425320	118 158	5070 440076	104 139	5360 465248	89.58 120	5790 502572	6100 529480	190	219

Ratio 51

Input Speed(R.P.M)	1800		1500		1200		1000		900		750		600		50 and Below	Dimension page	
Output Speed(R.P.M)	35		29		24		20		18		15		12		0.98 and Below		
Frame Size	Input KW HP	Output Torque kgt./min.lbs	Input KW HP	Output Torque kgt./min.lbs	Input KW HP	Output Torque kgt./min.lbs	Input KW HP	Output Torque kgt./min.lbs	Input KW HP	Output Torque kgt./min.lbs	Input KW HP	Output Torque kgt./min.lbs	Input KW HP	Output Torque kgt./min.lbs	Output Torque kgt./min.lbs	H	V
608	0.12 0.16	3.07 266	0.12 0.16	3.70 321	0.10 0.13	4.01 348	0.09 0.12	4.22 366	0.08 0.11	4.37 37.9	0.08 0.11	4.63 4.02	0.06 0.08	4.96 430	5.1 443	180	209
609	0.36 0.48	9.30 807	0.36 0.48	11.0 955	0.31 0.42	11.9 1033	0.27 0.36	12.3 1068	0.25 0.34	13.0 1128	0.21 0.28	13.0 1128	0.17 0.23	13.0 1128	13 1128	180	209
610	0.66 0.88	17.0 1476	0.67 0.90	20.5 1779	0.57 0.76	21.9 1901	0.50 0.67	23.1 2005	0.48 0.64	24.4 2118	0.48 0.64	25.5 2213	0.34 0.46	26.0 2257	26 2257	181	210
611	1.87 2.51	47.9 4158	1.66 2.23	50.9 4418	1.33 1.78	51.0 4427	1.11 1.49	51.0 4427	1.00 1.34	51.0 4427	0.83 1.11	51.0 4427	0.66 0.88	51.0 4427	51 4427	181	210
612	1.87 2.51	47.9 4158	1.66 2.23	50.9 4418	1.33 1.78	51.0 4427	1.11 1.49	51.0 4427	1.00 1.34	51.0 4427	0.83 1.11	51.0 4427	0.66 0.88	51.0 4427	77 6684	182	211
613	2.52 3.38	64.5 4163	2.50 3.35	76.7 6658	2.00 2.68	76.9 6675	1.67 2.24	77.0 6684	1.50 2.01	77.0 6684	1.25 1.68	77.0 6684	1.00 1.34	77.0 6684	103 8940	182	211
614	2.94 3.94	75.2 6527	2.97 3.98	91.2 7916	2.53 3.39	97.0 8420	2.21 2.96	102 8854	2.014 2.70	103 8940	1.68 2.25	103 8940	1.34 1.80	103 8940	103 8940	183	212
615	3.40 4.56	140 12152	3.32 4.45	168 14582.4	2.66 3.57	168 14582.4	2.24 3.00	168 14582.4	2.01 2.70	168 14582.4	1.68 2.25	168 14582.4	1.34 1.80	168 14582.4	168 14582.4	183	212
616	5.67 7.60	151 13106.8	5.70 7.64	175 15190	4.72 6.33	175 15190	3.95 5.30	175 15190	3.58 4.80	175 15190	2.98 4.00	175 15190	2.38 3.19	175 15190	175 15190	184	213
617	8.32 11.2	213 18488	8.34 11.2	256 22221	7.11 9.53	273 23696	6.04 8.10	278 24130	5.43 7.28	278 24130	4.53 6.07	278 24130	3.62 4.85	278 24130	278 24130	184	213
618	11.4 15.3	291 25259	11.4 15.3	350 30380	9.69 13.0	372 32290	8.90 11.9	410 35588	8.01 10.7	410 35588	6.68 8.96	410 35588	5.34 7.16	410 35588	410 35588	185	214
619	18.0 24.1	460 39928	17.9 24.0	549 47653	15.3 20.5	587 50952	13.5 18.1	620 53816	12.5 16.8	640 55552	11.1 14.9	730 63364	9.51 12.7	730 63364	730 63364	185	214

Ratio 59

Input Speed(R.P.M)	1800		1500		1200		1000		900		750		600		50 and Below	Dimension page	
Output Speed(R.P.M)	31		25		20		17		15		13		10		0.86 and Below		
Frame Size	Input KW HP	Output Torque kgt./min.lbs	Input KW HP	Output Torque kgt./min.lbs	Input KW HP	Output Torque kgt./min.lbs	Input KW HP	Output Torque kgt./min.lbs	Input KW HP	Output Torque kgt./min.lbs	Input KW HP	Output Torque kgt./min.lbs	Input KW HP	Output Torque kgt./min.lbs	Output Torque kgt./min.lbs	H	V
608	0.12 0.16	3.45 299	0.12 0.16	4.15 360	0.10 0.13	4.45 386	0.09 0.12	4.70 408	0.08 0.11	4.87 423	0.07 0.09	5.10 443	0.06 0.08	5.10 443	5.1 4436	180	207
609	0.36 0.44	9.71 843	0.36 0.44	11.6 1007	0.28 0.38	12.5 1085	0.24 0.32	13.0 1128	0.22 0.30	13.0 1128	0.18 0.24	13.0 1128	0.15 0.20	13.0 1128	13 1128	181	210
610	0.61 0.82	18.0 1562	0.60 0.80	21.5 1866	0.52 0.70	23.3 2022	0.45 0.60	24.2 2100	0.43 0.58	25.4 2205	0.37 0.50	26.0 2257	0.29 0.39	26.0 2257	26 2257	181	210
611	1.38 1.85	40.8 3541	1.37 1.84	48.7 4227	1.14 1.53	50.8 4409	0.96 1.29	51.0 4427	0.86 1.15	51.0 4427	0.72 0.96	51.0 4427	0.57 0.76	51.0 4427	51 4427	182	211
612	1.38 1.85	41.0 3559	1.38 1.85	48.9 4244	1.15 1.54	50.9 4418	0.96 1.29	51.0 4427	0.86 1.15	51.0 4427	0.72 0.96	51.0 4427	0.57 0.76	51.0 4427	51 4427	182	211
613	2.16 2.90	64.0 5555	2.15 2.88	76.4 6632	1.73 2.32	76.8 6666	1.44 1.93	76.9 6675	1.30 1.74	77.0 6684	1.08 1.45	77.0 6684	0.87 1.17	77.0 6684	77 6684	183	212
614	2.34 3.81	84.0 7291	2.80 3.75	99.6 8645	2.25 3.02	100 8680	1.93 2.59	103 8940	1.74 2.33	103 8940	1.45 1.94	103 8940	1.16 1.56	103 8940	103 8940	183	212
615	2.90 3.89	121 10502.8	2.82 3.78	151 13106.8	2.25 3.02	168 14582.4	1.93 2.59	168 14582.4	1.74 2.33	168 14582.4	1.45 1.94	168 14582.4	1.16 1.56	168 14582.4	168 14582.4	184	213
616	4.90 6.57	135 11718	4.96 6.65	163 14148.4	4.10 5.50	175 15190	3.43 4.60	175 15190	3.09 4.14	175 15190	2.58 3.46	175 15190	2.06 2.76	175 15190	175 15190	184	213
617	7.23 9.70	214 18575	7.29 9.78	259 22481	6.08 8.15	270 23436	5.22 7.00	278 24130	4.70 6.30	278 24130	3.91 5.24	278 24130	3.13 4.20	278 24130	278 24130	185	214
618	9.73 13.0	288 24998	9.85 13.2	350 30380	8.11 10.9	360 31248	7.08 9.49	377 32724	6.40 8.58	379 32897	5.67 7.60	403 34980	4.62 6.20	410 35588	410 35588	185	214
619	15.5 20.8	460 39928	15.5 20.8	550 47740	13.2 17.7	585 50778	11.8 15.8	630 54684	11.0 14.8	650 56420	9.66 13.0	686 59545	8.22 11.0	730 63364	730 63364	186	215
620	19.2 25.7	570 49476	19.1 25.6	680 59024	17.9 24.0	794 68919	15.4 20.6	820 71176	14.2 19.0	843 73172	12.1 16.2	860 74648	9.68 13.0	860 74648	860 74648	186	215



Input Speed(R.P.M)	1800		1500		1200		1000		900		750		600		50 and Below	Dimension page	
Output Speed(R.P.M)	31		25		20		17		15		13		10		0.86 and Below		
Frame Size	Input KW HP	Output Torque kgf.m/min.lbs	Input KW HP	Output Torque kgf.m/min.lbs	Input KW HP	Output Torque kgf.m/min.lbs	Input KW HP	Output Torque kgf.m/min.lbs	Input KW HP	Output Torque kgf.m/min.lbs	Input KW HP	Output Torque kgf.m/min.lbs	Input KW HP	Output Torque kgf.m/min.lbs	Output Torque kgf.m/min.lbs	H	V
621	27.7 37.1	821 71263	27.8 37.3	989 85845	23.9 32.0	1053 92268	20.4 27.4	1090 94612	18.8 25.2	1110 96348	16.0 21.4	1140 98952	12.8 17.2	1140 98952	1140 98952	187	216
622	33.3 44.6	986 85585	33.4 44.8	1185 102858	28.6 38.4	1272 110410	24.7 33.1	1315 114142	22.7 30.4	1345 116746	19.5 26.2	1386 120305	16.2 21.7	1440 124992	1440 124992	187	216
623					29.9 40.1	1326 115097	30.0 40.2	1600 138880	27.5 36.9	1629 141397	23.9 32.0	1700 147560	20.2 27.1	1798 156066	1830 158844	188	217
624					38.2 51.2	1697 147300	38.3 51.4	2040 17707	35.1 47.0	2080 180544	30.4 40.8	2160 187488	25.4 34.1	2256 195821	2350 203980	188	217
625					55.2 74.0	2450 212660	55.3 74.2	2945 255626	51.4 69.0	3040 263872	42.9 57.5	3050 264740	34.3 46.0	3050 264740	3050 264740	189	218
626					74.8 100	3323 288438	75.1 101	4000 347200+	69.1 92.7	4090 355012	57.6 77.2	4095 355446	46.2 62.0	4100 35580	4100 355880	189	218
627					100 134	4440 385392	100 134	5330 462644	92.7 124	5490 476532	81.6 109	5800 503440	68.7 92.1	6100 529480	6100 529480	190	219

Ratio 71

Input Speed(R.P.M)	1800		1500		1200		1000		900		750		600		50 and Below	Dimension page	
Output Speed(R.P.M)	25		21		17		14		13		11		8.5		0.70 and Below		
Frame Size	Input KW HP	Output Torque kgf.m/min.lbs	Input KW HP	Output Torque kgf.m/min.lbs	Input KW HP	Output Torque kgf.m/min.lbs	Input KW HP	Output Torque kgf.m/min.lbs	Input KW HP	Output Torque kgf.m/min.lbs	Input KW HP	Output Torque kgf.m/min.lbs	Input KW HP	Output Torque kgf.m/min.lbs	Output Torque kgf.m/min.lbs	H	V
609	0.26 0.35	9.15 794	0.26 0.35	11.0 955	0.22 0.30	11.7 1016	0.19 0.25	12.0 1042	0.18 0.24	12.9 1120	0.15 0.20	13.0 1128	0.12 0.16	13.0 1128	13 1128	181	210
610	0.49 0.66	17.5 1519	0.49 0.66	21.1 1831	0.42 1.13	22.7 1970	0.37 0.50	24.0 2083	0.34 0.46	24.6 2135	0.30 0.40	26.0 2257	0.24 0.32	26.0 2257	26 2257	181	210
611	0.98 1.31	34.8 3021	0.98 1.31	41.9 3637	0.84 1.13	45.0 3906	0.72 0.96	46.5 4036	0.68 0.91	48.1 4175	0.59 0.79	50.6 4392	0.48 0.64	51.0 4427	51 4427	182	211
612	1.01 1.35	35.9 3116	1.02 1.37	43.6 3784	0.87 1.17	46.5 4036	0.76 1.02	49.0 4253	0.72 0.96	51.0 4427	0.60 0.80	51.0 4427	0.48 0.64	51.0 4427	51 4427	182	211
613	1.82 2.44	64.7 5616	1.80 2.41	76.8 6666	1.44 1.93	77.0 6684	1.20 1.61	77.0 6084	1.08 1.45	77.0 6684	0.90 1.21	77.0 6684	0.72 0.96	77.0 6684	77 6684	183	212
614	2.10 2.82	75.0 6510	2.11 2.83	90.2 7829	1.81 2.43	96.8 8402	1.58 2.12	101 8787	1.44 1.93	103 8940	1.20 1.61	103 8940	0.96 1.29	103 8940	103 8940	183	212
615	2.17 2.91	115 9982	2.17 2.91	148 12846.4	1.87 2.51	168 14582.4	1.59 2.13	168 14582.4	1.44 1.93	168 14582.4	1.20 1.61	168 14582.4	0.96 1.29	168 14582.4	168 14582.4	184	213
616	4.10 5.50	127 11023.6	4.09 5.48	154 13367.2	3.42 4.59	175 15190	2.85 3.92	175 15190	2.57 3.45	175 15190	2.14 2.87	175 15190	1.71 2.29	175 15190	175 15190	184	213
617	6.01 8.06	214 18575	6.01 8.06	257 22308	5.16 6.92	276 23957	4.34 5.82	278 24130	3.90 5.23	278 24130	3.25 4.36	278 24130	2.60 3.49	278 24130	278 24130	185	214
618	7.33 9.83	261 22655	7.35 9.86	314 27255	6.27 8.41	335 29078	5.54 7.43	355 30814	5.15 6.91	367 31856	4.55 6.10	389 33765	3.84 5.15	410 35588	410 35588	185	214
619	13.4 18.0	479 41577	13.4 18.0	573 49736	11.5 15.4	614 53295	10.1 13.5	648 56246	9.38 12.6	668 57982	8.29 11.1	709 615141	6.83 9.16	730 63364	730 63364	186	215

Ratio 87

Input Speed(R.P.M)	1800		1500		1200		1000		900		750		600		50 and Below	Dimension page	
Output Speed(R.P.M)	21		17		14		11		10		8.6		6.9		0.57 and Below		
Frame Size	Input KW HP	Output Torque kgf.m/min.lbs	Input KW HP	Output Torque kgf.m/min.lbs	Input KW HP	Output Torque kgf.m/min.lbs	Input KW HP	Output Torque kgf.m/min.lbs	Input KW HP	Output Torque kgf.m/min.lbs	Input KW HP	Output Torque kgf.m/min.lbs	Input KW HP	Output Torque kgf.m/min.lbs	Output Torque kgf.m/min.lbs	H	V
609	0.24 0.32	10.6 920	0.25 0.34	12.9 1120	0.20 0.27	13.0 1128	0.16 0.21	13.0 1128	0.15 0.20	13.0 1128	0.12 0.16	13.0 1128	0.10 0.13	13.0 1128	13 1128	181	210
610	0.49 0.66	21.5 1866	0.49 0.66	25.9 2248	0.40 0.54	26.0 2257	0.33 0.44	26.0 2257	0.30 0.40	26.0 2257	0.20 0.27	26.0 2257	0.20 0.27	26.0 2257	26 2257	181	210
611	0.93 1.25	40.5 3515	0.93 1.25	48.8 4236	0.78 1.05	51.0 4427	0.65 0.87	51.0 4427	0.58 0.78	51.0 4427	0.49 0.66	51.0 4427	0.39 0.52	51.0 4427	51 4427	182	211
612	0.93 1.25	40.8 3541	0.94 1.26	49.0 4253	0.78 1.05	51.0 4427	0.65 0.87	51.0 4427	0.58 0.78	51.0 4427	0.49 0.66	51.0 4427	0.39 0.52	51.0 4427	51 4427	182	211
613	1.47 1.97	64.0 5555	1.46 1.96	76.5 6640	1.18 1.58	77.0 6684	0.98 1.31	77.0 6684	0.88 1.18	103 8940	0.74 0.99	103 8940	0.59 0.79	77.0 6684	77 6684	183	212
614	1.96 2.63	85.5 7421	1.95 2.62	102 8854	1.57 2.10	103 8940	1.31 1.76	103 8940	1.18 1.58	103 8940	0.98 1.31	183 15884	0.79 1.06	103 6684	103 6684	183	212
615	1.99 2.67	148 12846.4	1.97 2.64	168 14582.4	1.57 2.10	168 14582.4	1.31 1.76	168 14582.4	1.18 1.58	168 14582.4	0.98 1.31	168 14582.4	1.04 1.88	168 14582.4	168 14582.4	184	213
616	3.34 4.48	157 13627.6	3.34 4.48	175 15190	2.80 3.75	175 15190	2.33 3.12	175 15190	2.10 2.82	175 15190	1.75 2.35	175 15190	2.12 2.84	175 15190	175 15190	184	213
617	4.83 6.48	211 18315	4.83 6.48	253 21960	4.14 5.55	271 23533	3.54 4.75	278 24130	3.18 4.26	410 35588	2.65 3.55	730 63364	3.13 4.20	278 24130	278 24130	185	214
618	7.35 9.86	321 27863	7.35 9.86	385 33418	6.26 8.39	410 35588	5.22 7.00	410 35588	4.70 6.30	720 12546	3.91 5.24	730 63340	5.58 7.48	410 35588	410 35588	185	214
619	11.7 15.7	511 44355	11.7 15.7	615 53382	10.1 13.5	661 57375	8.85 11.9	695 60326	8.26 11.1	730 63364	6.97 9.35	730 63364	5.58 7.48	730 63364	730 63364	186	215
620	13.6 18.2	596 51733	13.7 18.4	718 62322	11.1 14.9	729 63277	9.29 12.4	730 63364	8.26 11.1	730 63364	6.97 9.35	730 63340	7.29 9.78	730 63364	730 63364	186	215
621	18.3 24.5	798 69266	18.2 24.4	954 82807	14.6 19.6	954 82807	12.2 16.4	955 82894	109 14.6	955 82894	9.12 12.2	955 82894	9.74 13.1	955 82894	955 82894	187	216
622	21.9 29.4	957 83068	21.9 29.4	1148 99646	18.6 24.9	1222 106070	16.1 21.6	1267 109976	14.6 19.6	1275 110670	12.2 16.4	1275 110670	9.74 13.1	1275 110670	1275 110670	187	216
623					21.0 28.2	1377 119524	20.7 27.8	1625 141050	18.6 24.9	1625 141050	15.5 20.8	1625 141050	12.4 16.6	1625 141050	1625 141050	188	217

Input Speed(R.P.M)	1800		1500		1200		1000		900		750		600		50 and Below	Dimension page	
Output Speed(R.P.M)	21		17		14		11		10		8.6		6.9		0.57 and Below		
Frame Size	Input KW HP	Output Torque kgf.m/in.lbs	Input KW HP	Output Torque kgf.m/in.lbs	Input KW HP	Output Torque kgf.m/in.lbs	Input KW HP	Output Torque kgf.m/in.lbs	Input KW HP	Output Torque kgf.m/in.lbs	Input KW HP	Output Torque kgf.m/in.lbs	Input KW HP	Output Torque kgf.m/in.lbs	Output Torque kgf.m/in.lbs	H	V
624					26.7 35.8	1747 151640	25.1 35.0	2050 177940	23.5 31.5	2050 177940	23.5 31.5	2050 177940	23.5 31.5	2050 177940	2050 177940	188	217
625					34.2 45.9	2240 194432	33.7 45.2	2645 229586	30.4 40.8	2650 230020	30.4 40.8	2650 230020	30.4 40.8	2650 230020	2650 230020	189	218
626					45.7 61.3	2995 259966	45.2 60.6	3550 308140	40.7 54.6	3550 308140	40.7 54.6	3550 308140	40.7 54.6	3550 308140	3550 308140	189	218
627					51.2 68.7	3350 290780	51.2 68.7	4020 348936	49.5 66.4	4321 375063	49.5 66.4	4321 375063	49.5 66.4	4321 375063	6100 529480	190	219

Ratio	119
-------	-----

Input Speed(R.P.M)	1800		1500		1200		1000		900		750		600		50 and Below	Dimension page	
Output Speed(R.P.M)	15		13		10		8		7		6		5		0.42 and Below		
Frame Size	Input KW HP	Output Torque kgf.m/in.lbs	Input KW HP	Output Torque kgf.m/in.lbs	Input KW HP	Output Torque kgf.m/in.lbs	Input KW HP	Output Torque kgf.m/in.lbs	Input KW HP	Output Torque kgf.m/in.lbs	Input KW HP	Output Torque kgf.m/in.lbs	Input KW HP	Output Torque kgf.m/in.lbs	Output Torque kgf.m/in.lbs	H	V
609	0.11 0.15	6.40 556	0.10 0.13	7.10 616	0.08 0.11	7.10 616	0.08 0.11	7.10 616	0.07 0.09	7.10 616	0.06 0.08	7.10 616	0.04 0.05	7.10 616	7.1 616	181	210
610	0.24 0.32	14.5 1259	0.25 0.34	17.8 1545	0.21 0.28	17.8 1545	0.21 0.28	19.2 1666	0.19 0.25	20.5 1779	0.18 0.24	21.0 1823	0.12 0.16	21.0 1823	21 1823	181	210



# SELECTION TABLE FOR DOUBLE STAGE REDUCERS

(Allowable Transmission Input-Output Capacity)

Input at 1500 R.P.M.

Ratio	1 0 4 (13 x 8)		1 2 1 (11 x 11)		1 4 3 (13 x 11)		1 6 5 (15 x 11)		1 9 5 (15 x 13)		Dimension page		
	Output Speed(R.P.M.)	14	12	10	9.1	7.7	14	12	10	9.1		7.7	
Frame Size	Input kw/HP	Output Torque kgf.m/in.lbs	Input kw/HP	Output Torque kgf.m/in.lbs	Input kw/HP	Output Torque kgf.m/in.lbs	Input kw/HP	Output Torque kgf.m/in.lbs	Input kw/HP	Output Torque kgf.m/in.lbs	Input kw/HP	Output Torque kgf.m/in.lbs	
607/07			0.10 0.13	2.50/217	0.10 0.13	2.50/217	0.10 0.13	2.50/217	0.10 0.13	2.50/217	0.10 0.13	2.50/217	191
608/07			0.10 0.13	4.63/402	0.10 0.13	5.10/443	0.10 0.13	5.10/443	0.10 0.13	5.10/443	0.10 0.13	5.10/443	191
609/08	0.18 0.24	10.1/877	0.16 0.21	10.6/820	0.14 0.19	10.9/946	0.14 0.19	13.0/1128	0.12 0.16	13.0/1128	0.12 0.16	13.0/1128	192
610/08	0.36 0.48	20.5/1779	0.31 0.42	20.5/1779	0.26 0.35	20.5/1779	0.29 0.39	26.0/2257	0.24 0.32	26.0/2257	0.24 0.32	26.0/2257	192
611/08	0.40 0.54	22.5/1953	0.40 0.54	26.3/2283	0.40 0.54	31.5/2734	0.40 0.54	36.1/3133	0.40 0.54	42.9/3724	0.40 0.54	42.9/3724	193
611/09	0.84 1.13	48.0/4166	0.76 1.02	58.0/4340	0.65 0.87	51.0/4427	0.56 0.75	51.0/4427	0.48 0.64	51.0/4427	0.48 0.64	51.0/4427	193
613/08													194
613/09	1.35 1.81	77.0/6684	1.06 1.42	77.0/6684	0.98 1.31	77.0/6684	0.85 1.14	77.0/6684	0.72 0.96	77.0/6684	0.72 0.96	77.0/6684	194
613/10	1.35 1.81	77.0/6684	1.16 1.56	77.0/6684	0.98 1.31	77.0/6684	0.85 1.14	77.0/6684					195
614/08													195
614/09					1.04 1.39	81.0/7031	1.02 1.37	91.8/7968	0.86 1.15	92.2/8003	0.86 1.15	92.2/8003	196
614/10	1.81 2.43	103/8940	1.45 1.94	96.0/8333	1.32 1.77	10.3/8940	1.14 1.53	103/8940	0.97 1.30	103/8940	0.97 1.30	103/8940	196
616/09													197
616/10	2.42 3.24	160/13888	2.57 3.45	170/14756	2.34 3.14	183/15884	2.03 2.72	183/15884	1.72 2.31	183/15884	1.72 2.31	183/15884	197
616/11	3.22 4.32	183/15884	2.77 3.71	183/15884	2.34 3.14	183/15884							198
617/09													198
617/10							2.55 3.42	230/19964	2.41 3.23	257/22308	2.41 3.23	257/22308	199
617/11	4.89 6.56	278/24130	3.86 5.18	255/22134	3.56 4.77	278/24130	3.08 4.13	278/24130	2.61 3.50	278/24130	2.61 3.50	278/24130	199
618/10													200
618/13	7.04 9.44	400/34720	5.06 6.78	335/29078	5.13 6.88	401/34807	4.45 6.09	410/35588	3.85 5.16	410/35588	3.85 5.16	410/35588	200
619/11									4.78 6.41	510/44268	4.78 6.41	510/44268	201
619/13	10.0 13.4	570/49476	8.61 11.5	570/49476	7.80 10.5	610/52948	6.76 9.06	610/52948	6.10 8.18	650/56420	6.10 8.18	650/56420	201
620/11													202
620/13			8.69 11.6	575/49910			7.70 10.3	695/60326	6.52 8.74	695/60326	6.52 8.74	695/60326	202
621/13			9.98 13.4	660/57288			9.48 12.7	855/74214	8.02 10.8	855/74214	8.02 10.8	855/74214	203
621/16			11.1 14.9	735/63798			9.48 12.7	855/74214	8.02 10.8	855/74214	8.02 10.8	855/74214	203
622/13									9.19 12.3	980/85064	9.19 12.3	980/85064	204
622/17			14.5 19.4	960/83328			12.2 16.4	1100/95480	10.3 13.8	1100/95480	10.3 13.8	1100/95480	204
623/16			16.9 22.7	1120/97216			15.5 20.8	1400/121520	13.1 17.6	1410/122100	13.1 17.6	1410/122100	205
623/18			16.9 22.7	1120/97216			15.5 20.8	1400/121520	13.1 17.6	1410/122100	13.1 17.6	1410/122100	205
624/16							18.1 24.3	1630/141484	17.0 22.8	1810/157108	17.0 22.8	1810/157108	206
624/18			21.3 28.6	1410/122388			20.1 27.0	1810/157008	17.0 22.8	1810/157108	17.0 22.8	1810/157108	206
625/17			27.1 36.3	1790/155372			25.5 34.2	2300/199640	21.6 29.0	2300/199640	21.6 29.0	2300/199640	207
625/19			27.2 36.5	1800/156240			25.5 34.2	2300/199940					207
626/19			36.3 48.7	2400/208320			33.8 45.3	3050/264740	28.6 38.4	3050/264740	28.6 38.4	3050/264740	208



Ratio	231 (21x11)		273 (21x13)		319 (29x11)		377 (29x13)		473 (43x11)		Dimension page
	6.5		5.5		4.7		4.0		3.2		
Output Speed(R.P.M.)	Input kw/HP	Output Torque kgf.m/in.lbs	Input kw/HP	Output Torque kgf.m/in.lbs	Input kw/HP	Output Torque kgf.m/in.lbs	Input kw/HP	Output Torque kgf.m/in.lbs	Input kw/HP	Output Torque kgf.m/in.lbs	
607/07	0.10 0.13	2.50/217	0.10 0.13	2.50/217	0.10 0.13	2.50/217	0.10 0.13	2.50/217	0.10 0.13	2.50/217	191
608/07	0.10 0.13	5.10/443	0.10 0.13	5.10/443	0.10 0.13	5.10/443	0.10 0.13	5.10/443	0.10 0.13	5.10/443	191
609/08	0.10 0.13	13.0/1128	0.10 0.13	13.0/1128	0.10 0.13	13.0/1128	0.10 0.13	13.0/1128	0.10 0.13	13.0/1128	192
610/08	0.20 0.27	26.0/2257	0.17 0.23	26.0/2257	0.15 0.20	26.0/2257	0.13 0.17	26.0/2257	0.10 0.13	26.0/2257	192
611/08	0.40 0.54	51.0/4427	0.34 0.46	51.0/4427	0.29 0.39	51.0/4427	0.25 0.34	51.0/4427	0.20 0.27	51.0/4427	193
611/09	0.40 0.54	51.0/4427	0.34 0.46	51.0/4427							193
613/08							0.37 0.50	77.0/6684	0.30 0.40	77.0/6684	194
613/09	0.61 0.82	77.0/6684	0.52 0.70	77.0/6684	0.44 0.59	77.0/6684	0.37 0.50	77.0/6684			194
613/10											195
614/08									0.40 0.54	103/8940	195
614/09	0.82 1.10	103/8940	0.69 0.92	103/8940	0.59 0.79	103/8940	0.50 0.67	103/3940	0.40 0.54	103/8940	196
614/10	0.82 1.10	103/8940	0.69 0.92	103/8940							196
616/09	1.15 1.54	145/12586	1.07 1.43	160/13888	1.05 1.41	183/15884	0.89 1.19	183/15884	0.71 0.95	183/15884	197
616/10	1.45 1.94	183/15884	1.23 1.65	183/15884	1.05 1.41	183/15884	0.89 1.19	183/15884			197
616/11											198
617/09									1.08 1.45	278/24130	198
617/10	2.20 2.95	278/24130	1.86 2.49	278/24130	1.59 2.13	278/24130	1.35 1.81	278/24130	1.08 1.45	278/24130	199
617/11	2.20 2.95	278/24130			2.13 2.86	278/24130					199
618/10	2.49 3.34	315/27342	2.70 3.62	403/34980	2.35 3.15	410/35588	1.99 2.67	410/35588	1.58 2.12	410/35588	200
618/13	3.25 4.36	410/35588	2.75 3.69	410/35588	2.35 3.15	410/35588	1.99 2.67	410/35588			200
619/11	4.43 5.94	560/48608	3.89 5.22	580/50344	3.56 4.77	620/53816	2.81 3.77	580/50344	2.28 3.06	590/51212	201
619/13	5.78 7.75	730/63364	4.89 6.66	730/63364	4.19 5.62	703/63364	3.54 4.75	730/63364	2.82 3.78	730/63364	201
620/11											202
620/13	5.78 7.75	730/83364			4.19 5.62	730/83364			3.31 4.44	855/74214	202
621/13	7.64 10.2	965/83762	6.47 8.68	965/83762	5.53 7.42	965/83762	4.68 6.28	965/83762	4.37 5.86	1130/98084	203
621/16	7.64 10.2	965/83762			5.53 7.42	965/83762			4.37 5.86	1130/98084	203
622/13	9.90 13.3	1250/108500	8.54 11.4	1275/110670	7.31 9.80	1275/110670	6.19 8.30	1275/110670	5.57 7.47	1440/124992	204
622/17	10.1 13.5	1275/110670	8.54 11.4	1275/110670	7.31 9.80	1275/110675	6.19 8.3	1275/110670			204
623/16	12.6 16.9	1590/138012	10.8 14.5	1620/140616	9.00 12.1	1570/136276	7.86 10.5	1620/140616	7.06 9.47	1825/158420	205
623/18											205
624/16	16.0 21.4	2020/175336	13.7 18.4	205C/177940	11.5 15.4	2000/173600	9.95 13.3	2050/177940	9.09 12.2	2350/203980	206
624/18	16.2 21.7	2050/177940	13.7 18.4	2050/177940	11.6 15.6	2030/176204	9.95 13.3	2050/177940	9.09 12.2	2350/203980	206
625/17	21.0 28.2	2650/230020	17.8 23.9	2650/230020	15.2 20.4	2650/230020	12.8 17.2	2650/230020	11.8 15.8	3050/264740	207
625/19	21.0 28.2	2650/230020									207
626/19	27.4 36.7	3460/300328	23.4 31.4	3500/303800	20.1 27.0	3500/303800	17.0 22.8	3500/303800	16.0 21.4	4140/359352	208
627/19					33.8 45.3	5900/512120	29.8 40.0	6150/533820	23.8 31.9	6150/533820	208

\* Please avoid use at the full input capacity and use within the allowable output torque for frame sizes shown in the   column.

\* Please refer to the Allowable Overhung Load for each frame size as shown on page 225.

Ratio	5 5 9 (4 3 x 1 3)		6 4 9 (5 9 x 1 1)		7 3 1 (4 3 x 1 7)		8 4 1 (2 9 x 2 9)		1 0 0 3 (5 9 x 1 7)		Dimension page
Output Speed(R.P.M.)	2.7		2.3		2.1		18		1.5		
Frame Size	Input kw/HP	Output Torque kgf.m/in.lbs	Input kw/HP	Output Torque kgf.m/in.lbs	Input kw/HP	Output Torque kgf.m/in.lbs	Input kw/HP	Output Torque kgf.m/in.lbs	Input kw/HP	Output Torque kgf.m/in.lbs	
607/07	0.10 0.13	2.50/217		2.50/217	0.10 0.13	2.50/217	0.10 0.13	2.50/217	0.10 0.13	2.50/217	191
608/07	0.10 0.13	5.10/443	0.10 0.13	5.10/443	0.10 0.13	5.10/443	0.10 0.13	5.10/443	0.10 0.13	5.10/443	191
609/08	0.10 0.13	13.0/1128	0.10 0.13	13.0/1128	0.10 0.13	13.0/1128	0.10 0.13	13.0/1128	0.10 0.13	13.0/1128	192
610/08	0.10 0.13	26.0/2257	0.10 0.13	26.0/2257	0.15 0.20	26.0/2257	0.10 0.13	26.0/2257	0.10 0.13	26.0/2257	192
611/08	0.17 0.23	51.0/4427	0.14 0.19	51.0/4427	0.29 0.39	51.0/4427	0.11 0.15	51.0/4427	0.20 0.27	51.0/4427	193
611/09											193
613/08	0.25 0.34	77.0/6684	0.22 0.30	77.0/6684	0.20 0.27	77.0/6684	0.20 0.27	77.0/6684	0.20 0.27	77.0/6684	194
613/09											194
613/10											195
614/08	0.34 0.46	103/8940	0.29 0.39	103/8940	0.26 0.35	103/8940	0.22 0.30	103/8940	0.20 0.27	103/8940	195
614/09	0.34 0.46	103/8940					0.22 0.30	103/8940			196
614/10											196
616/09	0.60 0.80	183/15884	0.52 0.70	183/15884	0.46 0.62	183/15884	0.40 0.54	183/15884	0.40 0.54	183/15884	197
616/10											197
616/11											198
617/09	0.91 1.22	278/24130	0.78 1.05	278/24130	0.70 0.94	278/24130	0.60 0.80	278/24130	0.51 0.68	278/24130	198
617/10	0.91 1.22	278/24130	0.78 1.05	278/24130			0.60 0.80	278/24130			199
617/11											199
618/10	1.34 1.80	410/35588	1.16 1.56	410/35588	1.02 1.37	410/35588	0.89 1.19	410/45588	0.75 1.00	410/35588	200
618/13			1.16 1.56	410/35588							200
619/11	2.00 2.68	610/52948	1.78 2.39	630/34684	1.70 2.28	680/59024	1.59 2.13	730/63364	1.31 1.76	720/62496	201
619/13	2.39 3.20	730/63364	2.06 2.76	730/63364	1.83 2.45	730/63364	1.59 2.13	730/63364	1.33 1.78	730/63364	201
620/11											202
620/13	2.80 3.75	855/74214	2.41 3.23	855/74214	2.20 2.95	855/74214			2.20 2.95	840/72912	202
621/13	3.70 4.96	1130/98084	3.18 4.26	1130/98084	2.83 3.80	1130/98084	2.20 0.95	978/84890	2.20 2.95	1130/98084	203
621/16											203
622/13	4.71 6.32	1440/124992	4.06 5.44	1440/124992	3.60 4.82	1440/124992	2.72 3.65	1250/158500	2.63 3.53	1440/124992	204
622/17											204
623/16	5.97 8.01	1825/158410	5.14 6.89	1825/158410	4.57 6.13	1825/158410	3.57 4.79	1640/142352	3.33 4.46	1825/158410	205
623/18											205
624/16	7.69 1.03	2350/203980	6.62 8.88	2350/203980	5.88 7.88	2350/203980	4.46 5.98	2050/177940	4.28 5.74	2350/203980	206
624/18			6.62 8.88	2350/203980							206
625/17	9.98 13.4	3050/264740	8.50 11.5	3050/264740	7.63 10.2	3050/264740	5.86 7.86	2695/233926	5.56 7.46	3050/264740	207
625/19											207
626/19	13.5 18.1	4140/359352	11.7 15.7	4140/359352	10.4 13.9	4140/359352	7.70 10.3	3540/307272	7.55 10.1	4140/359352	208
627/19	20.1 27.0	6150/533820	17.3 23.2	6150/533820	15.4 20.6	6150/533820	13.4 18.0	6150/533820	11.2 15.0	6150/533820	208

\* Please avoid use at the full input capacity and use within the allowable output torque for frame sizes shown in the  column.

\* Please refer to the Allowable Overhung Load for each frame size as shown on page 225.



Ratio	1 2 4 7 (4 3 x 2 9)		1 4 7 9 (8 7 x 1 7)		1 8 4 9 (4 3 x 4 3)		2 0 6 5 (5 9 x 3 5)		2 5 3 7 (5 9 x 4 3)		Dimension page
	Output Speed(R.P.M.)	1.2	1.0	1.0	0.81	0.73	0.59	0.59	0.59		
Frame Size	Input kw/HP	Output Torque kgf.m/in.lbs	Input kw/HP	Output Torque kgf.m/in.lbs	Input kw/HP	Output Torque kgf.m/in.lbs	Input kw/HP	Output Torque kgf.m/in.lbs	Input kw/HP	Output Torque kgf.m/in.lbs	
607/07	0.10 0.13	2.50/217			0.10 0.13	2.50/217					191
608/07	0.10 0.13	5.10/443			0.10 0.13	5.10/443	0.10 0.13	5.10/443	0.10 0.13	5.10/443	191
609/08	0.10 0.13	13.0/1128	0.10 0.13	13.0/1128	0.10 0.13	13.0/2257	0.10 0.13	13.0/1128	0.10 0.13	13.0/1128	192
610/08	0.10 0.13	26.0/2257	0.10 0.13	26.0/2257	0.10 0.13	26.0/2257	0.10 0.13	26.0/2257	0.10 0.13	26.0/2257	192
611/08	0.10 0.13	51.0/4427	0.10 0.13	51.0/4427	0.10 0.13	51.0/4427	0.10 0.13	51.0/4427	0.10 0.13	51.0/4427	193
611/09											193
613/08	0.20 0.27	77.0/6684	0.20 0.27	77.0/6684	0.20 0.27	77.0/6684	0.20 0.27	77.0/6684	0.20 0.27	77.0/6684	194
613/09											194
613/10											195
614/08	0.20 0.27	103/8940	0.20 0.27	103/8940	0.20 0.27	103/8940	0.20 0.27	130/8940	0.20 0.27	103/8940	195
614/09											196
614/10											196
616/09	0.40 0.54	183/15884	0.40 0.54	183/15884	0.20 0.27	183/15884	0.20 0.27	183/15884	0.20 0.27	183/15884	197
616/10											197
616/11											198
617/09	0.40 0.54	278/24130	0.40 0.54	278/24130	0.40 0.54	278/24130	0.40 0.54	278/24130	0.20 0.27	278/24130	198
617/10											199
617/11											199
618/10	0.75 1.00	410/35588	0.75 1.00	410/35588	0.75 1.00	410/35588	0.40 0.54	410/35588	0.40 0.54	410/35588	200
618/13											200
619/11	1.07 1.43	730/63364	0.90 1.21	730/63364	0.75 1.00	730/63364	0.75 1.00	730/63364	0.75 1.00	730/63364	201
619/13			0.90 1.21	730/63364							201
620/11					1.50 2.01	810/70308	1.50 2.01	810/70308	0.75 1.00	810/70308	202
620/13	1.50 2.01	840/72912			1.50 2.01	840/72912	1.50 2.01	840/72912	0.75 1.00	840/72912	202
621/13	2.20 2.95	1130/98084	1.50 2.01	1130/98084	1.50 2.01	1140/98952	1.50 2.01	1140/98952	1.50 2.01	1140/98952	203
621/16											203
622/13	2.20 2.95	1420/123256	2.20 2.95	1420/12356	1.50 2.01	1440/124992	1.50 2.01	1440/124992	1.50 2.01	1440/124992	204
622/17											204
623/16	2.68 3.59	1825/158410	2.20 2.95	1640/142352	2.20 2.95	1825/158410	2.20 2.95	1825/158410	2.20 2.95	1825/158410	205
623/18											205
624/16	3.45 4.63	2350/203980	2.56 3.43	2070/179676	2.32 3.11	2350/203980	2.20 2.95	2350/203980	2.20 2.95	2350/203980	206
624/18											206
625/17	4.47 5.99	3050/264740	3.70 4.96	2695/233926	3.70 4.96	3050/264740	3.70 4.96	3050/264740	3.70 4.96	3050/264740	207
625/19											207
626/19	6.07 8.14	4140/359352	5.50 7.38	3650/316820	5.50 7.38	4140/359352	5.50 7.38	4140/359352	5.50 7.38	4100/359352	208
627/19	11.0 14.8	6150/533820	11.0 14.8	6150/533820	7.50 10.0	6150/533820	7.50 10.0	6150/533820	7.50 10.0	6150/533820	208

\* Please avoid use at the full input capacity and use within the allowable output torque for frame sizes shown in the   column.

\* Please refer to the Allowable Overhung Load for each frame size as shown on page 225.



Ratio	3045 (87x35)		3481 (59x59)		4437 (87x51)		5133 (87x59)		6177 (87x71)		7569 (87x87)		Dimension page
Output Speed(R.P.M.)	0.49		0.43		0.34		0.29		0.24		0.20		
Frame Size	Input kw/HP	Output Torque kgf.m/in.lbs	Input kw/HP	Output Torque kgf.m/in.lbs	Input kw/HP	Output Torque kgf.m/in.lbs	Input kw/HP	Output Torque kg.m/in.lb	Input kw/HP	Output Torque kgf.m/in.lbs	Input kw/HP	Output Torque kgf.m/in.lbs	
607/07													191
608/07													191
609/08	0.10 0.13	13.0/1128	0.10 0.13	13.0/1128	0.10 0.13	13.0/1128	0.10 0.13	13.0/1128					192
610/08	0.10 0.13	26.0/2257	0.10 0.13	26.0/2257	0.10 0.13	26.0/2257	0.10 0.13	26.0/2257					192
611/08	0.10 0.13	51.0/4427	0.10 0.13	51.0/4427	0.10 0.13	51.0/4427	0.10 0.13	51.0/4427					193
611/09									0.10 0.13	51.0/4427	0.10 0.13	51.0/4427	193
6213/08	0.20 0.27	77.0/6684	0.20 0.27	77.0/6684	0.20 0.27	77.0/6684	0.20 0.27	77.0/6684					194
613/09									0.20 0.27	77.0/6684	0.20 0.27	77.0/8884	194
613/10													195
614/08	0.20 0.27	103/8940	0.20 0.27	103/8940	0.20 0.27	103/8940	0.20 0.27	103/8940					195
614/09									0.20 0.27	103.8940	0.20 0.27	103/8940	196
614/10													196
616/09	0.20 0.27	183/15884	0.20 0.27	183/15834	0.20 0.27	183/15884	0.20 0.27	183/15884	0.20 0.27	183/15884	0.20 0.27	83/15884	197
616/10													197
616/11													198
617/09	0.20 0.27	278/24130	0.20 0.27	278/24130	0.20 0.27	278/24130	0.20 0.27	278/24130	0.20 0.27	278/24130	0.20 0.27	278/24130	198
617/10													199
617/11													199
618/10	0.40 0.54	410/35588	0.40 0.54	410/35588	0.40 0.54	410/35588	0.40 0.54	410/35588	0.40 0.54	410/35588	0.40 0.54	410/35588	200
618/13													200
619/11	0.75 1.00	730/63364	0.75 1.00	730/63364	0.75 1.00	730/63364	0.75 1.00	730/63364	0.75 1.00	730/63364	0.75 1.00	730/63364	201
619/13													201
620/11			0.75 1.00	860/74648			0.75 1.00	860/74648					202
620/13													202
621/13	1.50 2.01	955/82894	1.50 2.01	1140/98952	1.50 2.01	950/82460	1.50 2.01	1140/98952	1.50 2.01	850/82460	1.50 2.01	950/82460	203
621/16													203
622/13	1.50 2.01	1250/108500	1.50 2.01	1440/124992	1.50 2.01	1275/110670	1.50 2.01	1440/124992	1.50 2.01	1275/100670	1.50 2.01	1275/110670	204
622/17													204
623/16	2.20 2.95	1620/140616	2.20 2.95	1810/157108	2.20 2.95	1600/138880	2.20 2.95	1810/157108	2.20 2.95	1600/138880	2.20 2.95	1600/138880	205
623/18													205
624/16	2.20 2.95	2050/177940	2.20 2.95	2350/203980	2.20 2.95	2050/177940	2.20 2.95	2350/203980	2.20 2.95	2050/177940	2.20 2.95	2050/177940	206
624/18													206
625/17	3.70 4.96	2850/227700	3.70 4.96	3050/264740	3.70 4.96	2650/230020	3.70 4.96	3050/264740	3.70 4.96	2650/230020	3.70 4.96	2650/230020	207
625/19													207
626/19	5.50 7.38	3540/307272	5.50 7.38	4100/355880	5.50 7.38	3520/305536	5.50 7.38	4100/355880	5.50 7.38	3520/305536	5.50 7.38	3520/305536	208
627/19	7.50 10.0	6150/533820	7.50 10.0	6150/533820	7.50 10.0	6150/533820	7.50 10.0	6150/533820	7.50 10.0	6150/533820	7.50 10.0	6150/533820	208

\* Please avoid use at the full input capacity and use within the allowable output torque for frame sizes shown in the   column.

\* Please refer to the Allowable Overhung Load for each frame size as shown on page 225.

# SELECTION TABLE FOR DOUBLE STAGE REDUCERS

(Allowable Transmission Input-Output Capacity)

Input at 1800 R.P.M.

Ratio	104 (13x8)		121 (11x11)		143 (13x11)		165 (15x11)		195 (15x13)		Dimension page		
	Output Speed(R.P.M.)	17	15	13	11	9.2	17	15	13	11		9.2	
Frame Size	Input kw/HP	Output Torque kgf.m/in.lbs	Input kw/HP	Output Torque kgf.m/in.lbs	Input kw/HP	Output Torque kgf.m/in.lbs	Input kw/HP	Output Torque kgf.m/in.lbs	Input kw/HP	Output Torque kgf.m/in.lbs	Input kw/HP	Output Torque kgf.m/in.lbs	
607/07			0.10 0.13	2.50/217	0.10 0.13	2.50/217	0.10 0.13	2.50/217	0.10 0.13	2.50/217	0.10 0.13	2.50/217	191
608/07			0.10 0.13	4.40/382	0.10 0.13	4.95/430	0.10 0.13	5.10/443	0.10 0.13	5.10/443	0.10 0.13	5.10/443	191
609/08	0.21 0.28	10.1/877	0.18 0.24	10.2/885	0.17 0.23	11.2/972	0.17 0.23	12.7/1102	0.15 0.20	13.0/1128	0.15 0.20	13.0/1128	192
610/08	0.41 0.55	19.4/1684	0.38 0.51	21.1/1831	0.34 0.46	22./1910	0.34 0.46	26.0/2257	0.29 0.39	26.0/2257	0.29 0.39	26.0/2257	192
611/08	0.40 0.54	19.1/1658	0.40 0.54	22.0/1909	0.40 0.54	26.1/2265	0.40 0.54	30.5/2647	0.40 0.54	36.0/3125	0.40 0.54	36.0/3125	193
611/09	0.97 1.30	45.8/3975	0.85 1.14	46.9/4071	0.77 1.03	50.0/4340	0.68 0.91	51.0/4427	0.57 0.76	51.0/4427	0.57 0.76	51.0/4427	193
613/08													194
613/09	13.6 1.84	65.0/5642	1.22 1.64	67.0/5819	1.18 1.58	77.0/6684	1.02 1.37	77.0/6684	0.87 1.17	77.0/6684	0.87 1.17	77.0/6684	194
613/10	1.62 2.17	77.0/6684	1.40 1.88	77.0/6684	1.18 1.58	77.0/6684	1.02 1.37	77.0/6684					195
614/08													195
614/09					1.23 1.63	80.0/6944	1.21 1.62	91.0/7899	1.03 1.38	91.6/7951	1.03 1.38	91.6/7951	196
614/10	2.15 2.88	102/854	1.74 2.33	96.2/8350	1.56 2.09	102/8854	1.37 1.84	103/89440	1.16 1.56	103/8940	1.16 1.56	103/8940	196
616/09													197
616/10	3.38 4.53	160/13888	3.08 4.13	170/1475	2.76 3.70	180/15624	2.42 3.24	182/15798	2.06 2.76	183/15884	2.06 2.76	183/15884	197
616/11	3.84 5.15	182/15798	3.30 4.42	182/15798	2.79 3.74	182/15798							198
617/09													198
617/10								3.06 4.10	230/19964	2.69 3.61	239/20745	2.69 3.61	199
617/11	5.09 6.82	241/20919	4.64 6.22	256/22221	4.23 5.67	276/23957	3.50 4.69	263/22828	3.11 4.17	276/23957	3.11 4.17	276/23957	199
618/10													200
618/13	8.49 11.4	402/34894	6.11 8.19	337/29252	6.14 8.23	400/34720	5.45 7.31	410/35588	5.62 6.20	410/35588	5.62 6.20	410/35588	200
619/11									5.63 7.55	500/43400	5.63 7.55	500/43400	201
619/13	10.6 14.2	500/43400	9.61 12.9	530/46004	8.75 11.7	570/49476	7.60 10.2	571/49563	6.87 9.21	610/52948	6.87 9.21	610/52948	201
620/11													202
620/13			9.87 13.2	544/47219			8.91 11.9	6.70/58156	7.82 10.5	695/60326	7.82 10.5	695/60326	202
621/13			9.89 13.2	545/47306			9.91 13.3	745/64666	9.46 12.7	840/72912	9.46 12.7	840/72912	203
621/16			12.9 17.3	711/61715			11.3 15.2	850/73780	9.57 12.8	850/73780	9.57 12.8	850/73780	203
622/13									9.79 13.1	870/75516	9.79 13.1	870/75516	204
622/17			16.5 22.1	910/78988			14.6 19.6	1100/95480	12.6 16.9	1120/99216	12.6 16.9	1120/99216	204
623/16			18.3 24.5	1010/87668			18.1 24.3	1360/118048	15.9 21.3	1410/122388	15.9 21.3	1410/122388	205
623/18			20.1 27.0	1110/96348			18.1 24.3	1360/118048	15.8 21.2	1400/121520	15.8 21.2	1400/121520	205
624/16							18.2 24.4	1365/118482	17.4 23.3	1550/134540	17.4 23.3	1550/134540	206
624/18			25.6 34.3	1410/122388			24.1 32.3	1810/157108	20.4 27.3	1810/157108	20.4 27.3	1810/157108	206
625/17			27.4 36.7	1510/122388			27.3 36.6	2052/178114	26.4 35.4	2345/203546	26.4 35.4	2345/203546	207
625/19			33.0 44.2	1820/*157976			32.0 42.9	2405/208754					207
626/19			42.9 57.5	2365/205282			39.0 52.3	2931/254411	34.7 46.5	3082/267518	34.7 46.5	3082/267518	208

\* Please avoid use at the full input capacity and use within the allowable output torque for frame sizes shown in the  column.

\* Please refer to the Allowable Overhung Load for each frame size as shown on page 225.



Ratio	231 (21x11)		273 (21x13)		319 (29x11)		377 (29x13)		473 (43x11)		Dimension page	
	Output Speed(R.P.M.)	7.8	6.6	5.6	4.8	3.8	7.8	6.6	5.6	4.8		3.8
Frame Size	Input kw/HP	Output Torque kgf.m/in.lbs	Input kw/HP	Output Torque kgf.m/in.lbs	Input kw/HP	Output Torque kgf.m/in.lbs	Input kw/HP	Output Torque kgf.m/in.lbs	Input kw/HP	Output Torque kgf.m/in.lbs	Input kw/HP	Output Torque kgf.m/in.lbs
607/07	0.10 0.13	2.50/217	0.10 0.13	2.50/217	0.10 0.13	2.50/217	0.10 0.13	2.50/217	0.10 0.13	2.50/217		191
608/07	0.10 0.13	5.10/443	0.10 0.13	5.10/443	0.10 0.13	5.10/443	0.10 0.13	5.10/443	0.10 0.13	5.10/443		191
609/08	0.12 0.16	13.0/1128	0.10 0.13	13.0/1128	0.10 0.13	13.0/1128	0.10 0.13	13.0/1128	0.10 0.13	13.0/1128		192
610/08	0.25 0.34	26.0/2257	0.21 0.28	26.0/2257	0.18 0.24	26.0/2257	0.15 0.20	26.0/2257	0.12 0.16	26.0/2257		192
611/08	0.40 0.54	42.2/3663	0.40 0.54	50.5/4383	0.35 0.47	51.0/4427	0.30 0.40	51.0/4427	0.24 0.32	51.0/4427		193
611/09	0.48 0.64	51.0/4427	0.41 0.55	51.0/4427								193
613/08							0.40 0.54	69.5/6033	0.36 0.48	77.0/6684		194
613/09	0.73 0.98	77.0/6684	0.62 0.83	77.0/6684	0.53 0.71	77.0/6684	0.45 0.60	77.0/6684				194
613/10												195
614/08									0.41 0.55	87.5/7595		195
614/09	0.97 1.30	102/8854	0.83 1.10	103/8940	0.71 0.95	103/8940	0.60 0.80	103/8940	0.48 0.64	103/8940		196
614/10	0.98 1.31	103/8940	0.82 1.11	103/8940								196
616/09	1.33 1.78	140/12152	1.25 1.68	155/13454	1.24 1.66	180/15624	1.06 1.42	183/15884	0.85 1.14	183/15884		197
616/10	1.74 2.32	183/15884	1.47 1.97	183/15884	1.26 1.69	183/15884	1.06 1.42	183/15884				197
616/11												198
617/09									1.19 1.60	256/22221		198
617/10	2.64 3.54	278/24130	2.24 3.00	278/24130	1.85 2.48	269/3349	1.62 2.17	278/24130	1.28 1.72	277/24044		199
617/11	2.64 3.54	278/24130			1.91 2.56	278/24130						199
618/10	2.80 3.75	295/25606	2.67 3.58	332/28818	2.63 3.53	382/33158	2.35 3.15	404/35067	1.90 2.55	410/35588		200
618/13	3.90 5.23	410/35588	3.30 4.42	410/35588	2.82 3.78	410/35588	2.39 3.20	410/35588				200
619/11	4.99 6.69	525/45570	4.34 5.82	540/46872	3.72 4.99	540/46872			2.88 3.86	620/53816		201
619/13	6.79 9.10	715/62062	5.88 7.88	731/63451	4.84 6.49	703/61020	4.25 5.70	730/63364	3.39 4.55	730/63364		201
620/11												202
620/13	6.94 9.31	730/63364			5.00 6.70	727/63104			3.95 5.30	851/73867		202
621/13	9.16 12.3	964/83675	7.79 10.4	969/84109	6.64 8.90	965/83762	5.66 7.59	972/84370	5.24 7.03	1130/98084		203
621/16	9.20 12.3	968/84022			6.64 8.90	965/83762			5.29 7.09	1140/98952		203
622/13	9.93 13.3	1045/90706	9.40 12.6	1169/101469	8.51 11.4	1237/107372	7.46 10.0	1281/111191	6.63 8.89	1429/124037		204
622/17	11.9 16.0	1250/108500	10.2 13.7	1268/110062	8.52 11.4	1238/107458	7.28 9.76	1250/108500				204
623/16	14.4 19.3	1520/131936	12.7 17.0	1580/137144	10.4 13.9	1511/131155	9.10 12.2	1563/135668	8.16 10.9	1758/152594		205
623/18												205
624/16	18.2 24.4	1920/166656	16.2 21.7	2020/175336	13.1 17.6	1910/165788	11.6 15.6	2000/173600	10.7 14.3	2310/200508		206
624/18	19.0 25.5	2000/173600	16.4 22.0	2040/177072	13.6 18.2	1970/170996	11.6 15.6	2000/173600	10.8 14.5	2320/201376		206
625/17	25.5 33.8	2650/230020	16.4 22.0	2650/230020	18.2 24.4	2650/230020	15.4 20.6	2650/230020	14.2 19.0	3050/264740		207
625/19	25.2 33.8	2650/230020										207
626/19	31.4 42.1	3304/286787	27.9 37.4	3470/301196	23.0 30.8	3342/290086	20.4 27.3	3500/303800	18.4 24.9	4000/347200		208
627/19					37.9 50.8	5510/478268	33.8 45.3	5800/503440	26.7 35.8	5753/499360		208

\* Please avoid use at the full input capacity and use within the allowable output torque for frame sizes shown in the   column.

\* Please refer to the Allowable Overhung Load for each frame size as shown on page 225.



Ratio	559 (43x13)		649 (59x11)		731 (43x17)		841 (29x29)		1003 (59x17)		Dimension page
Output Speed(R.P.M.)	3.2		2.8		2.5		2.1		1.8		
Frame Size	Input kw/HP	Output Torque kgf.m/in.lbs	Input kw/HP	Output Torque kgf.m/in.lbs	Input kw/HP	Output Torque kgf.m/in.lbs	Input kw/HP	Output Torque kgf.m/in.lbs	Input kw/HP	Output Torque kgf.m/in.lbs	
607/07	0.10 0.13	2.50/217			0.10 0.13	2.50/217	0.10 0.13	2.50/217			191
608/07	0.10 0.13	5.10/443	0.10 0.13	5.10/443	0.10 0.13	5.10/443	0.10 0.13	5.10/443	0.10 0.13	5.10/443	191
609/08	0.10 0.13	13.0/1128	0.10 0.13	13.0/1128	0.10 0.13	13.0/1128	0.10 0.13	13.0/1128	0.10 0.13	13.0/1128	192
610/08	0.10 0.13	26.0/2257	0.10 0.13	26.0/2257	0.10 0.13	26.0/2257	0.10 0.13	26.0/2257	0.10 0.13	26.0/2257	192
611/08	0.20 0.27	51.0/4427	0.17 0.23	51.0/4427	0.15 0.20	51.0/4427	0.13 0.17	51.0/4427	0.11 0.15	51.0/4427	193
611/09											193
613/08	0.30 0.40	77.0/6684	0.26 0.35	77.0/6684	0.23 0.31	77.0/6684	0.20 0.27	77.0/6684	0.20 0.27	77.0/6684	194
613/09											194
613/10											195
614/08	0.40 0.54	102/8854	0.35 0.47	103/8940	0.31 0.42	102/8854	0.25 0.34	95.8/8315	0.22 0.30	103/8940	195
614/09	0.40 0.54	103/8940					0.27 0.36	103/8940			196
614/10											196
616/09	0.72 0.96	183/15884	0.62 0.83	183/15884	0.55 0.74	183/15884	0.48 0.64	103/15884	0.40 0.54	183/15884	197
616/10											197
616/11											198
617/09	1.06 1.42	270/23436	0.90 1.21	266/23890	0.83 1.11	276/23957	0.69 0.92	264/22915	0.61 0.82	278/24130	198
617/10	1.09 1.46	277/24044	0.93 1.25	276/23957			0.72 0.97	277/24044			199
617/11											199
618/10	1.61 2.16	410/35588	1.38 1.85	408/35414	1.23 1.65	410/35588	1.07 1.43	410/35588	0.90 1.21	410/35588	200
618/13			1.39 1.86	410/35588							200
619/11	2.34 3.14	595/51646	2.06 2.76	610/52948	1.89 2.53	631/54771	1.89 2.53	725/62930	1.43 1.92	653/56680	201
619/13	2.87 3.85	730/63364	2.47 3.31	730/63364	2.19 2.94	730/63364	1.90 2.55	730/63364	1.60 2.14	730/63364	201
620/11											202
620/13	3.30 4.42	840/72912	2.84 3.81	840/72912	2.52 3.38	840/72912			2.20 2.95	840/78912	202
621/13	4.44 5.95	1130/98084	3.83 5.14	1132/98258	3.39 4.55	1136/98587	2.50 3.35	958/83154	2.49 3.34	1140/98952	203
621/16											203
622/13	5.62 7.54	1430/124124	4.84 6.49	1430/124124	4.32 5.79	1440/124992	3.51 4.71	1345/116746	3.15 4.22	1440/124992	204
622/17											204
623/16	7.17 9.62	1820/157976	6.00 8.11	1774/153983	5.46 7.32	1820/157976	4.24 5.69	1624/140963	3.98 5.34	1820/157976	205
623/18											205
624/16	9.31 12.5	2371/205803	7.78 10.4	2300/199640	7.11 9.53	2368/205542	5.48 7.35	2100/182280	5.14 6.89	2350/203980	206
624/18			7.80 10.5	2306/200161							206
625/17	11.9 16.0	3030/263004	10.3 13.8	3050/264740	9.16 12.3	3050/264740	7.02 9.41	2690/233492	6.68 8.96	3050/264760	207
625/19											207
626/19	16.1 21.6	4100/355880	13.5 18.1	4000/347200	12.3 16.5	4100/355880	9.40 12.6	3600/312480	8.97 12.0	4100/355880	208
627/19	24.0 32.2	6100/529480	20.1 27.0	5950/516460	18.4 24.7	6140/532952	16.0 21.4	6150/533820	13.4 18.0	6140/532952	208

\* Please avoid use at the full input capacity and use within the allowable output torque for frame sizes shown in the   column.

\* Please refer to the Allowable Overhung Load for each frame size as shown on page 225.

Ratio	1 2 4 7 (43 x 29)		1 4 7 9 (87 x 17)		1 8 4 9 (43 x 43)		2 0 6 5 (59 x 35)		2 5 3 7 (59 x 43)		Dimension page
Output Speed(R.P.M.)	1.4		1.2		0.97		0.87		0.71		
Frame Size	Input kw/HP	Output Torque kgf.m/in.lbs	Input kw/HP	Output Torque kgf.m/in.lbs	Input kw/HP	Output Torque kgf.m/in.lbs	Input kw/HP	Output Torque kgf.m/in.lbs	Input kw/HP	Output Torque kgf.m/in.lbs	
607/07	0.10 0.13	2.50/217			0.10 0.13	2.50/217					191
608/07	0.10 0.13	5.10/443			0.10 0.13	5.10/443	0.10 0.13	5.10/443	0.10 0.13	5.10/443	191
609/08	0.10 0.13	13.0/1128	0.10 0.13	13.0/1128	0.10 0.13	13.0/1128	0.10 0.13	13.0/1128	0.10 0.13	13.0/1128	192
610/08	0.10 0.13	26.0/2257	0.10 0.13	26.0/2257	0.10 0.13	26.0/2257	0.10 0.13	26.0/2257	0.10 0.13	26.0/2257	192
611/08	0.10 0.13	51.0/4427	0.10 0.13	51.0/4427	0.10 0.13	51.0/4427	0.10 0.13	51.0/4427	0.10 0.13	51.0/4421	193
611/09											193
613/08	0.20 0.27	77.0/6684	0.20 0.27	77.0/6684	0.20 0.27	77.0/6684	0.20 0.27	77.0/6684	0.20 0.27	77.0/6684	194
613/09											194
613/10											195
614/08	0.20 0.27	103/8940	0.20 0.27	103/8940	0.20 0.27	103/8940	0.20 0.27	102/8854	0.20 0.27	103/8940	195
614/09											196
614/10											196
616/09	0.40 0.54	183/15884	0.40 0.54	183/15884	0.40 0.54	183/15884	0.20 0.27	183/15884	0.20 0.27	183/15884	197
616/10											197
616/11											198
617/09	0.49 0.66	278/24130	0.41 0.55	278/24130	0.40 0.54	278/24130	0.40 0.54	278/24130	0.40 0.54	278/24130	198
617/10											199
617/11											199
618/10	0.75 1.00	410/35588	0.75 1.00	410/35588	0.75 1.00	410/35588	0.75 1.00	410/35588	0.40 0.54	410/35588	200
618/13											200
619/11	1.28 1.72	730/63364	1.08 1.45	730/63364	0.87 1.17	730/63364	0.78 1.05	730/63364	0.75 1.00	730/63364	201
619/13			1.08 1.45	730/63364							201
620/11	1.42 1.90	810/70308			1.50 2.01	810/70308	1.50 2.01	795/69006	0.75 1.00	785/68138	202
620/13	2.20 2.95	840/7291211			1.50 2.01	840/72912	1.50 2.01	840/72912	0.75 1.00	840/72912	202
621/13	2.20 2.95	1140/98952	1.50 2.01	950/82460	1.50 2.01	1140/98952	1.50 2.01	1140/98952	1.50 2.01	1140/98952	203
621/16											203
622/13	2.53 3.39	1440/124992	1.90 2.55	1280/11104	1.71 2.29	1440/124992	1.53 2.05	1440/124992	1.50 2.01	1440/124992	204
622/17											204
623/16	3.20 4.29	1820/157976	2.40 3.22	1620/140616	2.20 2.95	1820/157976	2.20 2.95	1820/157976	2.20 2.95	1820/157976	205
623/18											205
624/16	4.14 5.55	2350/203980	3.04 4.08	2050/177940	2.79 3.74	2350/203980	2.50 3.35	2350/203980	2.20 2.95	2350/203980	206
624/18											206
625/17	5.37 7.20	3050/264740	4.08 5.47	2750/238700	3.70 4.96	3050/264740	3.70 4.96	3050/264740	3.70 4.96	3050/264740	207
625/19											207
626/19	7.22 9.68	4100/355880	5.50 7.38	3692/20466	5.50 7.38	4100/355880	5.50 7.38	4100/355880	5.50 7.38	4100/355880	208
627/19	11.0 14.8	6150/533820	11.0 14.8	6150/533820	7.50 10.0	6150/533820	7.50 10.0	6150/533820	7.50 10.0	6150/533820	208

\* Please avoid use at the full input capacity and use within the allowable output torque for frame sizes shown in the   column.

\* Please refer to the Allowable Overhung Load for each frame size as shown on page 225.



Ratio	3045 (87x35)		3481 (59x59)		4437 (87x51)		5133 (87x59)		6177 (87x71)		7569 (87x87)		Dimension page
Output Speed(R.P.M.)	0.49		0.43		0.34		0.29		0.24		0.20		
Frame Size	Input kw/HP	Output Torque kgf.m/in.lbs	Input kw/HP	Output Torque kgf.m/in.lbs	Input kw/HP	Output Torque kgf.m/in.lbs	Input kw/HP	Output Torque kgf.m/in.lbs	Input kw/HP	Output Torque kgf.m/in.lbs	Input kw/HP	Output Torque kgf.m/in.lbs	
607/07													191
608/07													191
609/08	0.10 0.13	13.0/1128	0.10 0.13	13.0/1128	0.10 0.13	13.0/1128	0.10 0.13	13.0/1128					192
610/08	0.10 0.13	51.0/4427	0.10 0.13	26.0/2257	0.10 0.13	26.0/2257	0.10 0.13	26.0/2257					192
611/08	0.10 0.13	51.0/4427	0.10 0.13	51.0/4427	0.10 0.13	51.0/4427	0.10 0.13	51.0/4427					193
611/09									0.10 0.13	51.0/4427	0.10 0.13	51.0/4427	193
6213/08	0.20 0.27	77.0/6684	0.20 0.27	77.0/6684	0.20 0.27	77.0/6684	0.20 0.27	77.0/6684					194
613/09									0.20 0.27	77.0/6684	0.20 0.27	77.0/6684	194
613/10													195
614/08	0.20 0.27	103/8940	0.20 0.27	103/8940	0.20 0.27	103/8940	0.20 0.27	103/8940					195
614/09									0.20 0.27	103/8940	0.20 0.27	103/8940	196
614/10													196
616/09	0.20 0.27	183/15884	0.20 0.27	183/15884	0.20 0.27	183/15884	0.20 0.27	183/15884	0.20 0.27	183/15884	0.20 0.27	183/15884	197
616/10													197
616/11													198
617/09	0.20 0.27	278/24130	0.20 0.27	278/24130	0.20 0.27	278/24130	0.20 0.27	278/24130	0.20 0.27	278/24130	0.20 0.27	278/24130	198
617/10													199
617/11													199
618/10	0.40 0.54	410/35588	0.40 0.54	410/35588	0.40 0.54	410/35588	0.40 0.54	410/35588	0.40 0.54	410/35588	0.40 0.54	410/35588	200
618/13													200
619/11	0.75 1.00	730/63364	0.75 1.00	730/63364	0.75 1.00	730/63364	0.75 1.00	730/63364	0.75 1.00	730/63364	0.75 1.00	730/63364	201
619/13													201
620/11			0.75 1.00	860/74648			0.75 1.00	860/74648					202
620/13													202
621/13	1.50 2.01	950/82460	1.50 2.01	1140/98952	1.50 2.01	950/82460	1.50 2.01	1140/98952	1.50 2.01	950/82460	1.50 2.01	950/82460	203
621/16													203
622/13	1.50 2.01	1275/110670	1.50 2.01	1440/124992	1.50 2.01	1275/110670	1.50 2.01	1440/124992	1.50 2.01	1275/110670	1.50 2.01	1275/110670	204
622/17													204
623/16	2.20 2.95	1600/138880	2.20 2.95	1810/157108	2.20 2.95	1600/138880	2.20 2.95	1810/157108	2.20 2.95	1600/138880	2.20 2.95	1600/138880	205
623/18													205
624/16	2.20 2.95	2050/177940	2.20 2.95	2350/233980	2.20 2.95	2050/177940	2.20 2.95	2350/203980	2.20 2.95	2050/177940	2.20 2.95	2050/177940	206
624/18													206
625/17	3.70 4.96	2650/230020	3.70 4.96	3050/264740	3.70 4.96	2650/230020	3.70 4.96	3050/264740	3.70 4.96	2650/230020	3.70 4.96	2650/230020	207
625/19													207
626/19	5.50 7.38	3520/305536	5.50 7.38	4100/355880	5.50 7.38	3520/305536	5.50 7.38	4100/355880	5.50 7.38	3520/305536	5.50 7.38	3500/303800	208
627/19	7.50 10.0	6150/533820	7.50 10.0	6150/533820	7.50 10.0	6150/533820	7.50 10.0	6150/533820	7.50 10.0	6150/533820	7.50 10.0	6150/533820	208

\* Please avoid use at the full input capacity and use within the allowable output torque for frame sizes shown in the  column.

\* Please refer to the Allowable Overhung Load for each frame size as shown on page 225.



# DIMENSION DRAWINGS Single Stage Reduction, Horizontal TRANSCYKO Speed Reducers

TH-607 Weight 2.5kg,5.5lbs

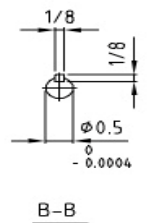
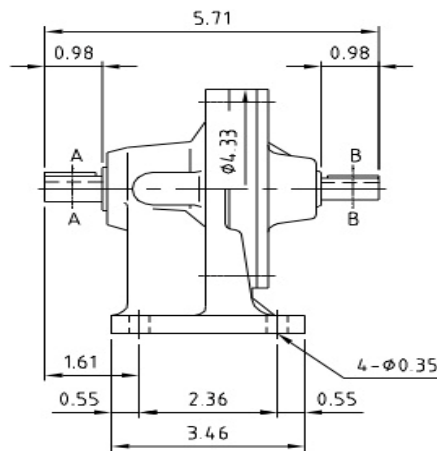
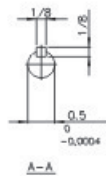
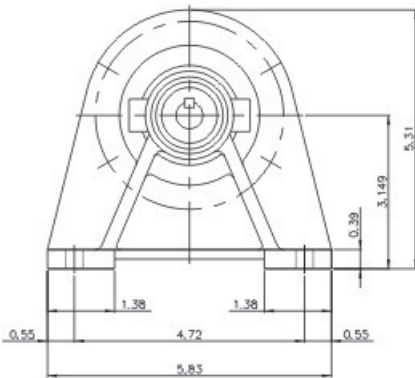
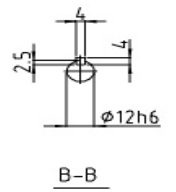
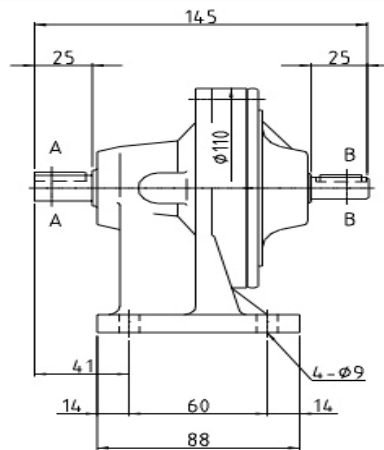
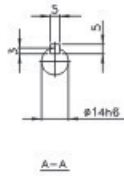
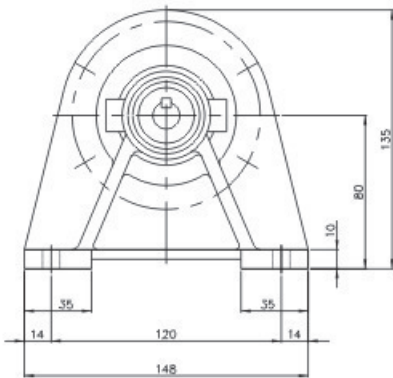

TH-608 Weight 2.5kg,5.5lbs

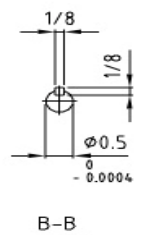
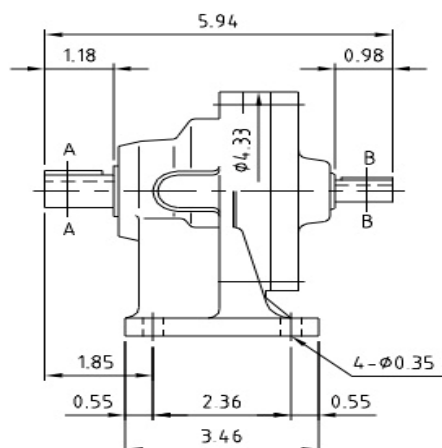
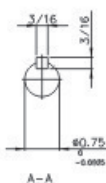
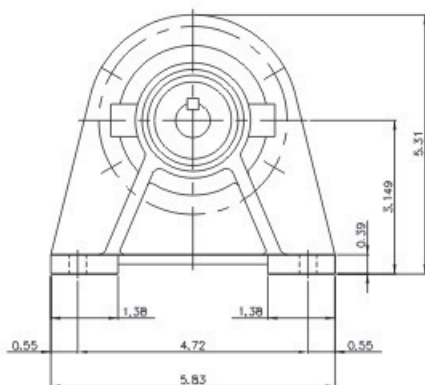
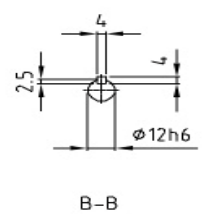
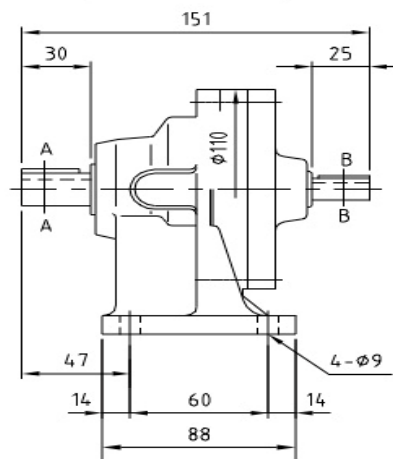
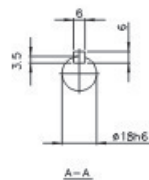
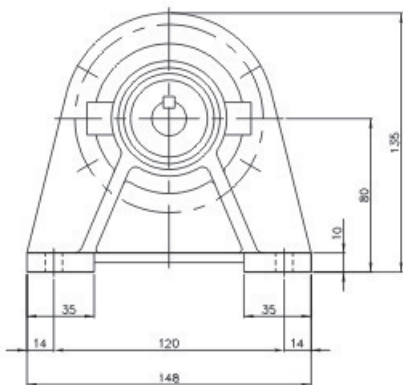

TH-609 Weight 12kg,26lbs

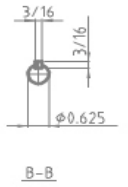
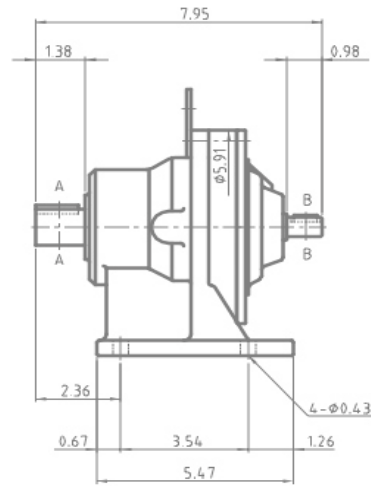
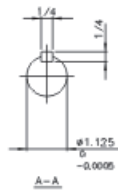
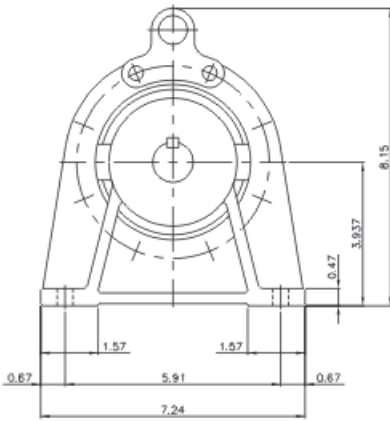
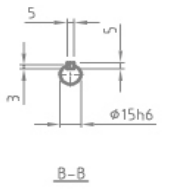
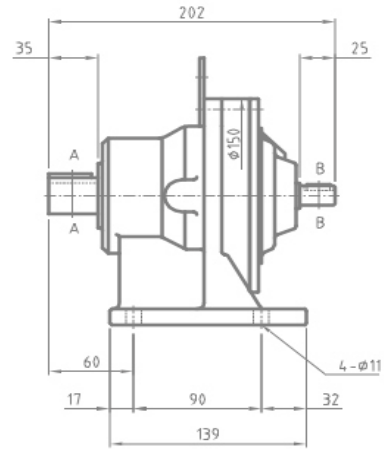
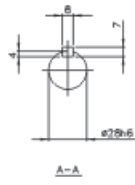
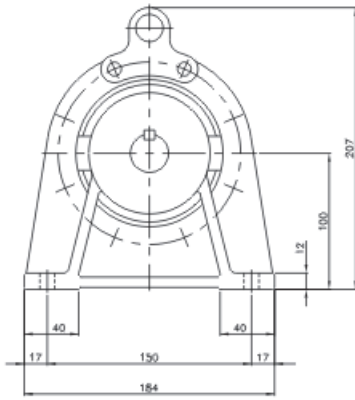

TH-610 Weight 13kg,29lbs

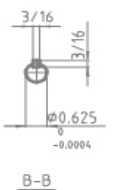
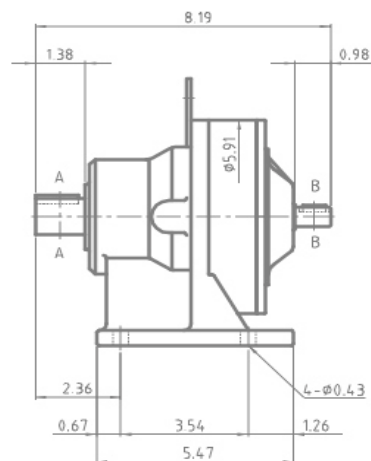
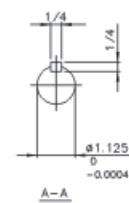
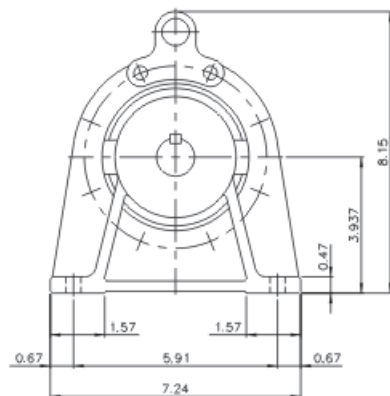
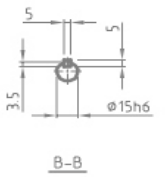
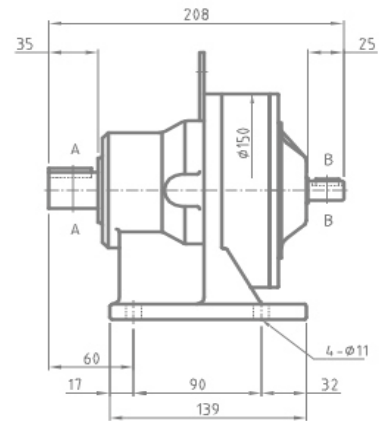
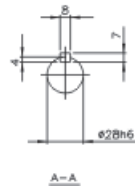
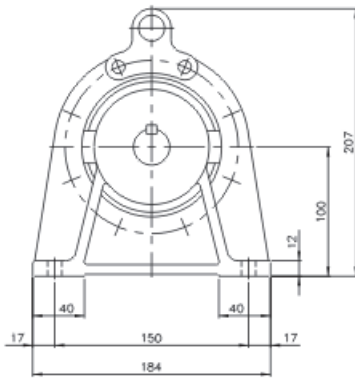

TH-611 Weight 24kg,53lbs

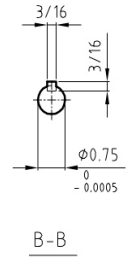
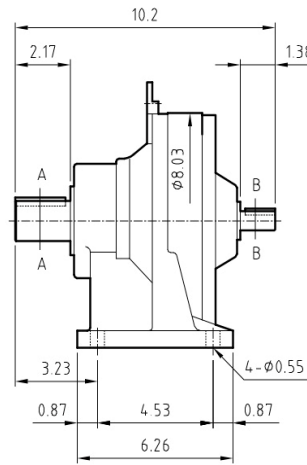
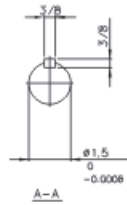
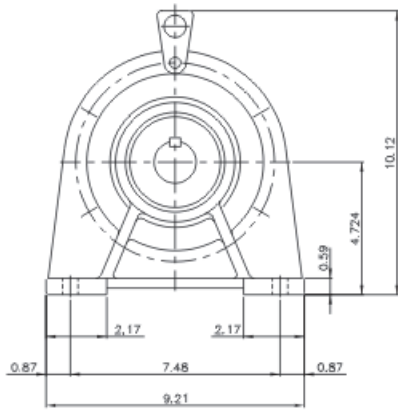
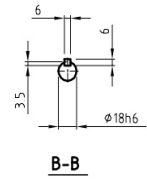
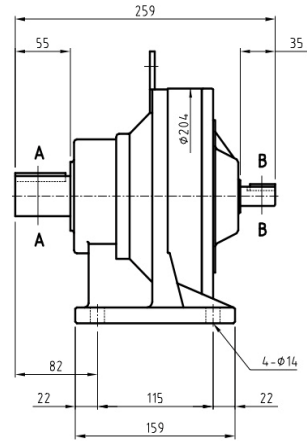
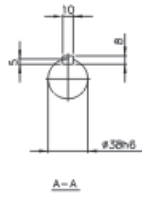
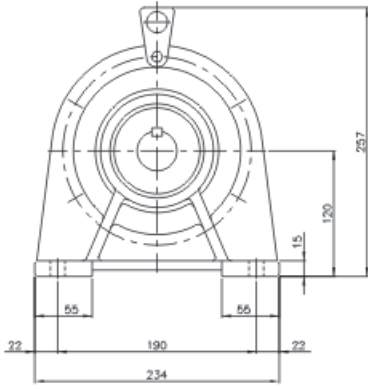

TH-612 Weight 25kg,55lbs

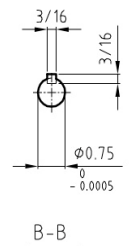
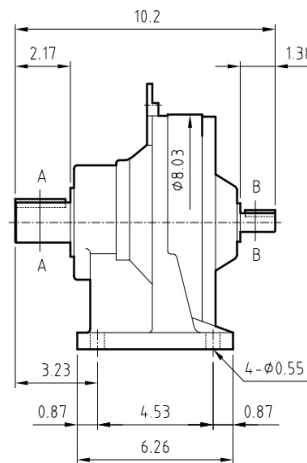
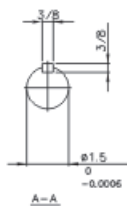
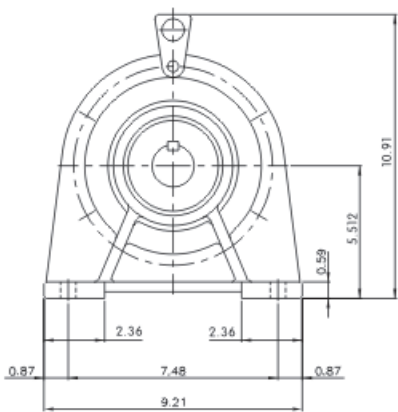
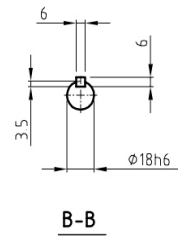
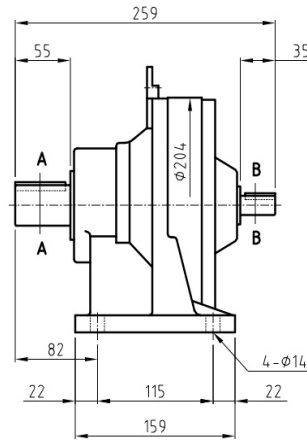
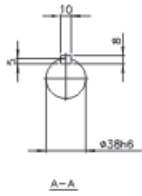
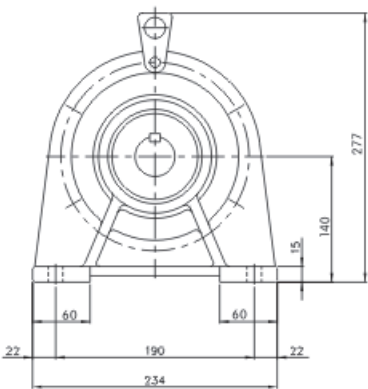



THH-613 Weight 43kg,95lbs

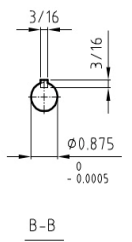
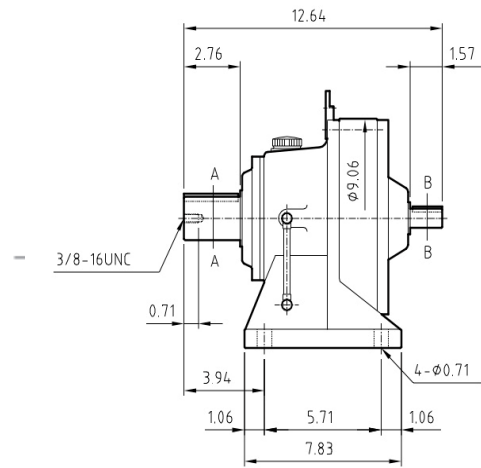
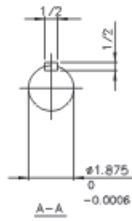
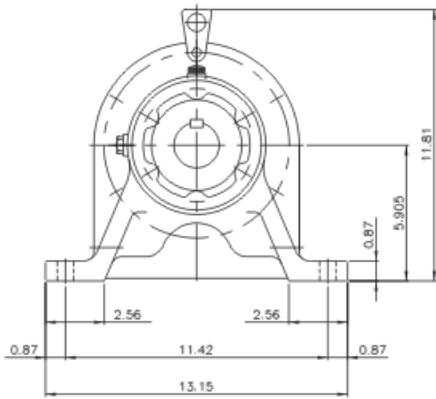
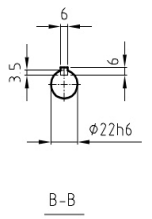
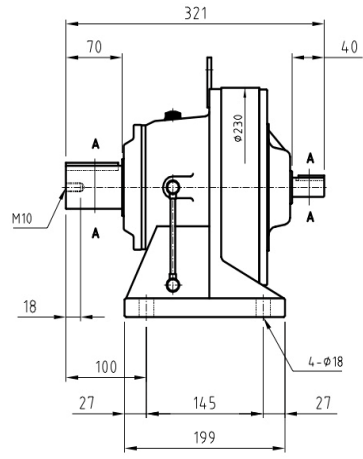
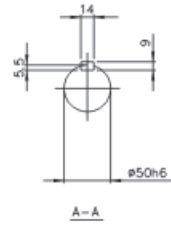
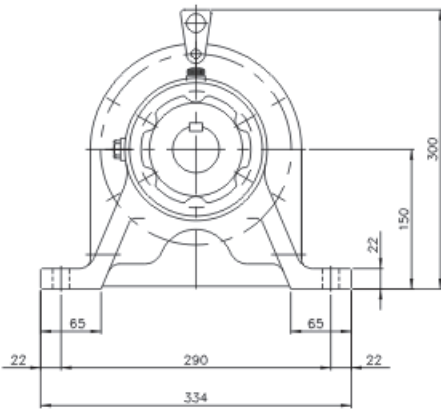

THH-614 Weight 44kg,97lbs

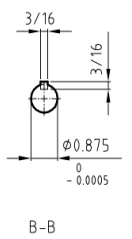
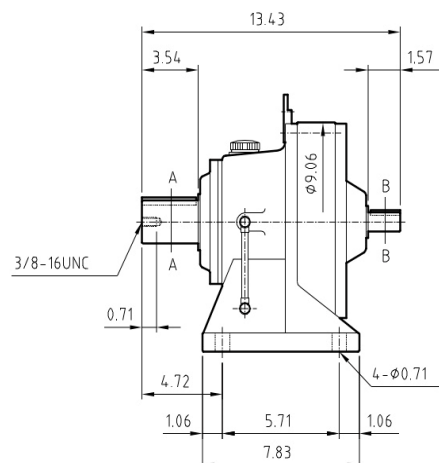
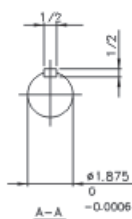
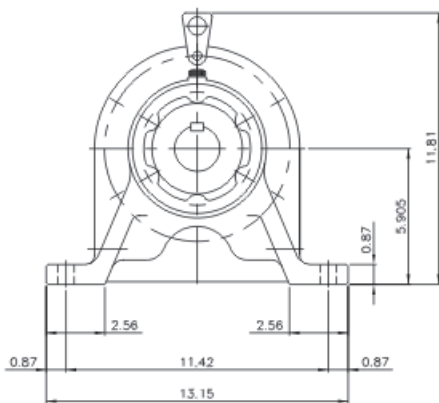
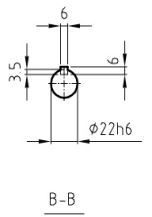
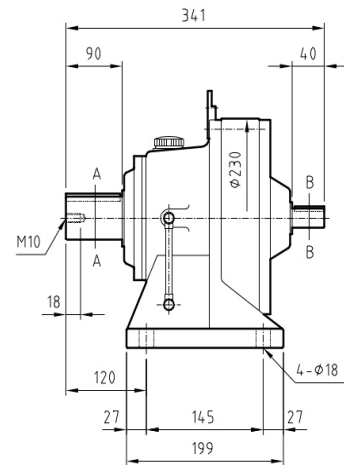
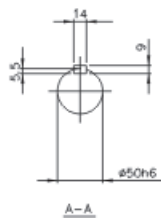
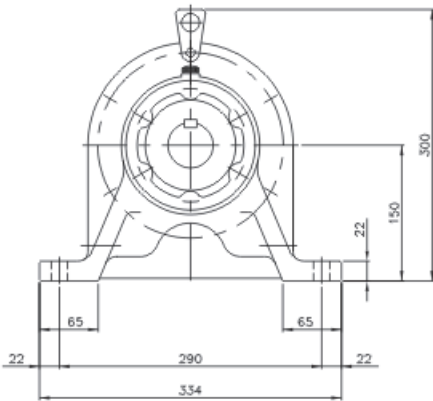

THH-615 Weight 46kg,101lbs

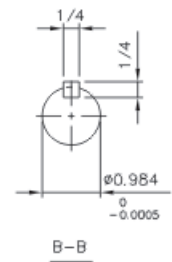
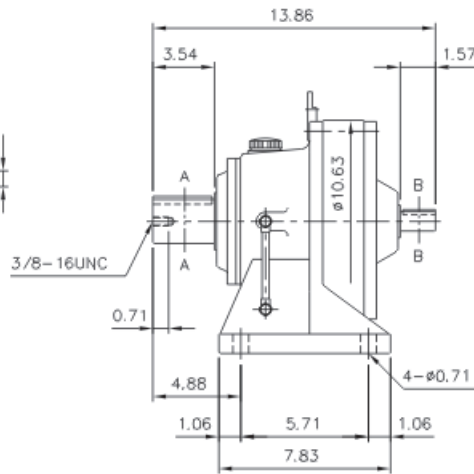
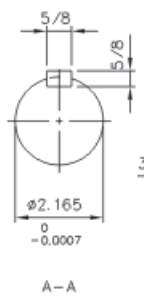
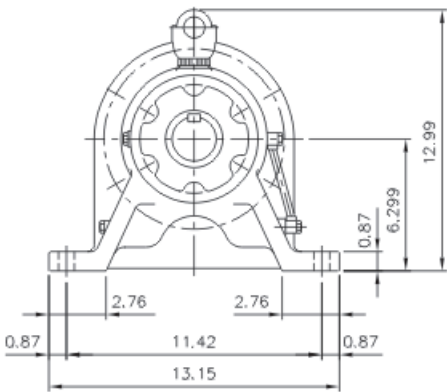
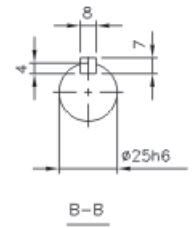
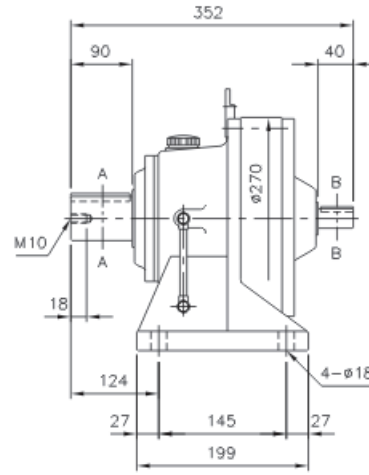
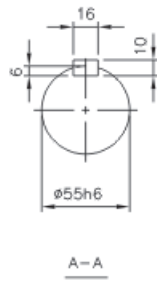
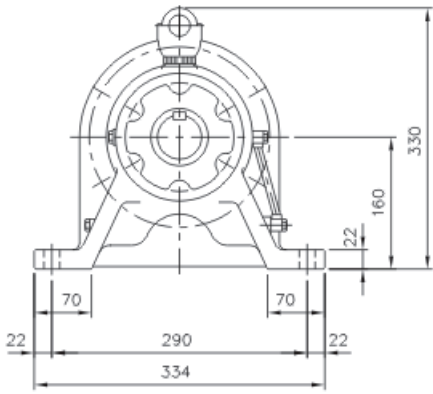

THH-616 Weight 85kg,187lbs

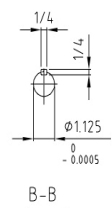
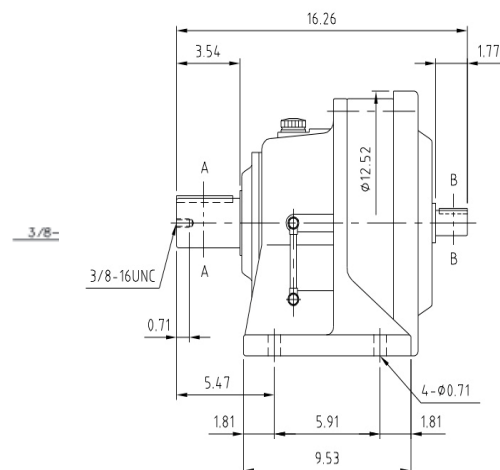
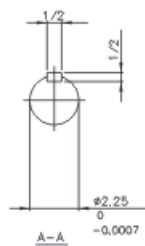
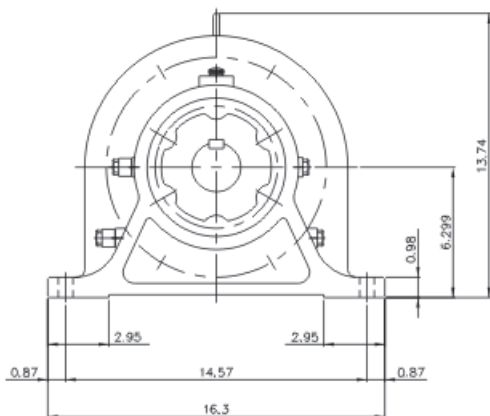
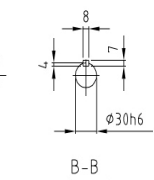
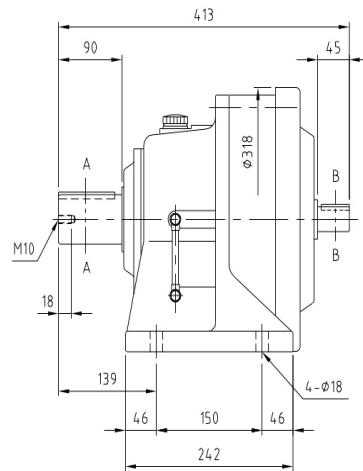
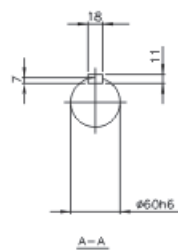
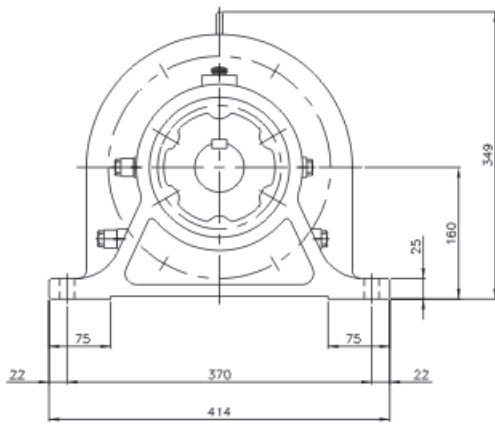

THH-617 Weight 125kg,275lbs

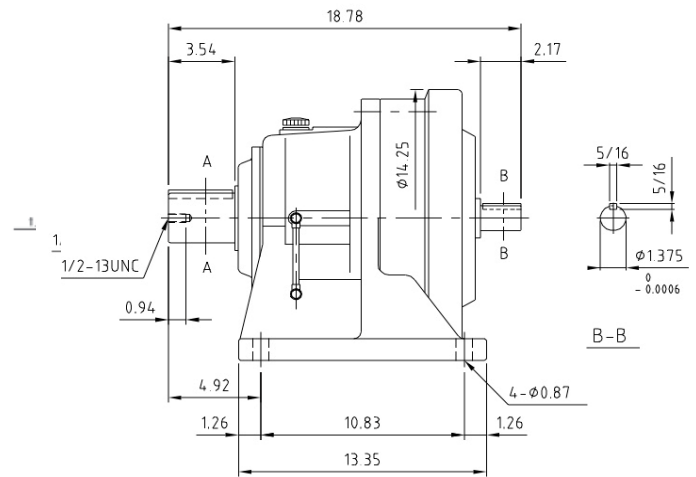
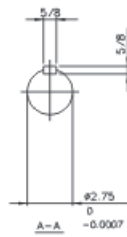
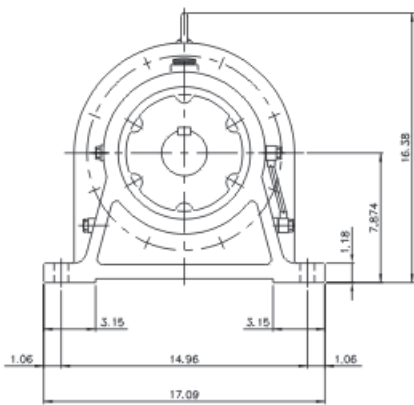
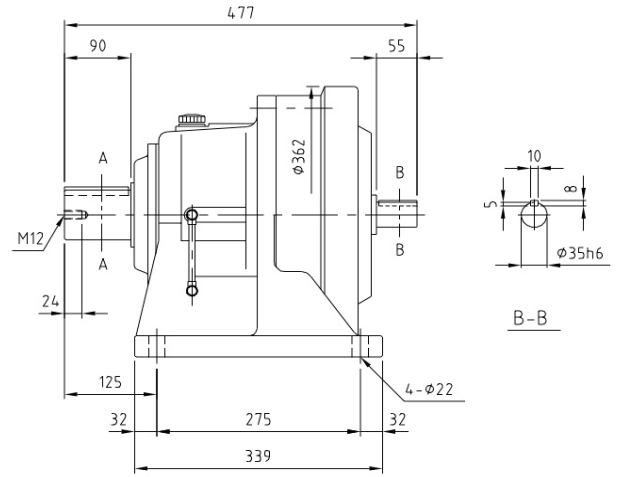
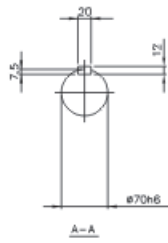
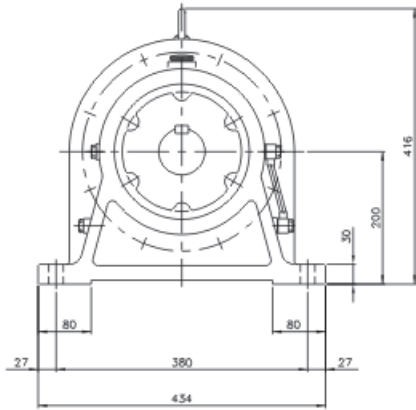

THH-618 Weight 162kg,356lbs

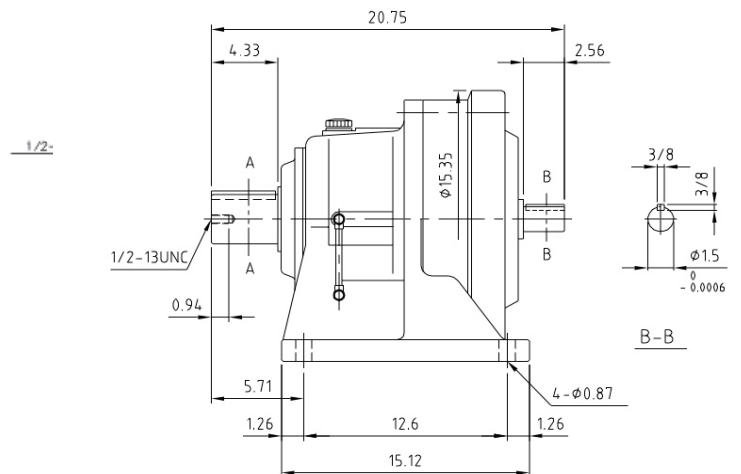
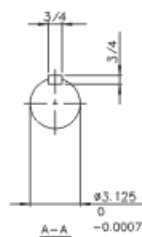
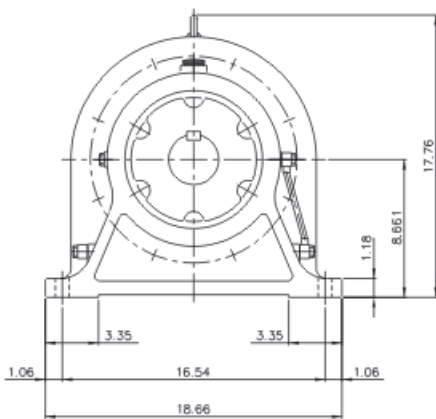
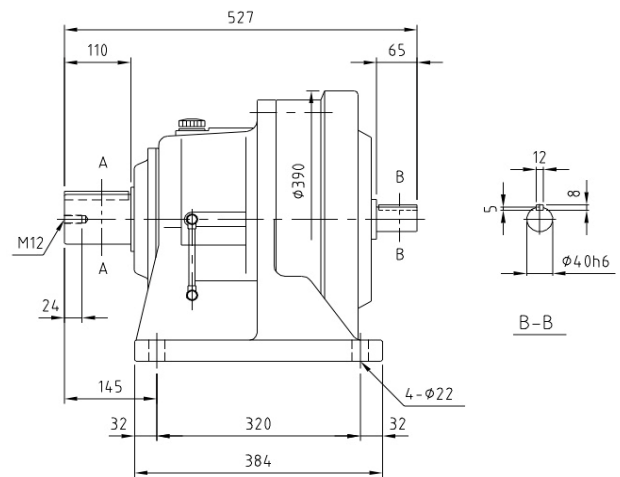
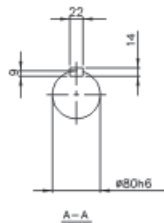
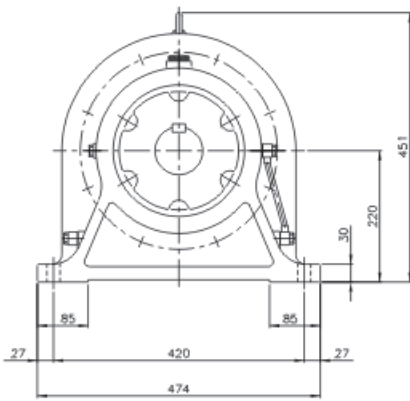



THH-619 Weight 46kg,101lbs

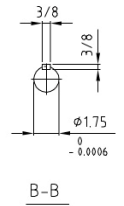
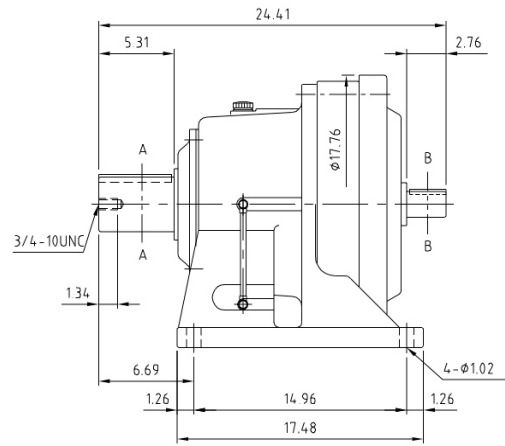
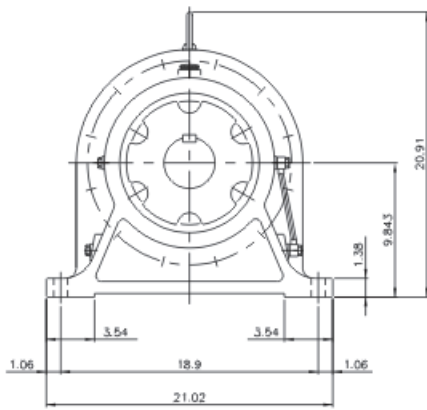
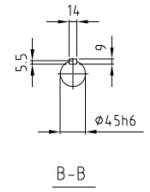
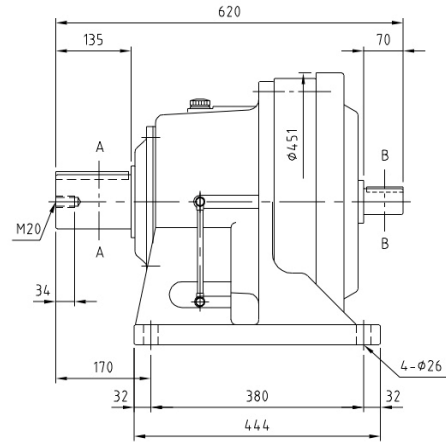
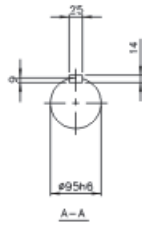
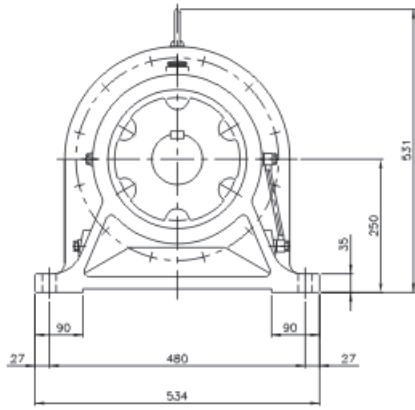

THH-620 Weight 256kg,563lbs

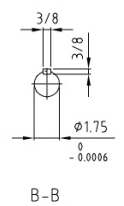
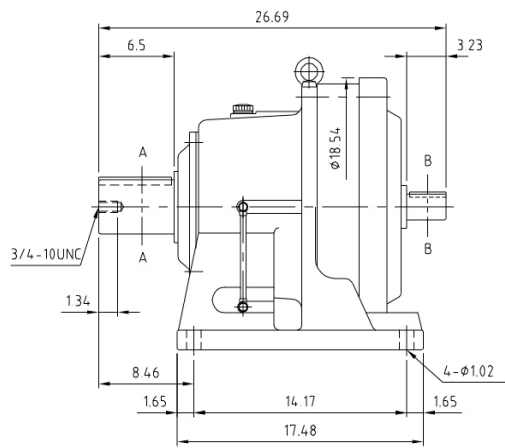
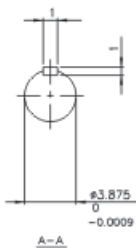
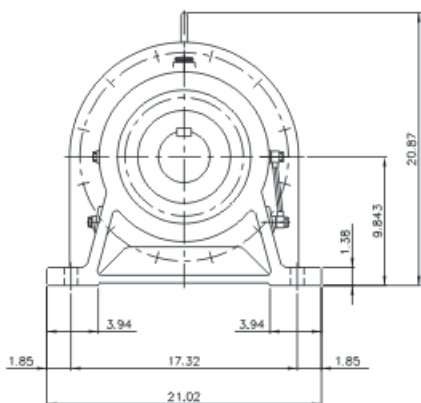
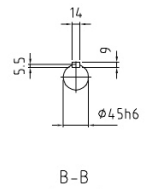
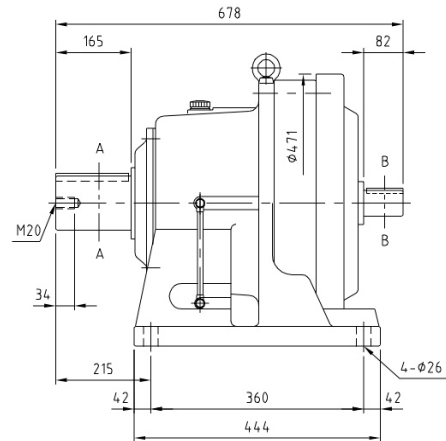
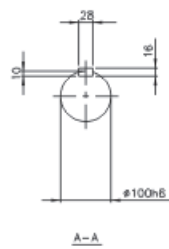
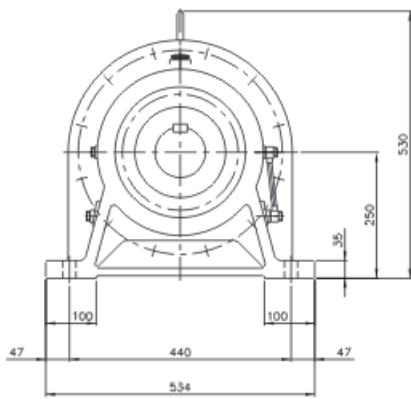

**THH-621 Weight 336kg,739lbs**

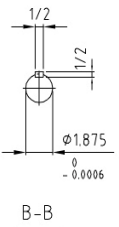
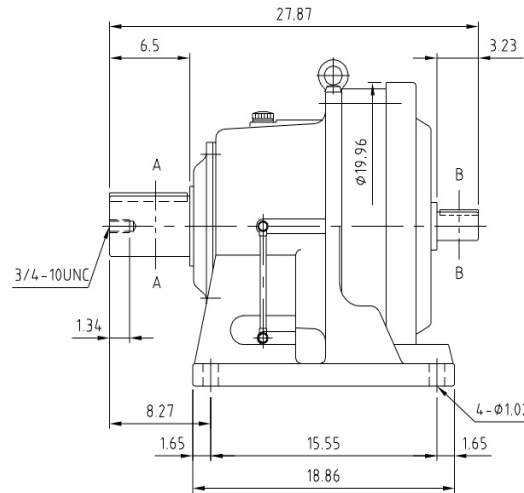
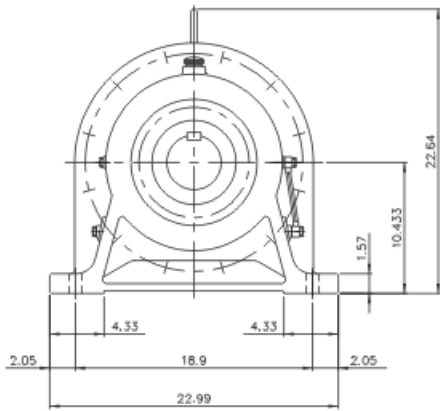
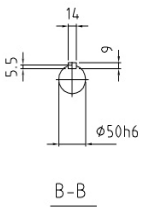
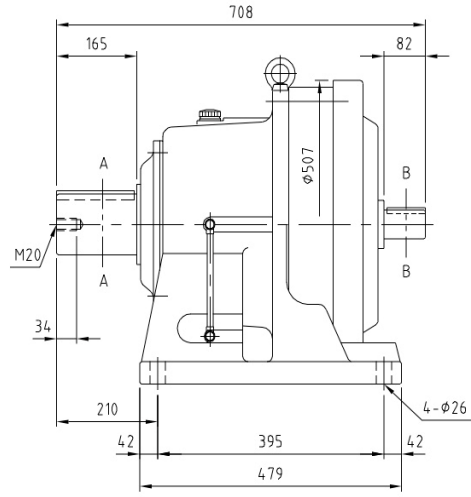
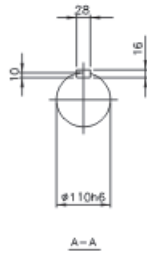
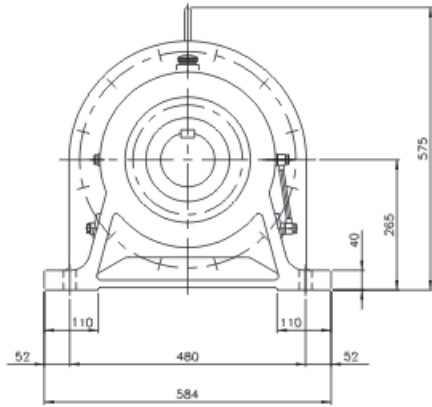

**THH-622 Weight 412kg,906lbs**

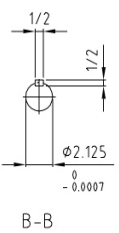
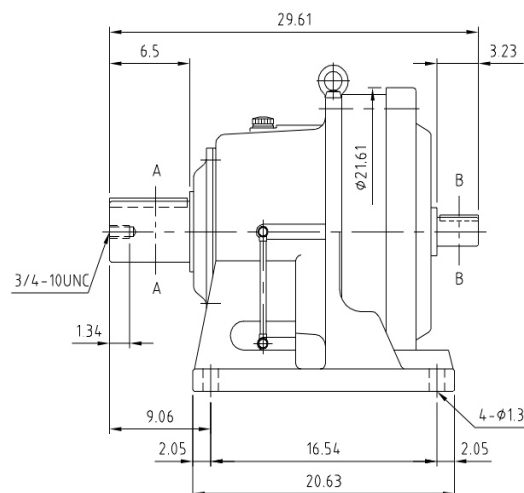
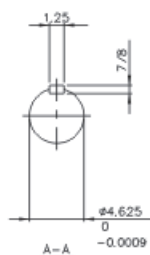
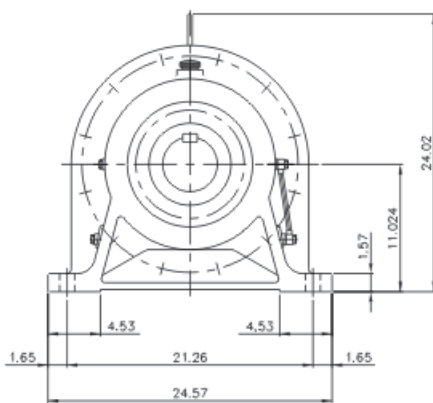
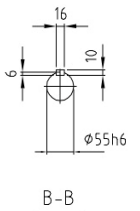
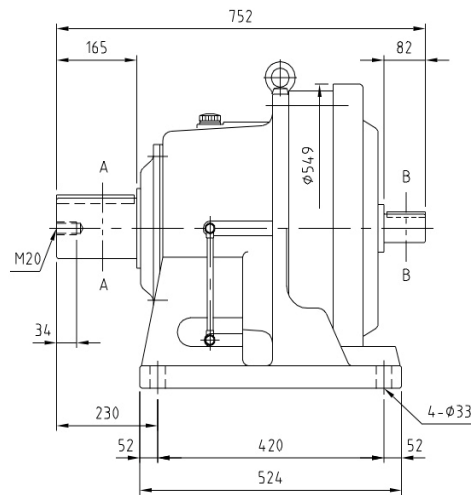
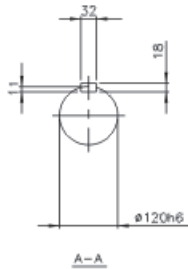
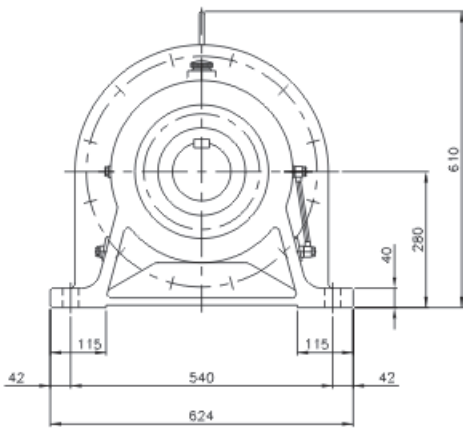

THH-623 Weight 503kg,1107 lbs

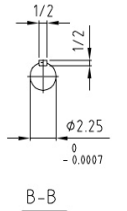
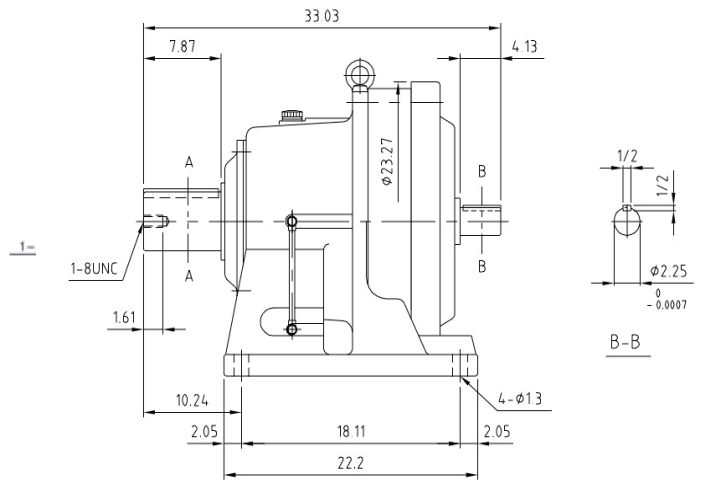
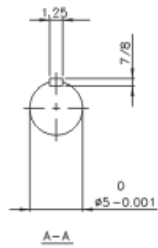
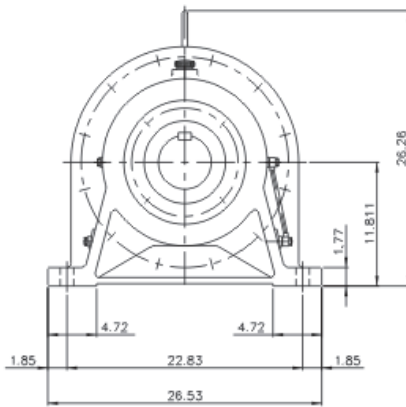
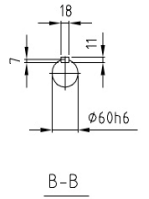
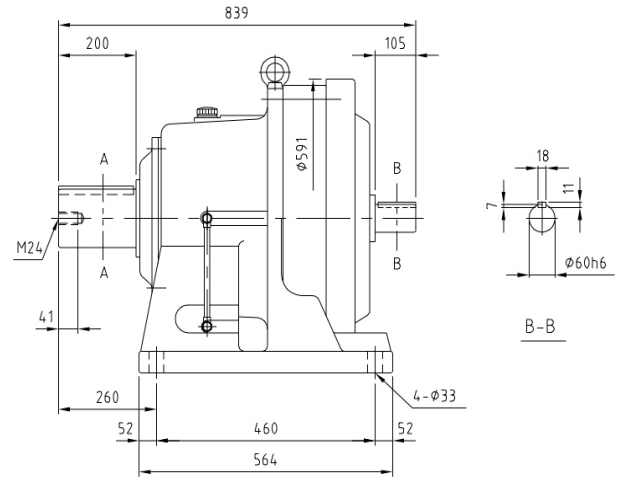
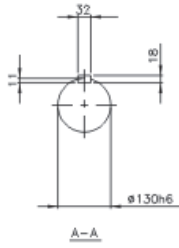
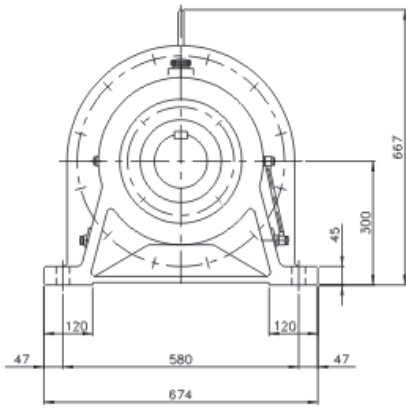

THH-624 Weight 616kg,1355 lbs

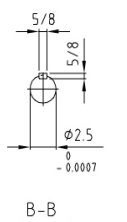
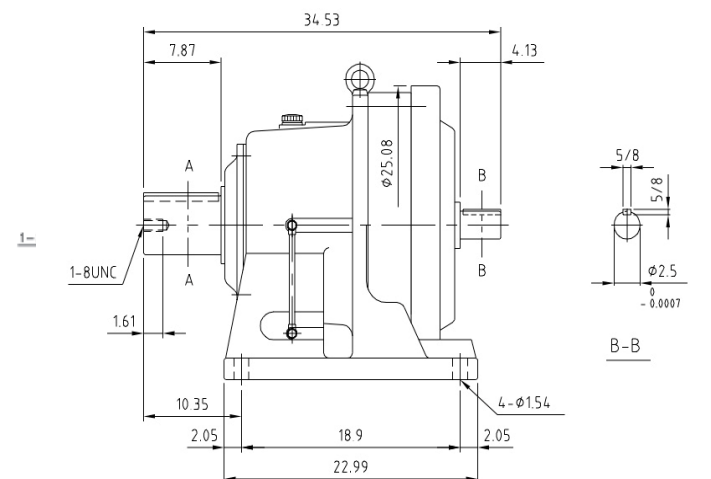
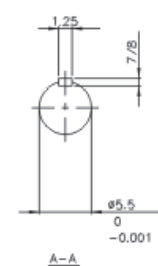
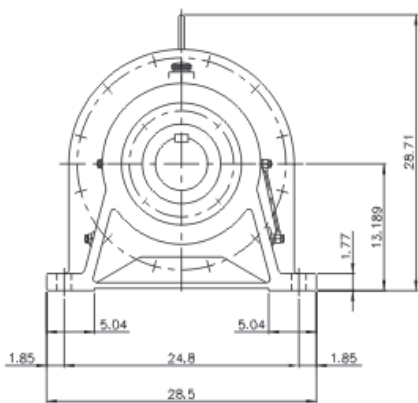
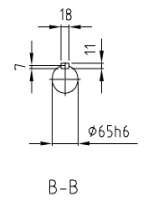
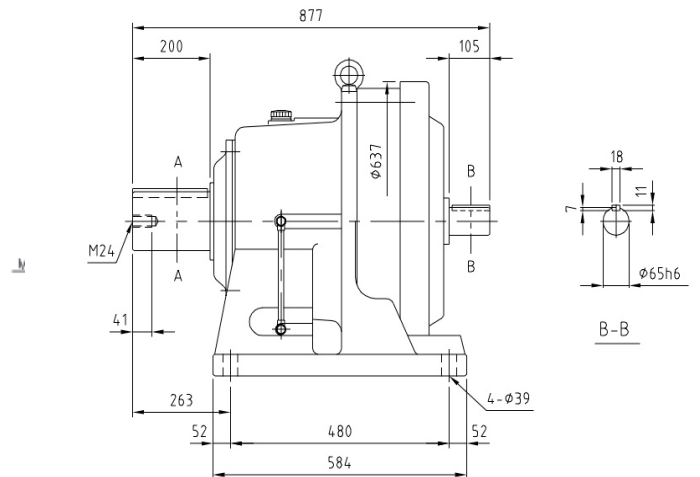
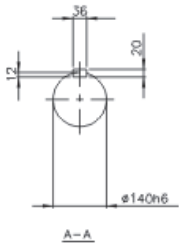
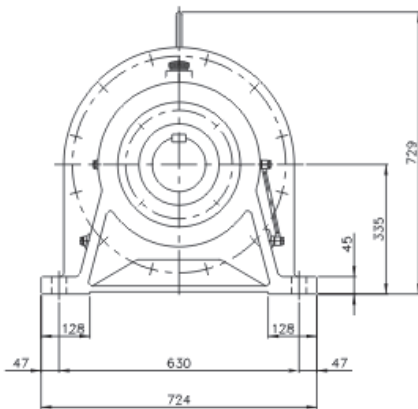



THH-625 Weight 955kg,2101 lbs

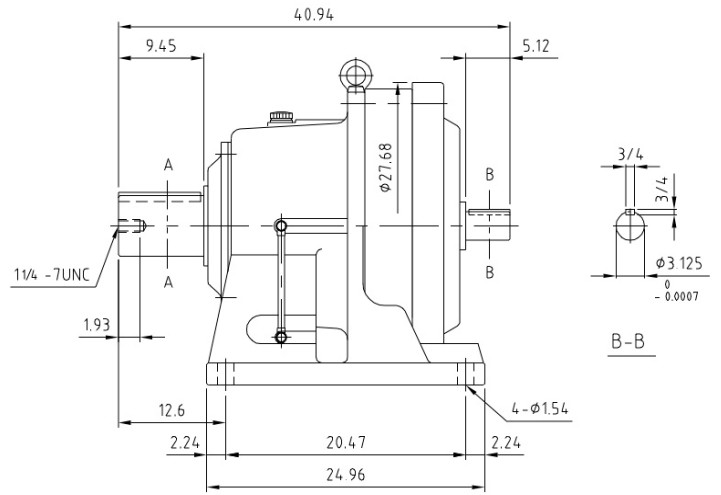
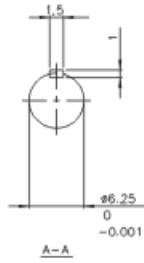
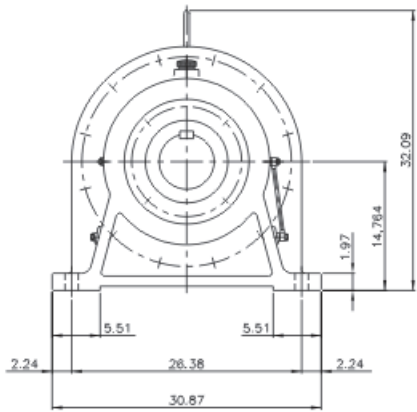
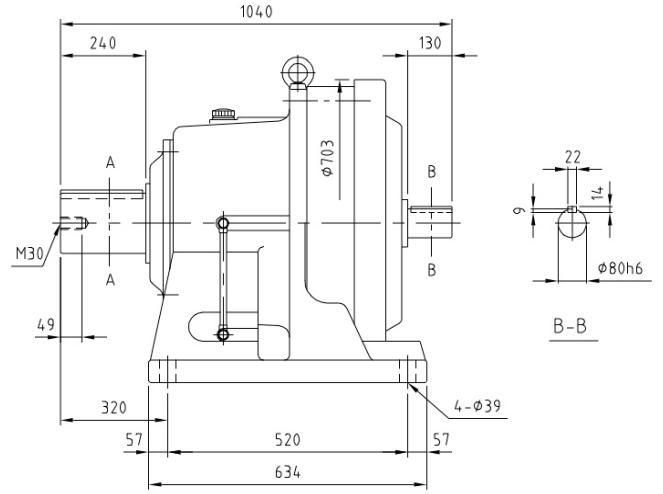
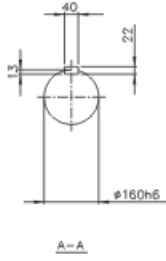
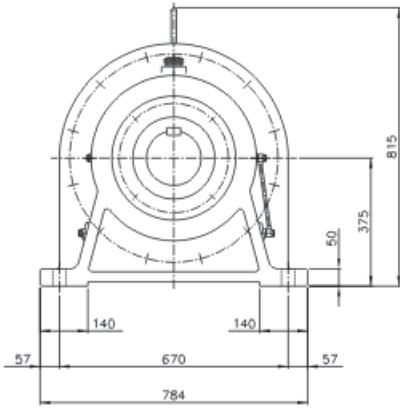

THH-626 Weight 1190kg,2618 lbs

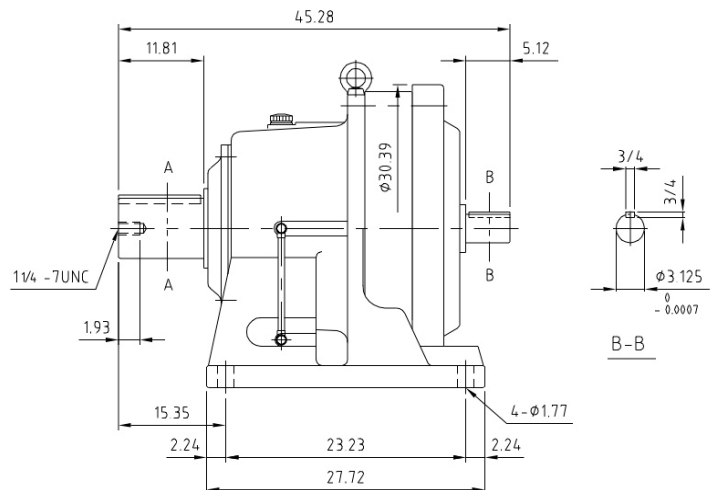
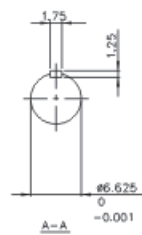
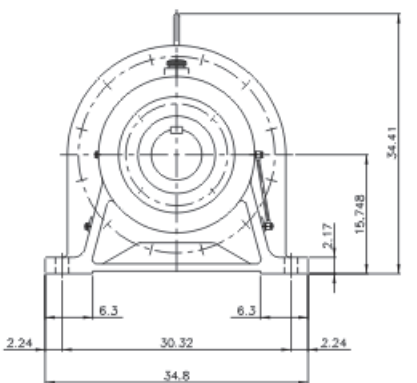
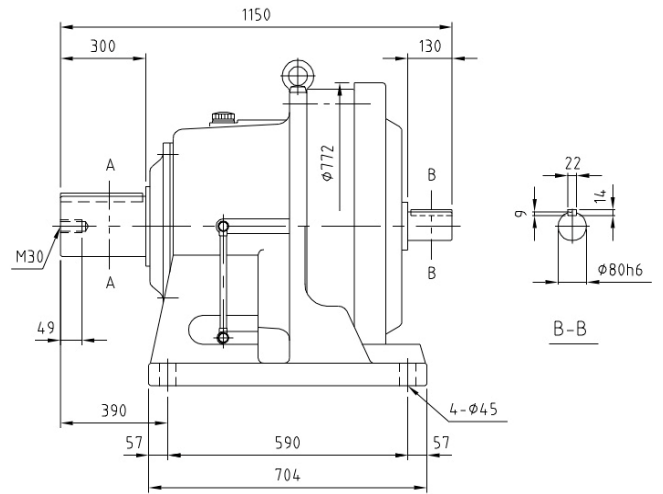
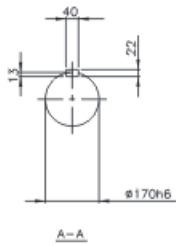
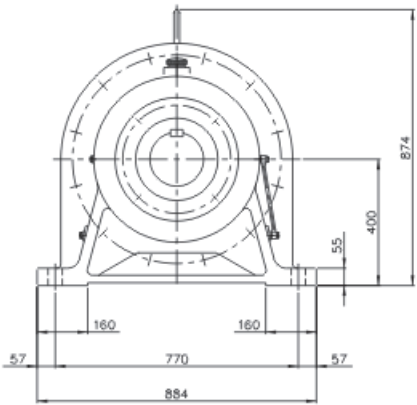

THH-627 Weight 2460kg,5412 lbs

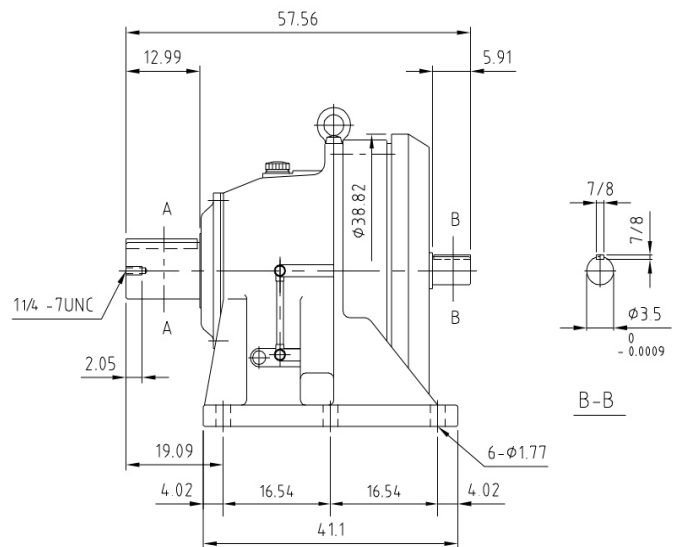
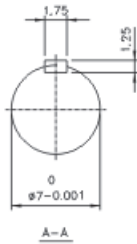
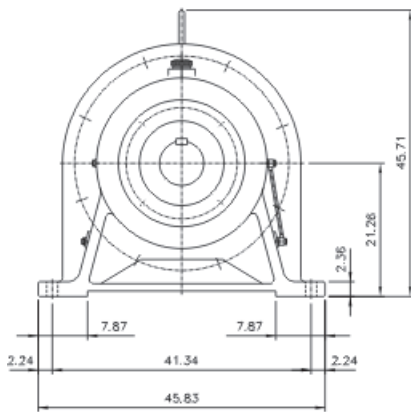
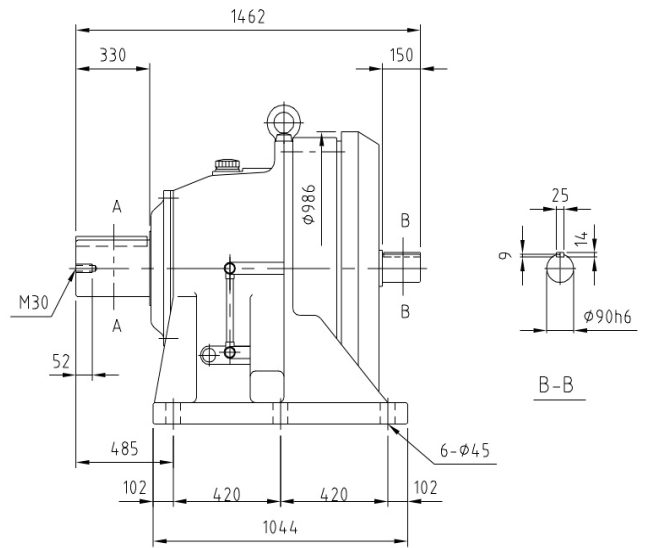
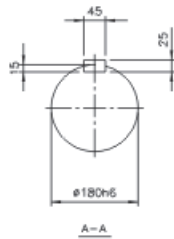
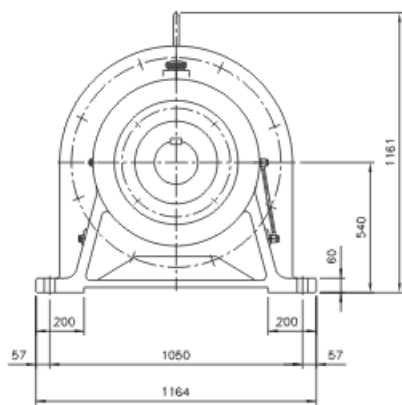

# DIMENSION DRAWINGS Double Stage Reduction, Horizontal TRANSCYKO Speed Reducers

TH-607/07 Weight 4kg,9 lbs

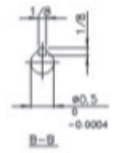
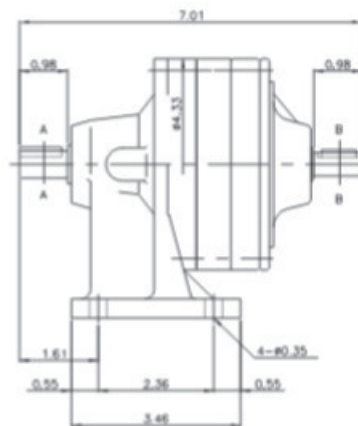
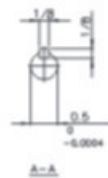
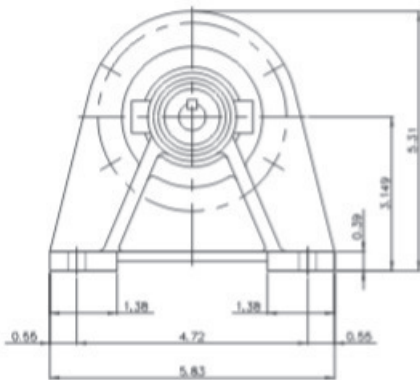
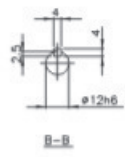
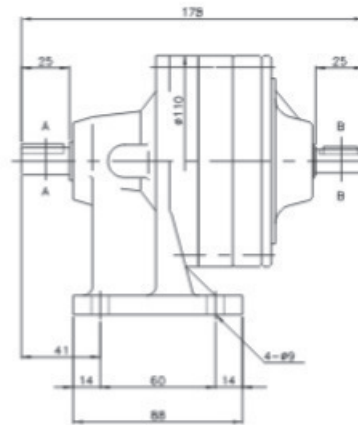
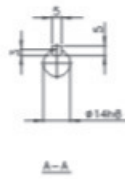
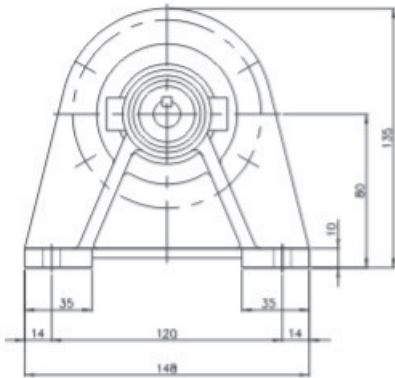

TH-608/07 Weight 4.5kg,10 lbs

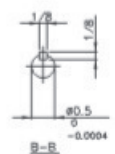
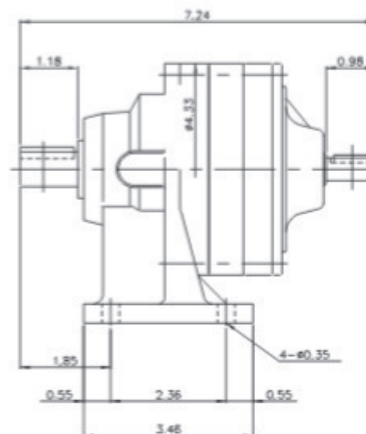
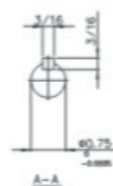
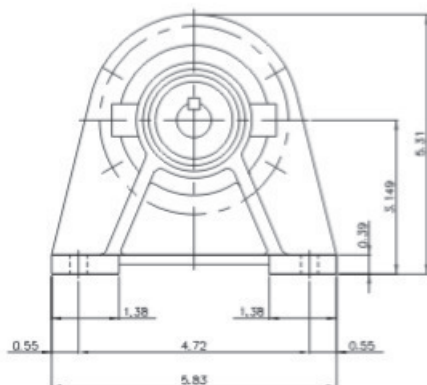
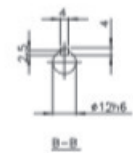
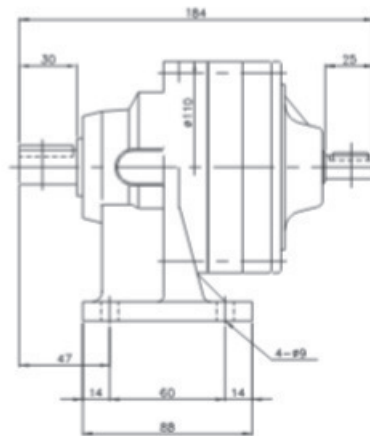
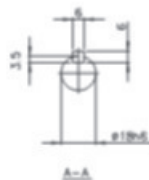
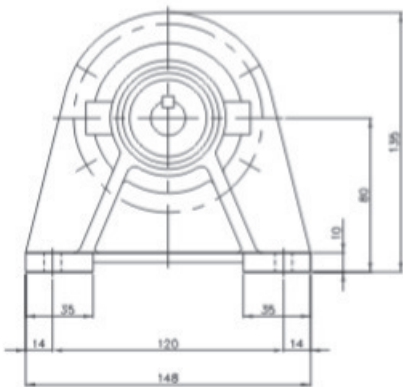



TH-609/08 Weight 13kg,29lbs

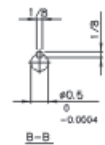
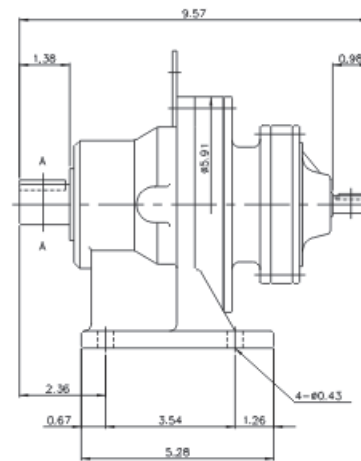
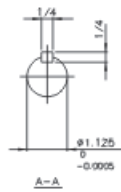
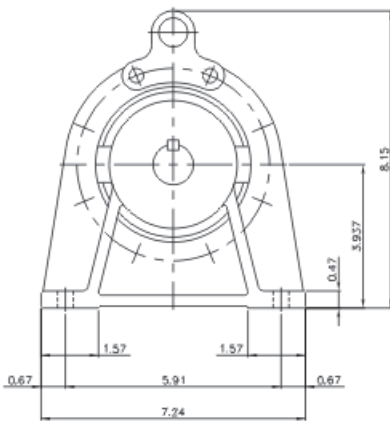
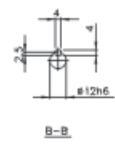
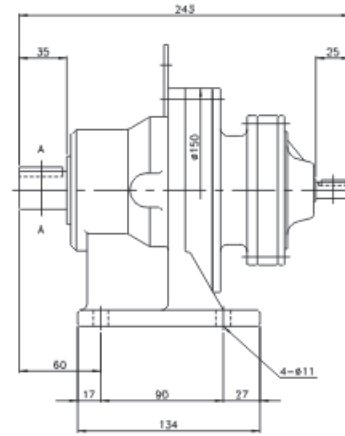
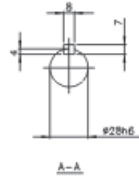
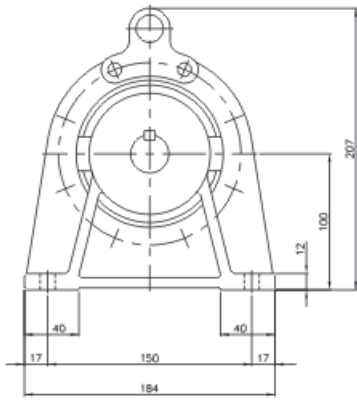

TH-610/8 Weight 15kg,33lbs

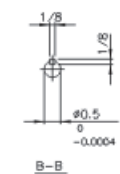
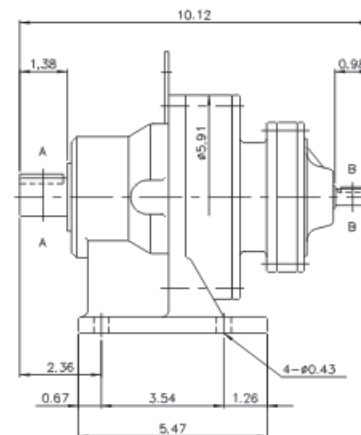
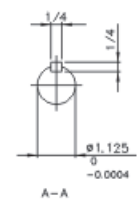
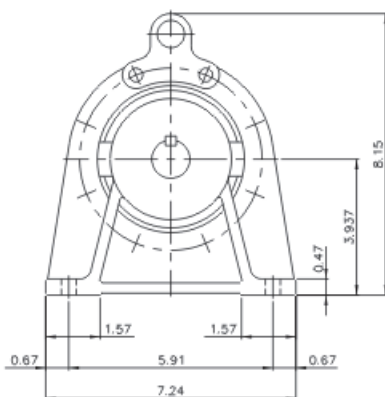
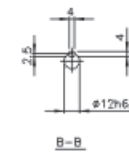
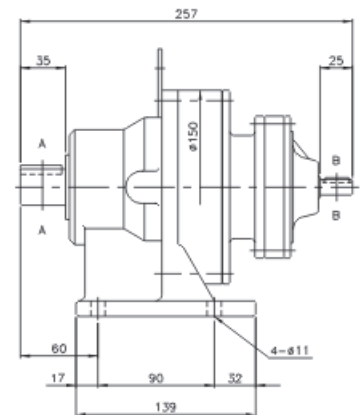
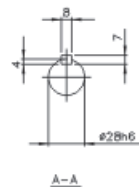
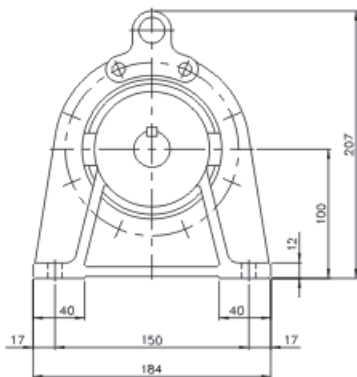

TH-611/08 Weight 25kg,55lbs

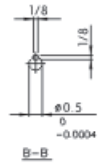
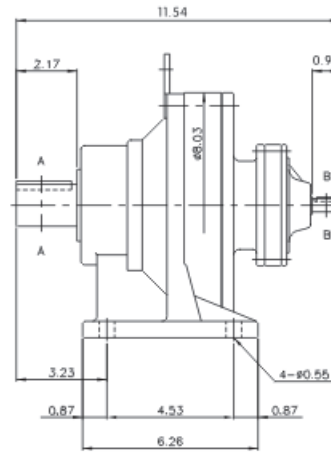
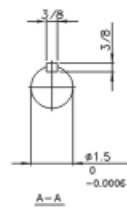
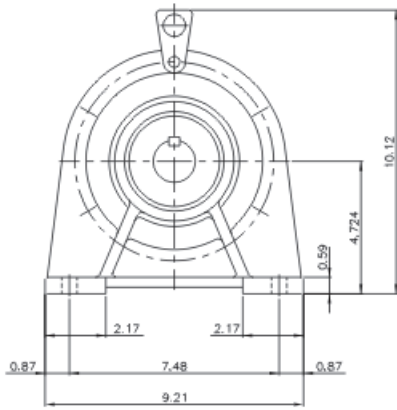
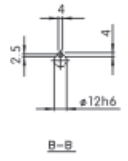
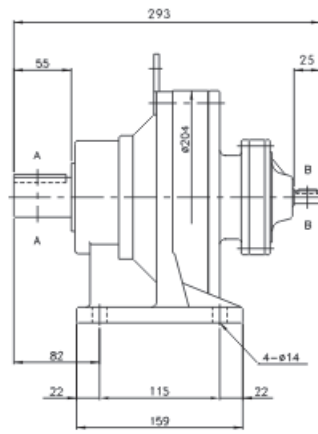
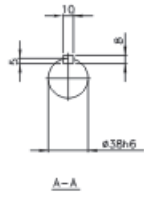
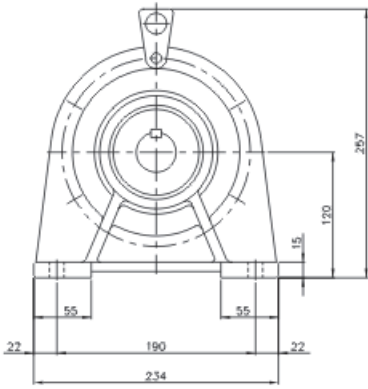

TH-611/09 Weight 25kg,55lbs

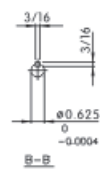
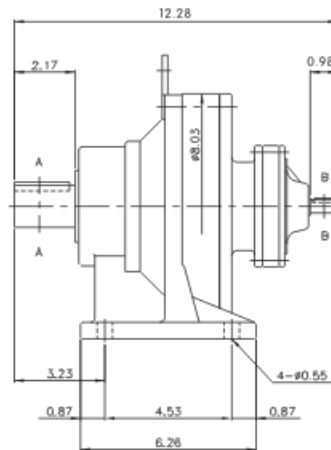
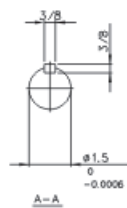
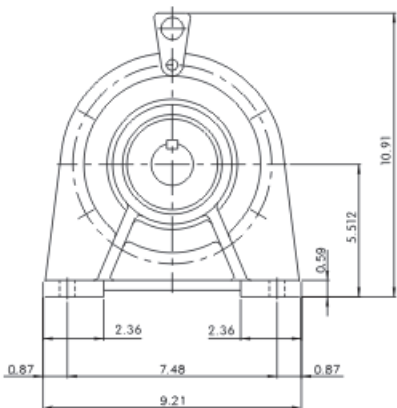
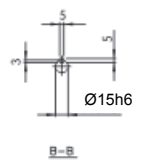
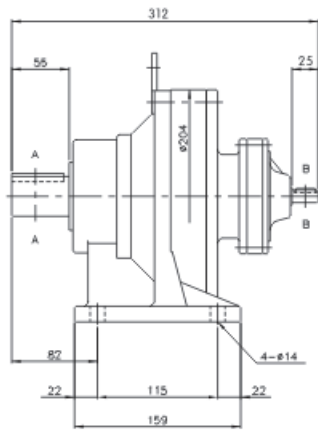
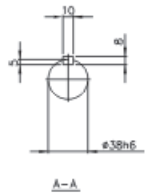
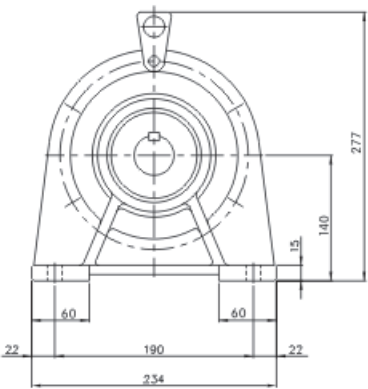

TH-613/08 Weight 42kg,92 lbs

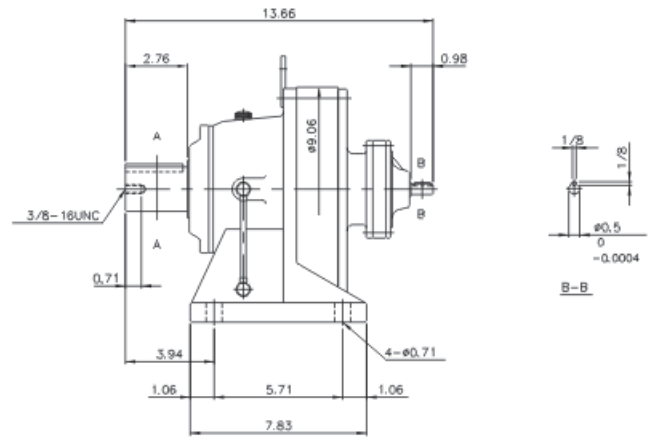
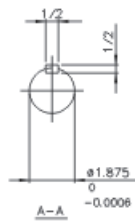
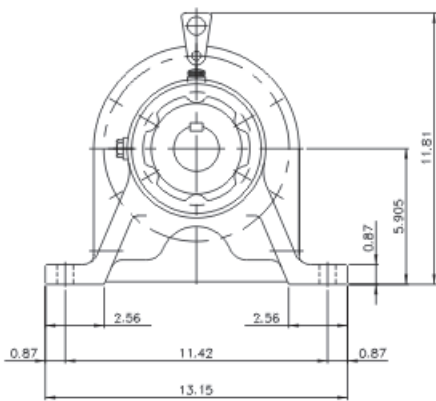
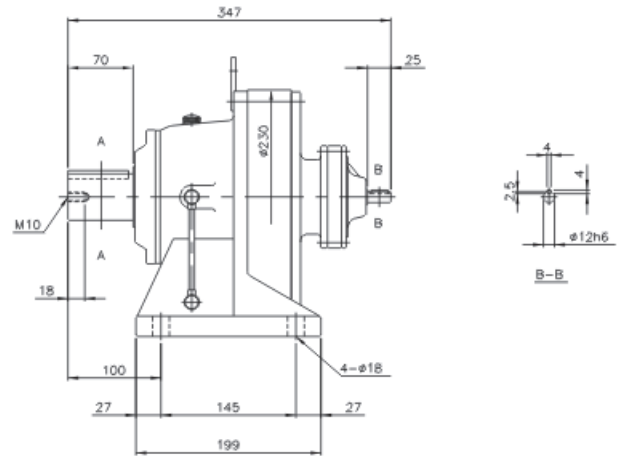
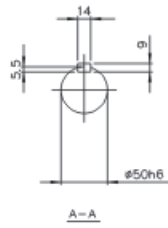
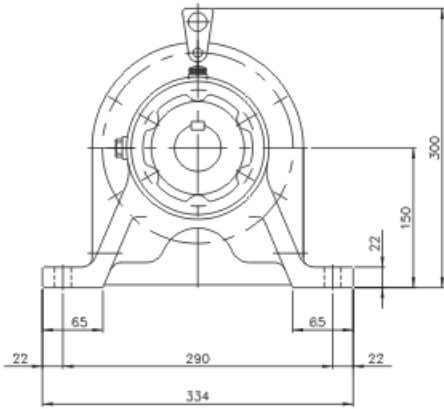

THH-613/09 Weight 46kg,101 lbs

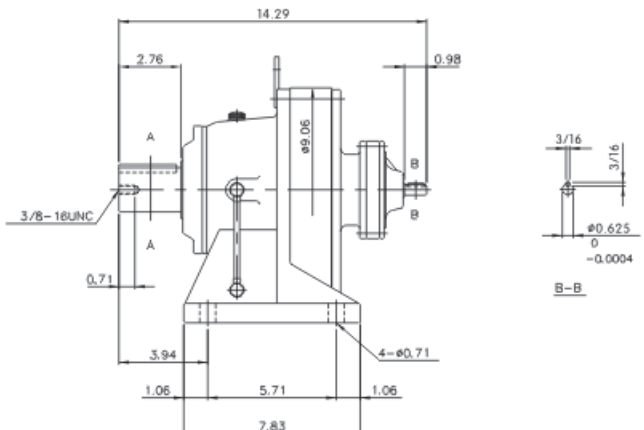
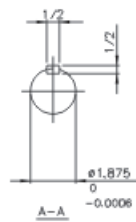
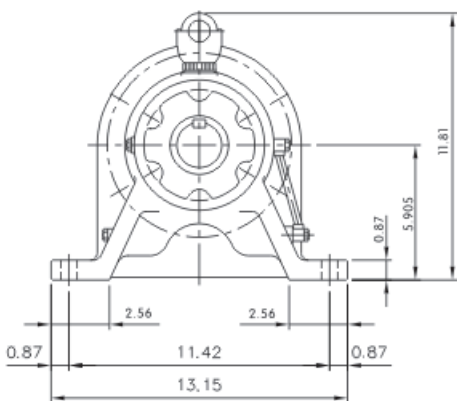
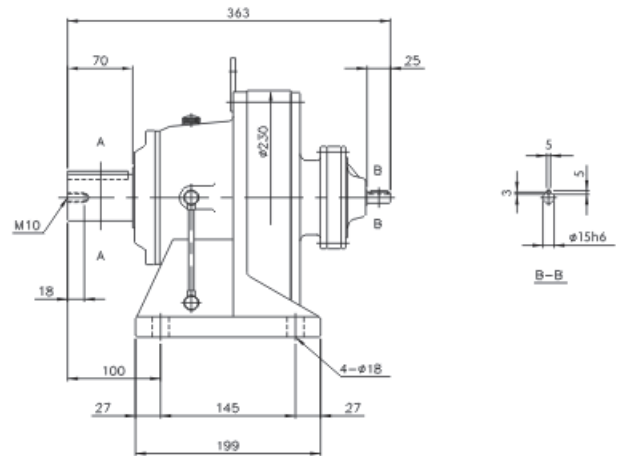
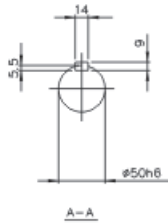
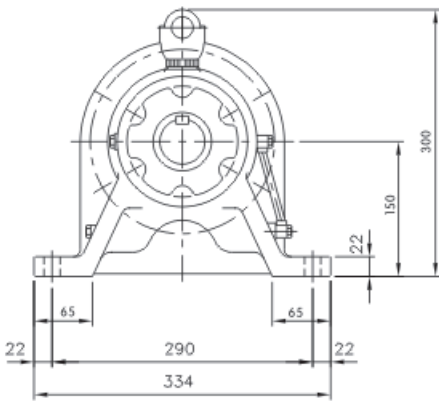



THH-613/10 Weight 46kg,101 lbs

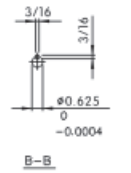
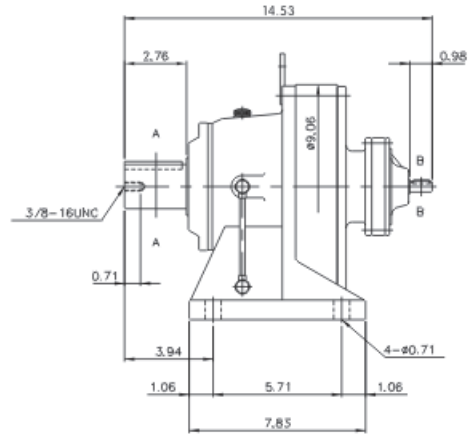
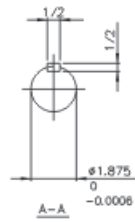
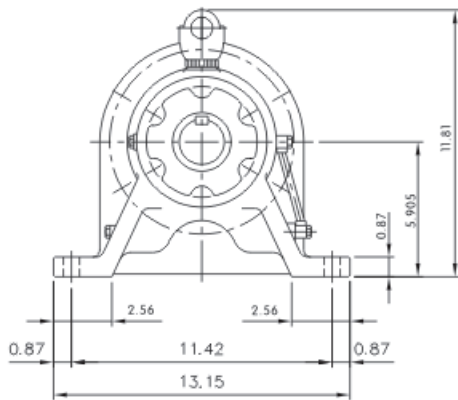
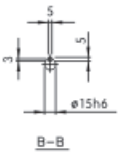
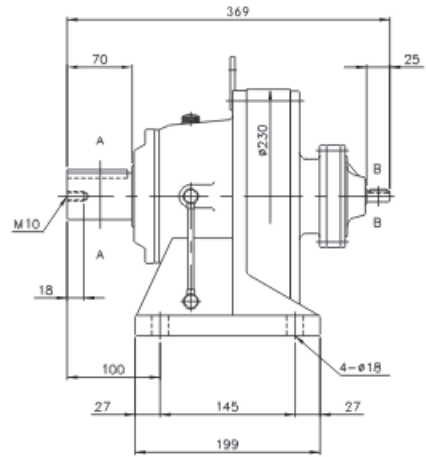
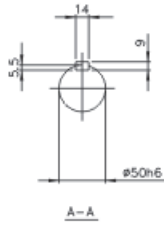
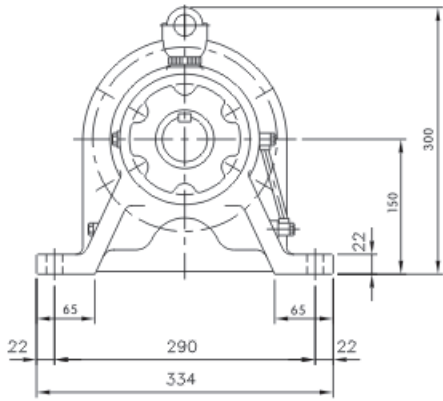

TH-614/08 Weight 41kg,90 lbs

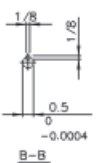
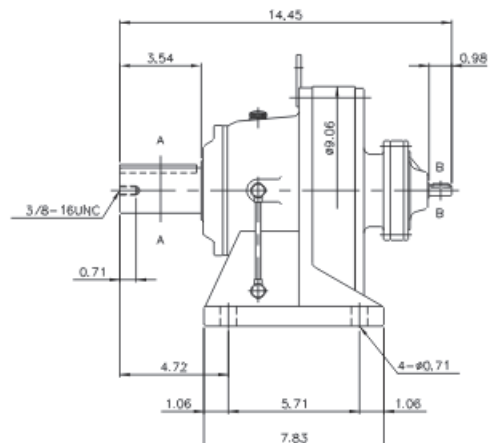
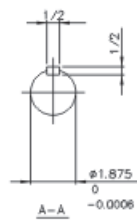
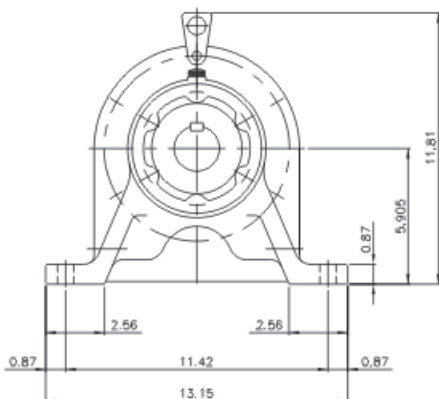
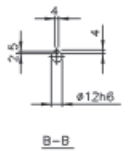
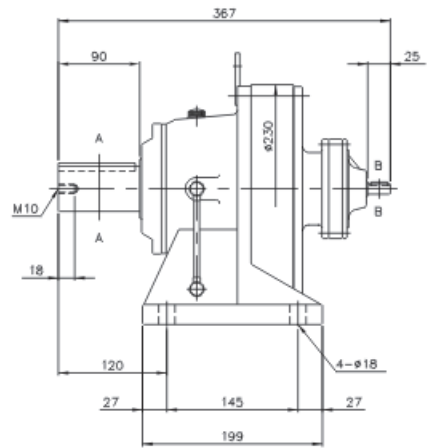
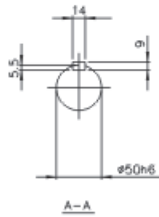
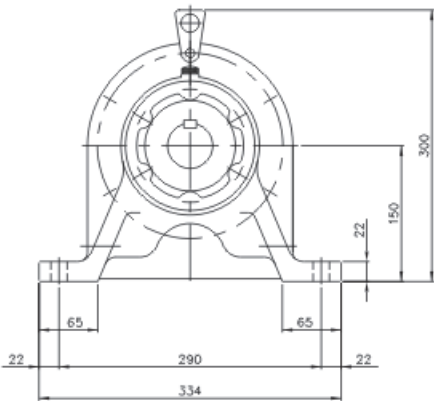

TH-614/09 Weight 46kg,101 lbs

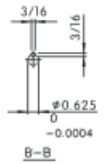
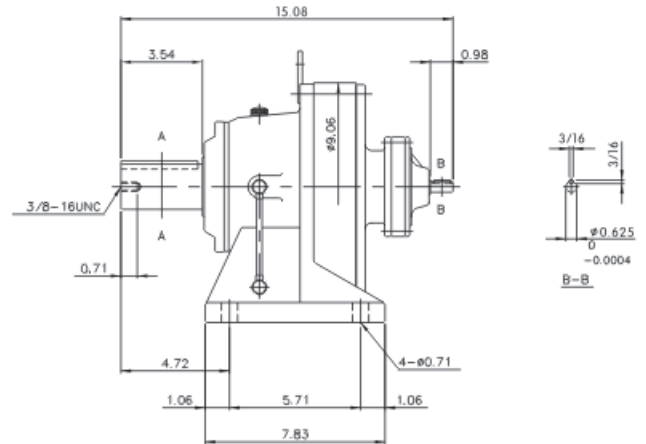
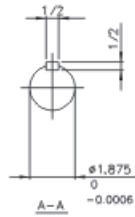
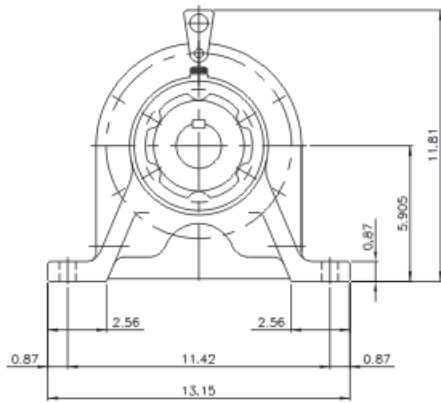
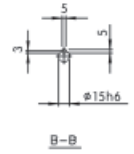
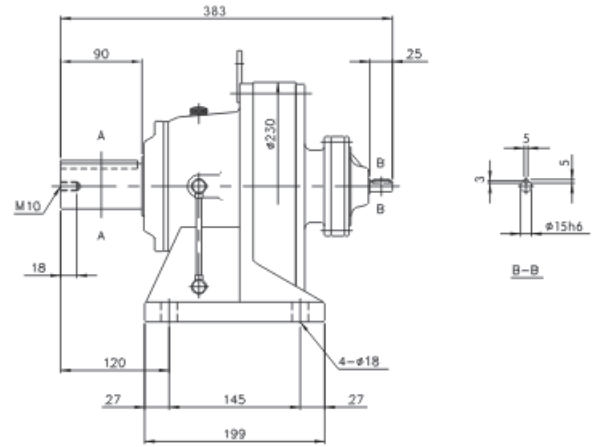
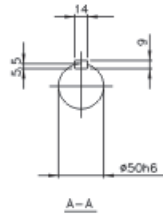
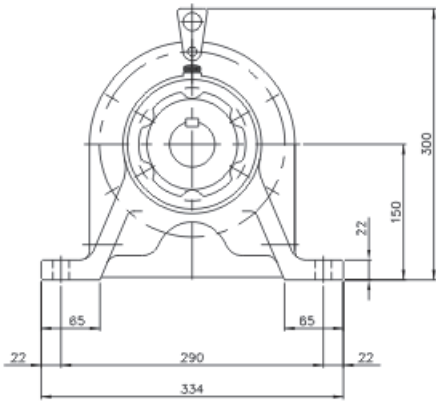

TH-614/10 Weight 46kg,101 lbs

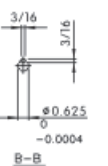
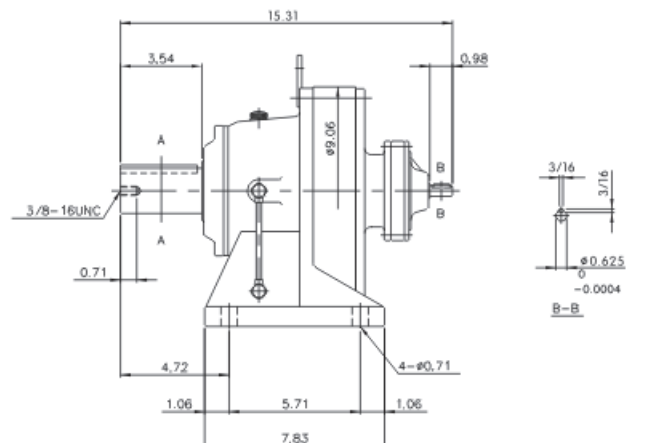
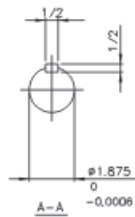
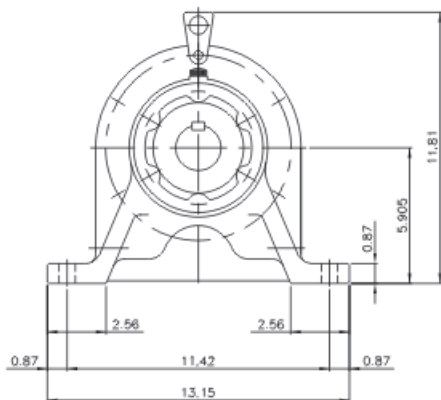
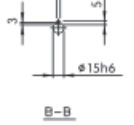
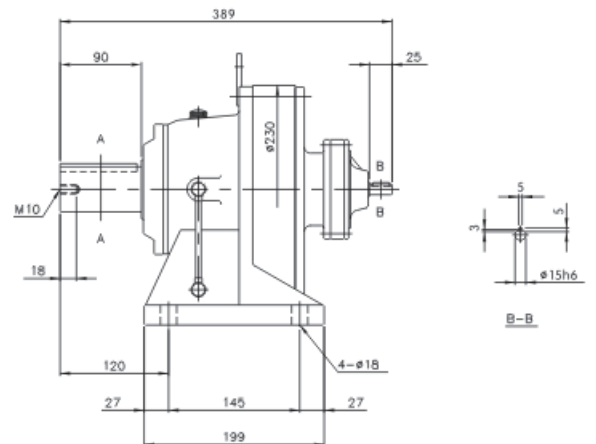
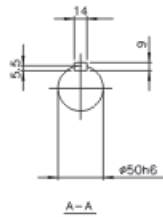
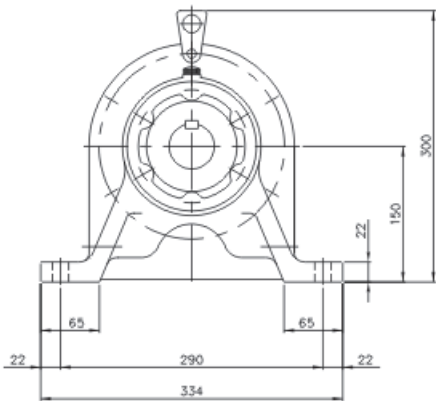

THH-616/09 Weight 86kg,189 lbs

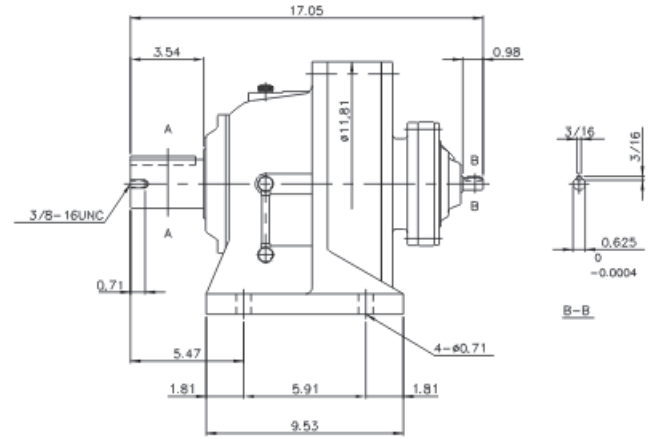
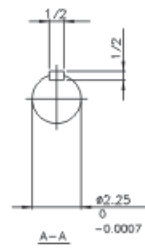
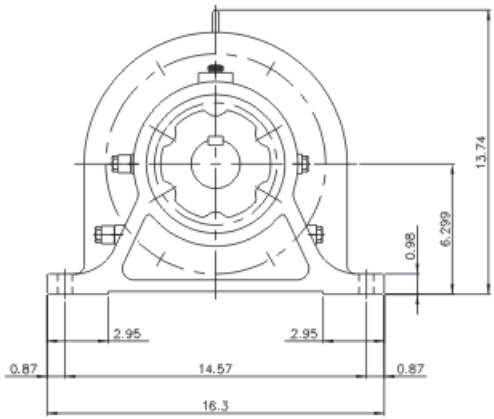
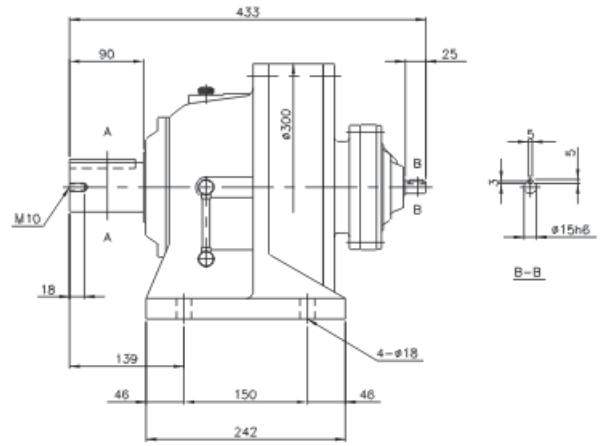
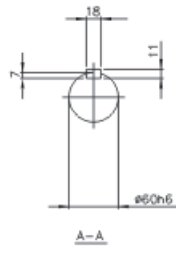
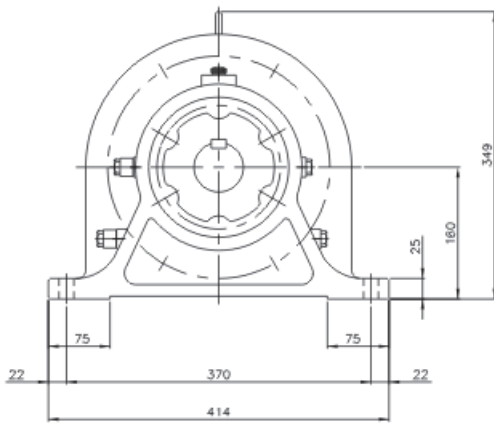

THH-616/09 Weight 86kg,189 lbs

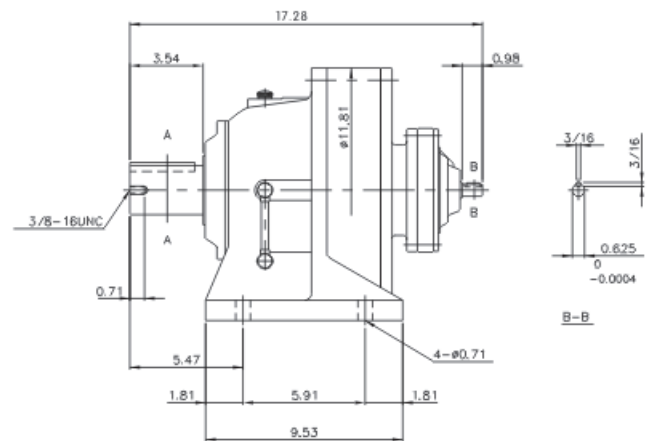
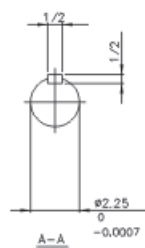
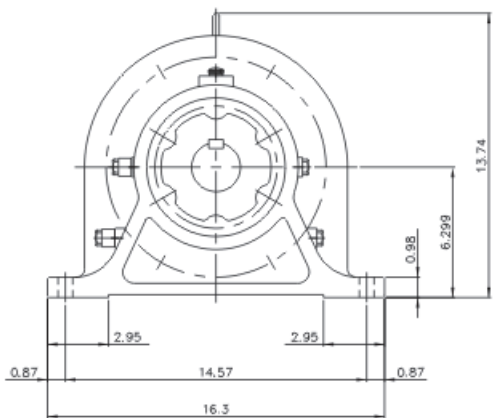
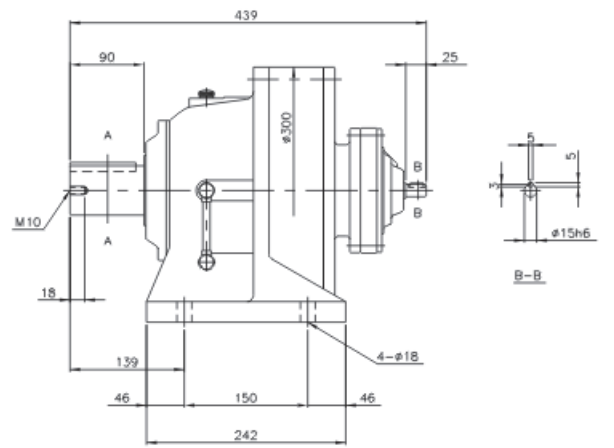
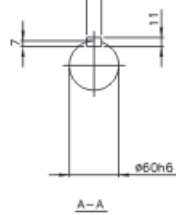
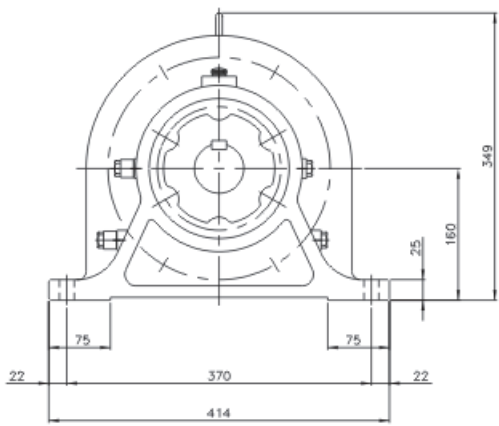



THH-616/11 Weight 95kg,209 lbs

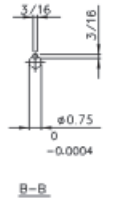
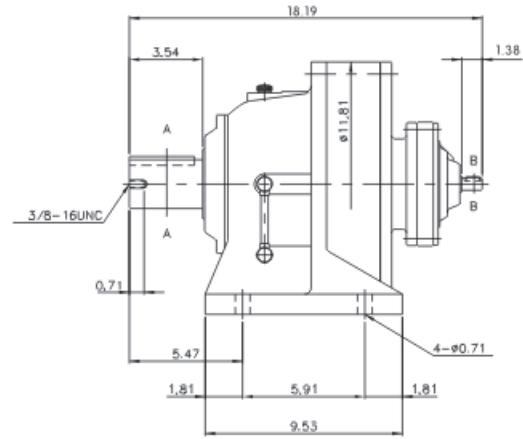
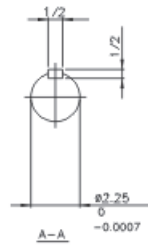
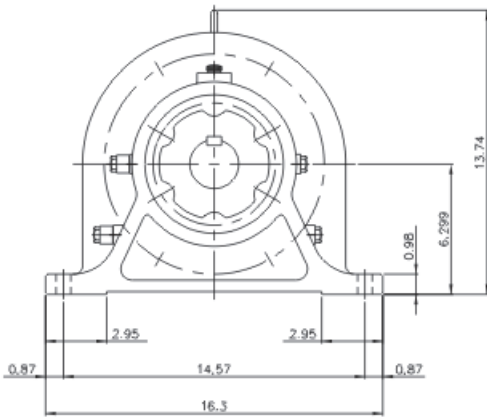
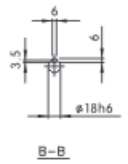
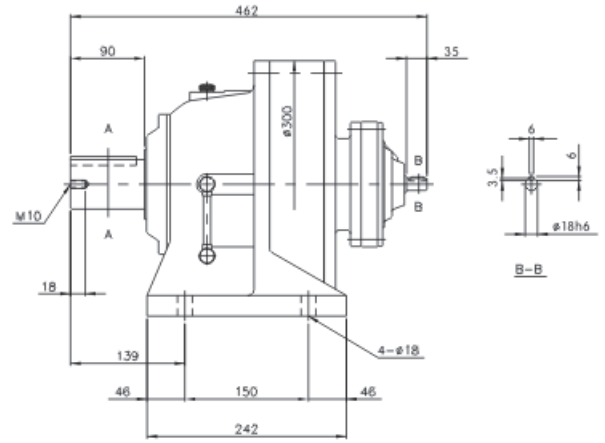
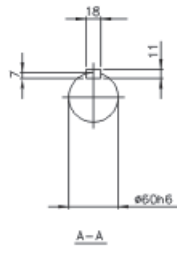
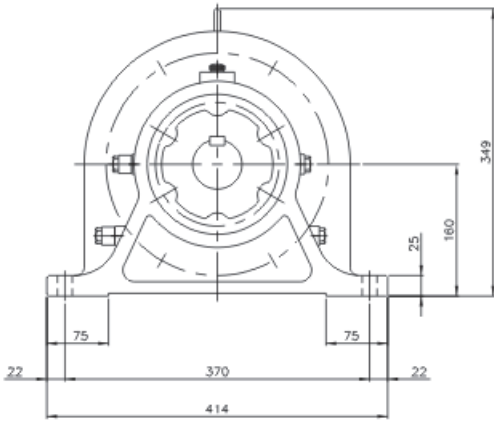

THH-617/09 Weight 120kg,264 lbs

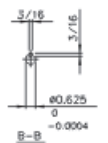
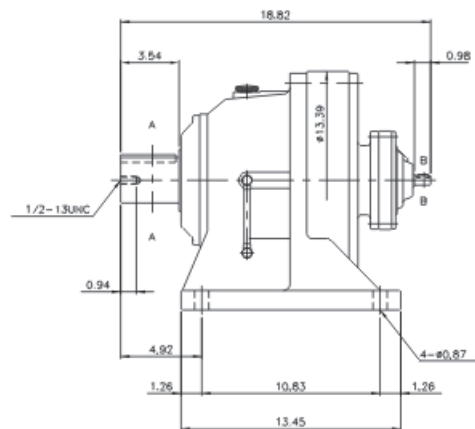
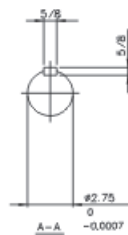
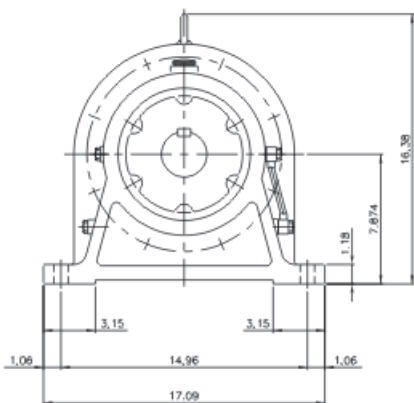
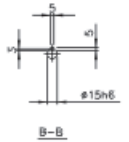
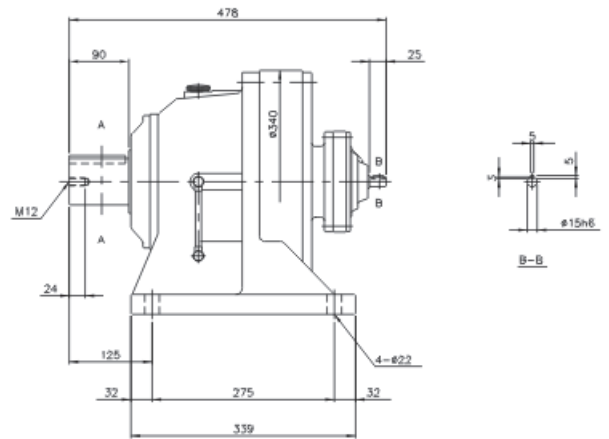
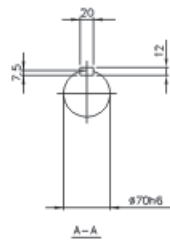
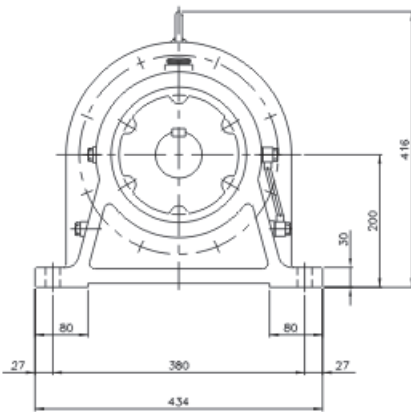

THH-617/10 Weight 125kg,275lbs

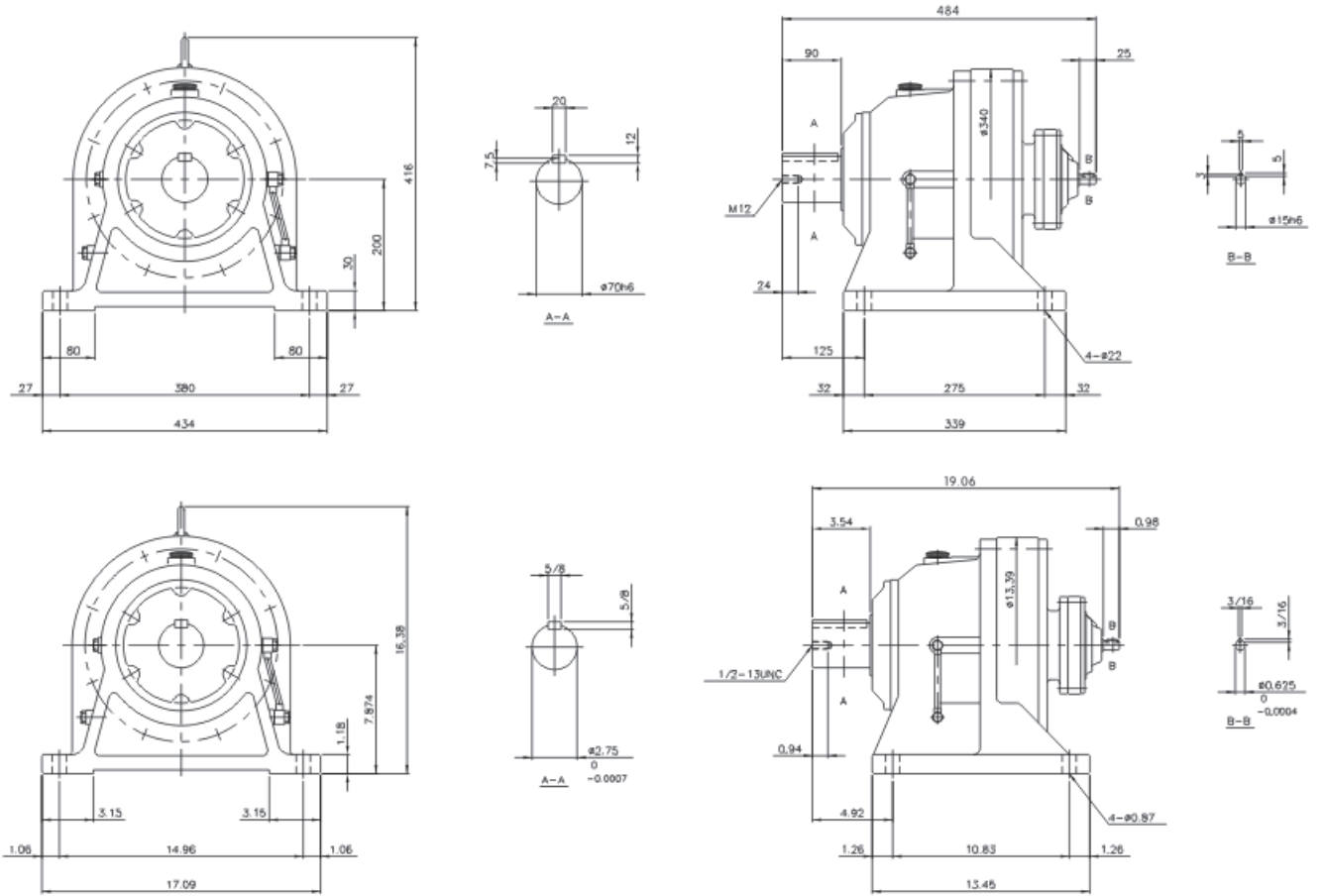

THH-617/11 Weight 130kg,286lbs

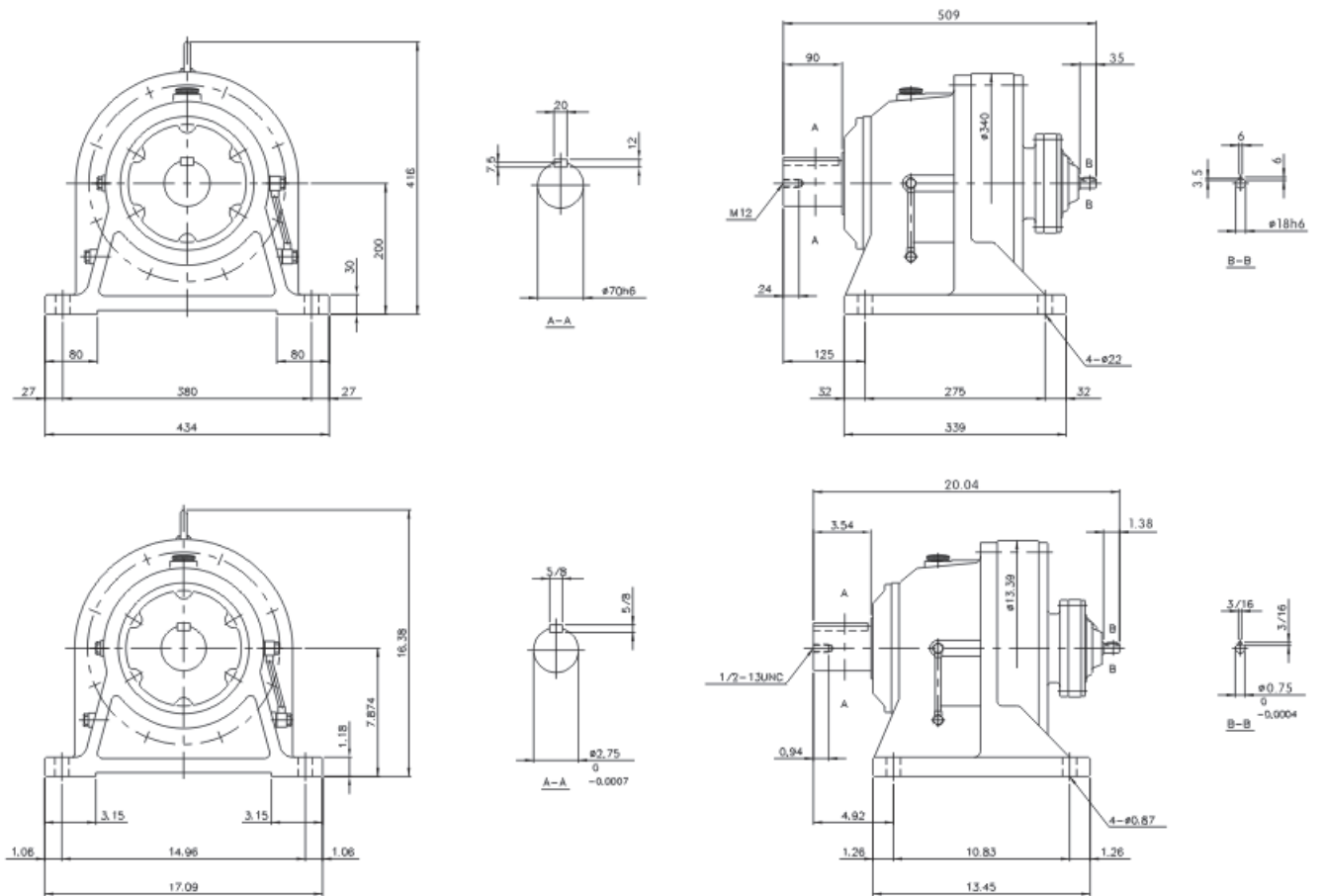

THH-618/10 Weight 166kg,365 lbs

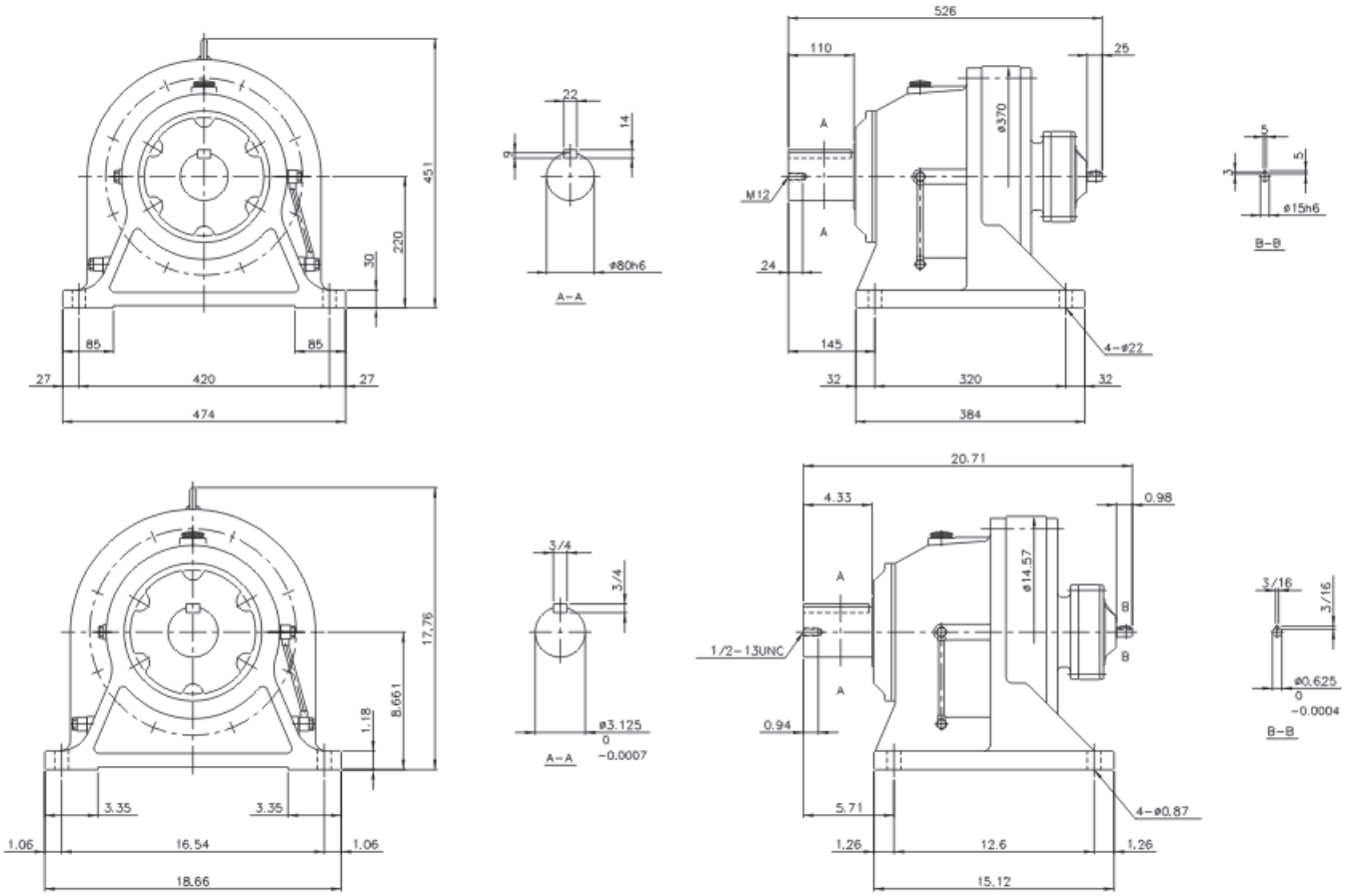

THH-618/13 Weight 185kg,407 lbs

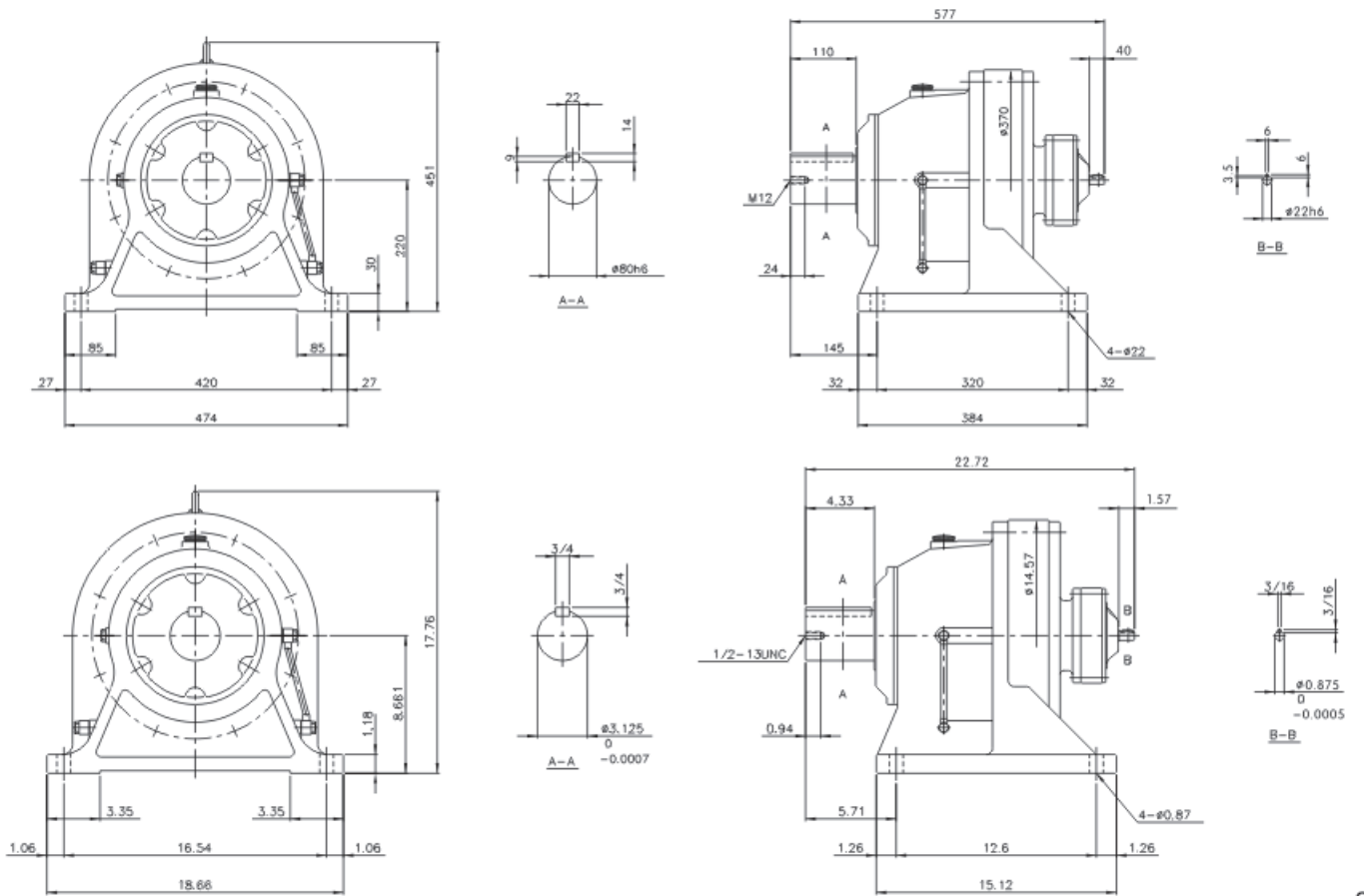



THH-619/11 Weight 240kg,528 lbs

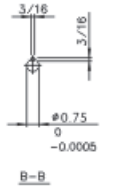
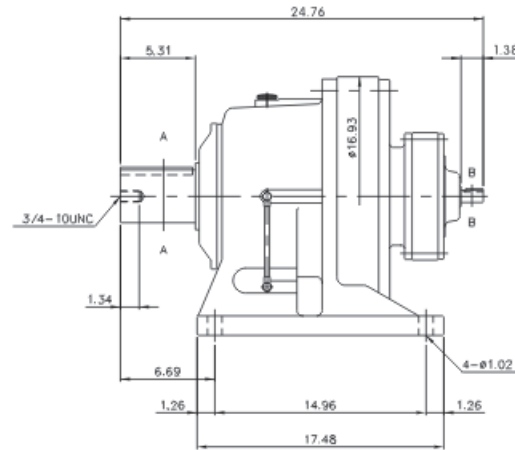
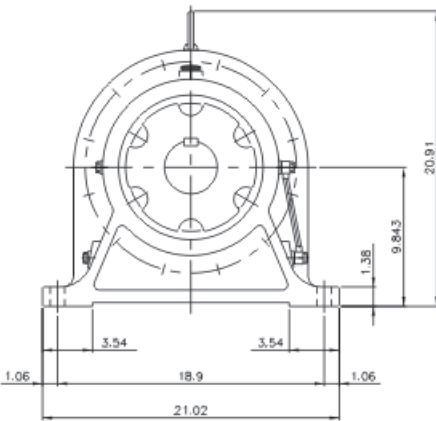
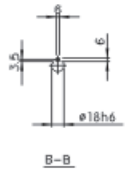
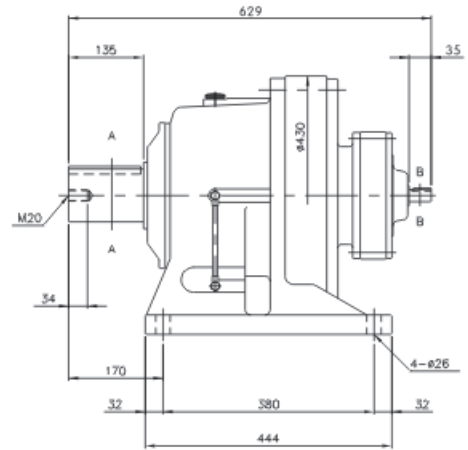
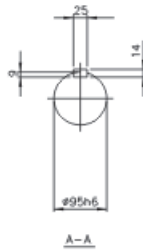
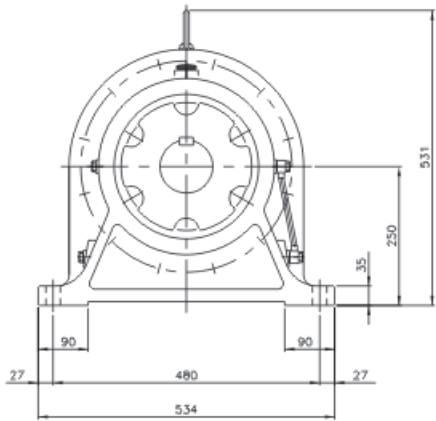

THH-619/13 Weight 250kg,550 lbs

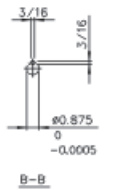
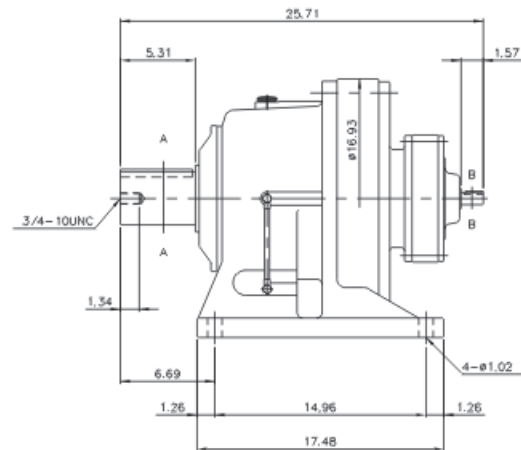
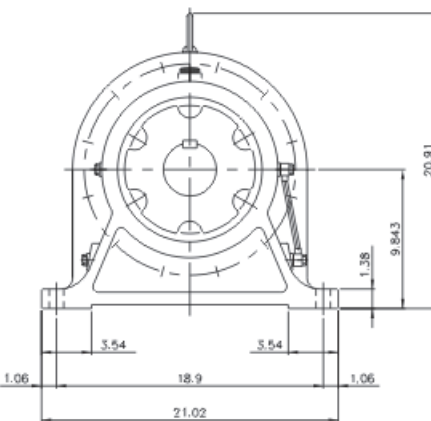
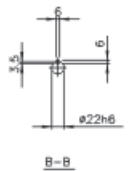
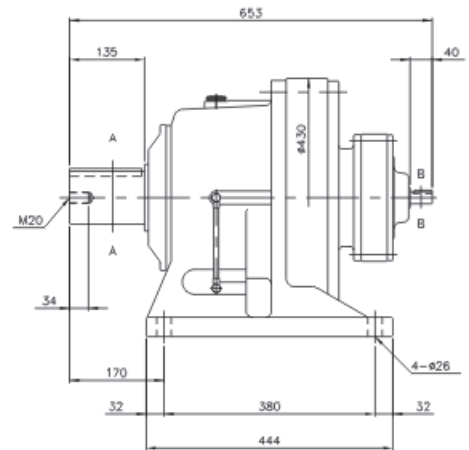
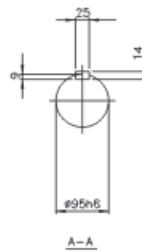
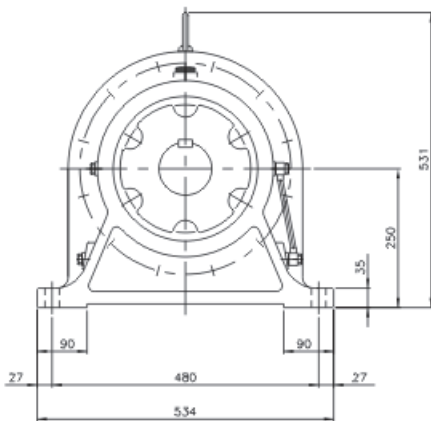

THH-620/11 Weight 261kg,574 lbs

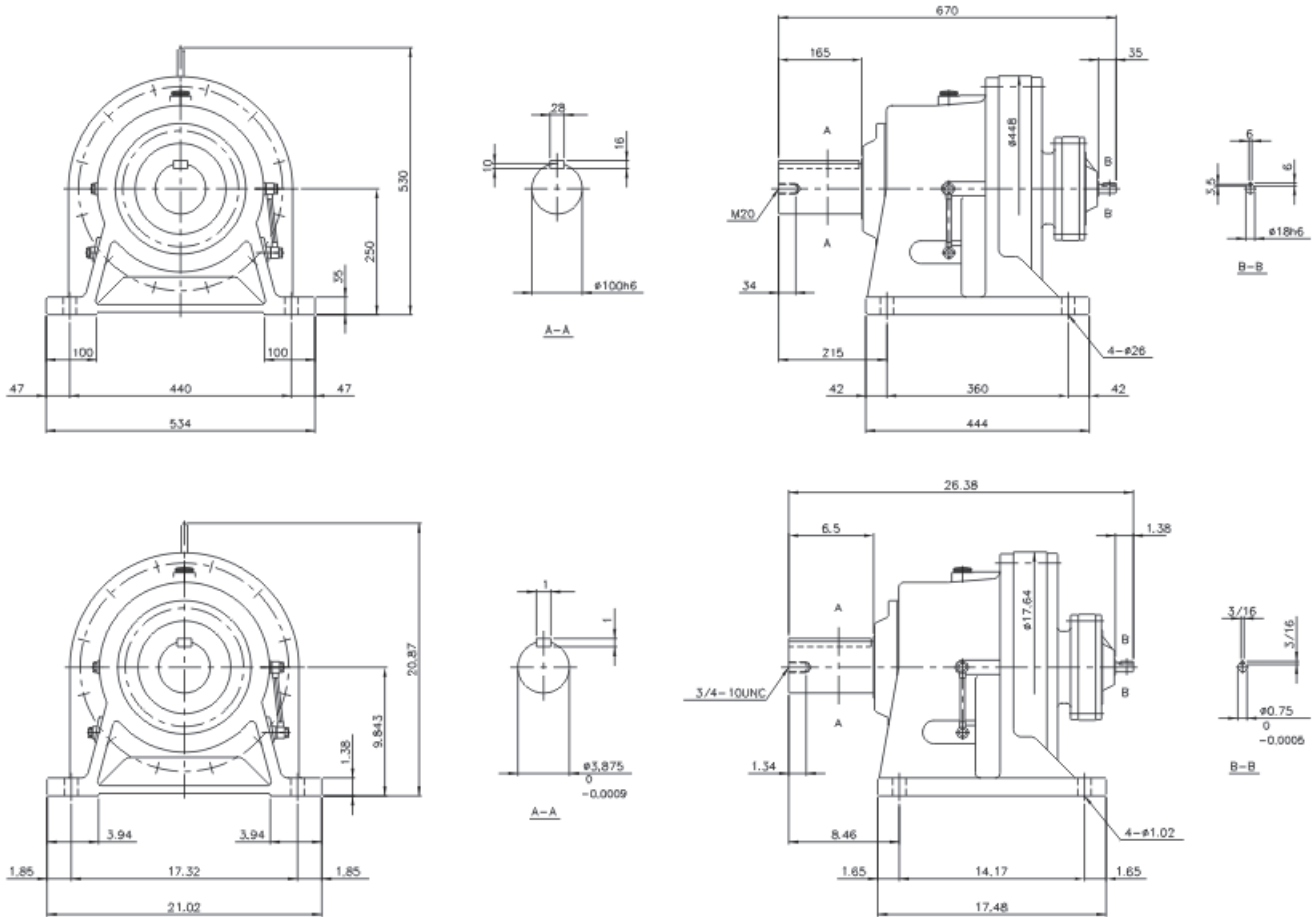

THH-620/13 Weight 275kg,605 lbs

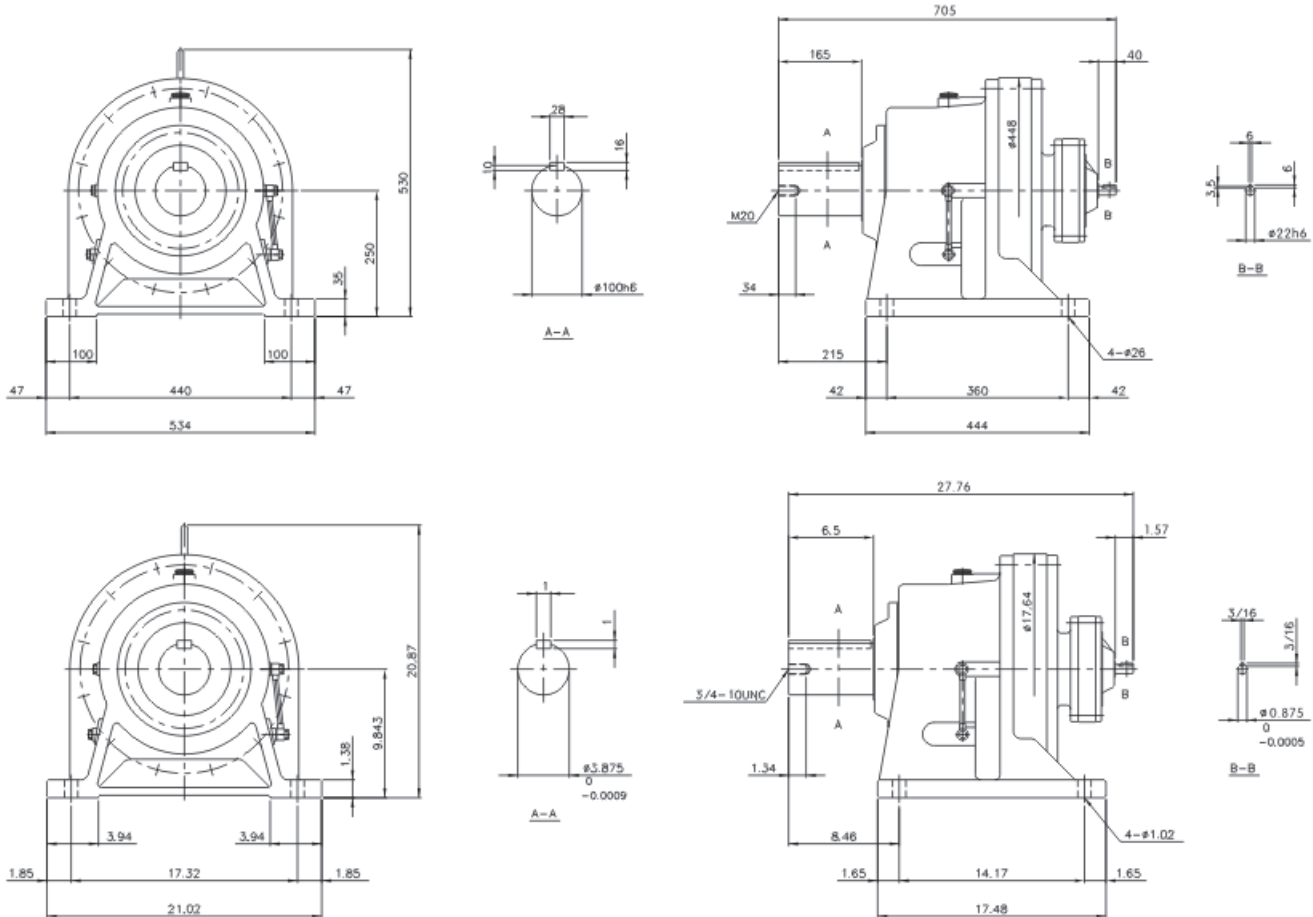

THH-621/13 Weight 355kg,781 lbs

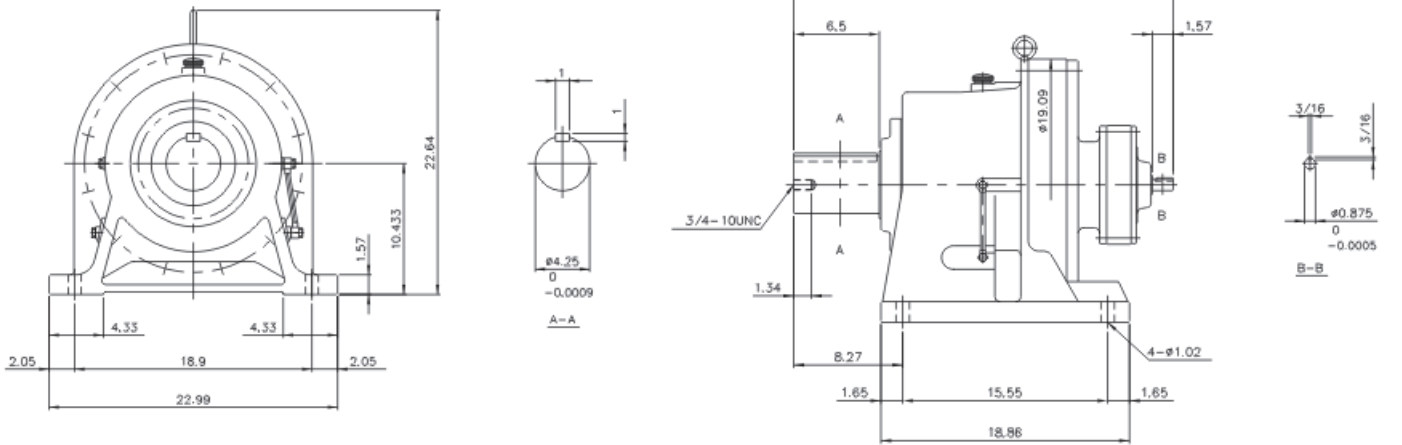
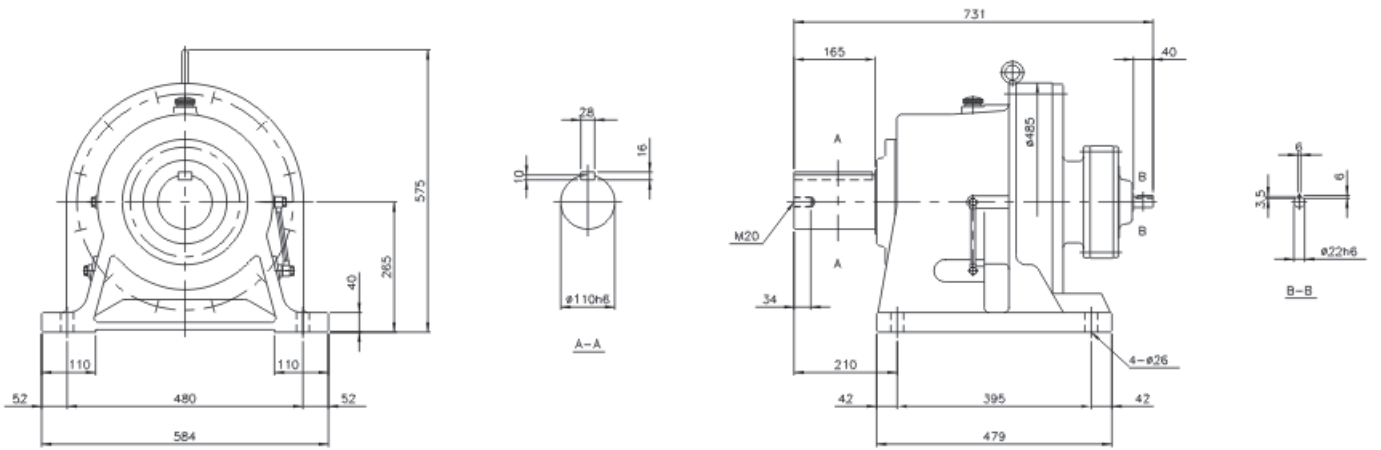

THH-621/16 Weight 375kg,825lbs

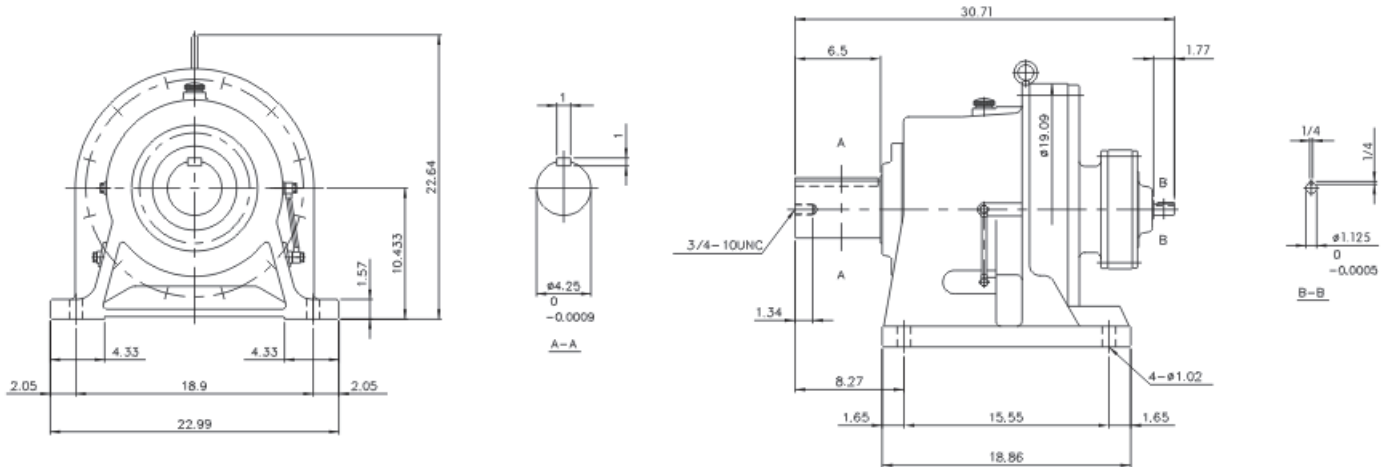
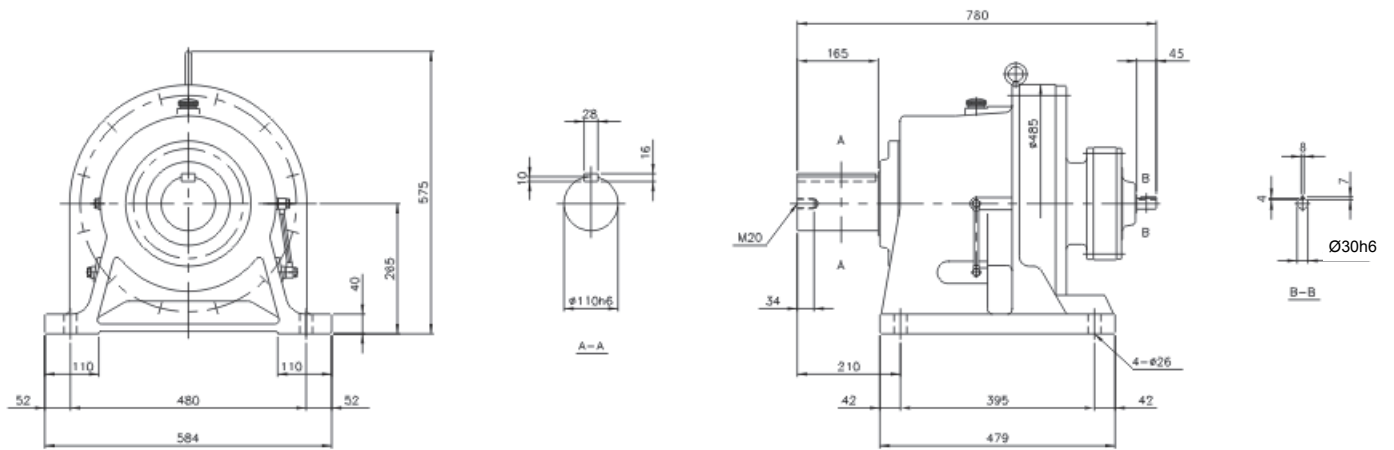



THH-622/13 Weight 430kg,946lbs

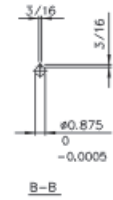
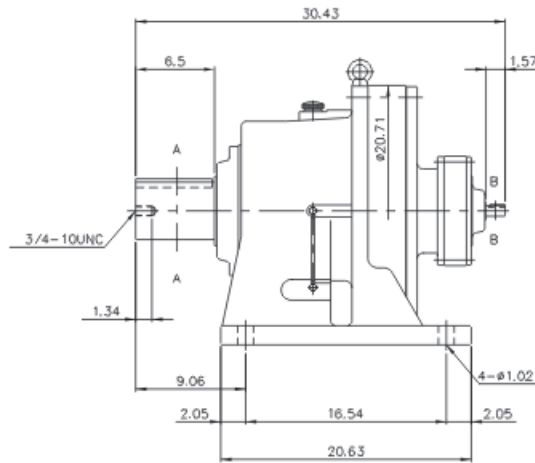
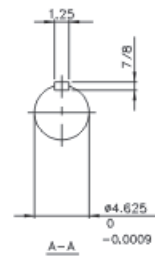
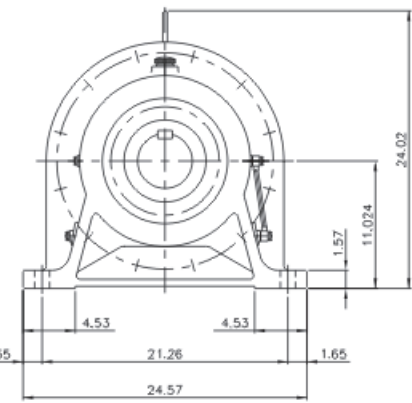
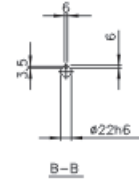
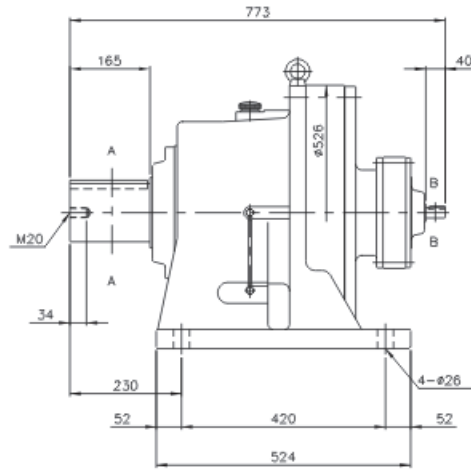
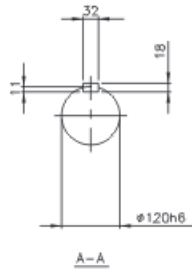
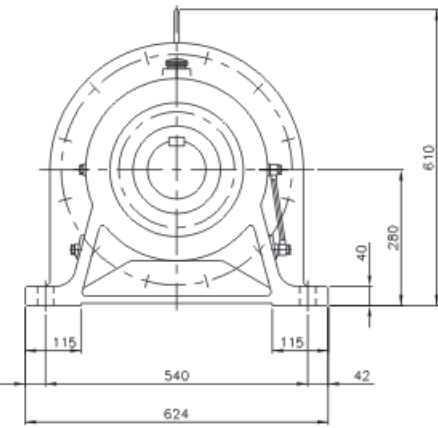

THH-622/17 Weight 475kg,1045 lbs

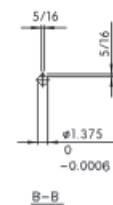
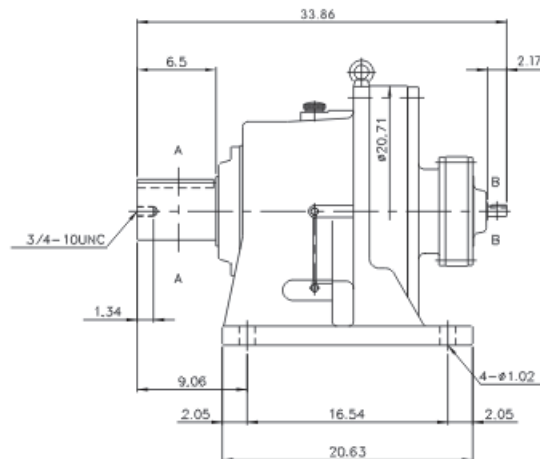
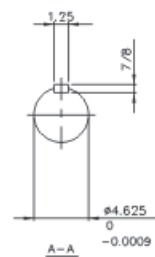
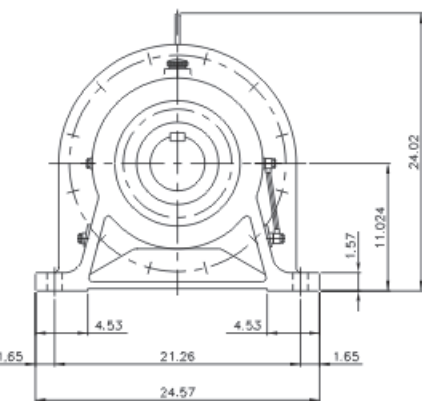
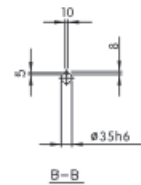
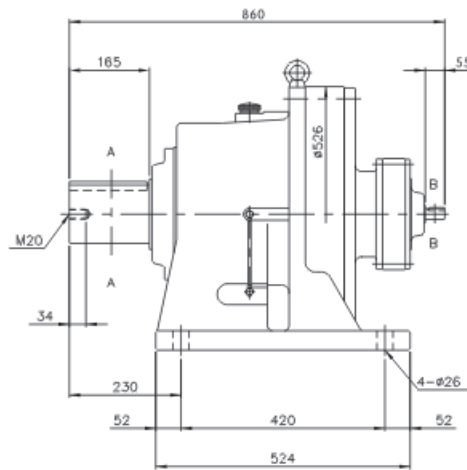
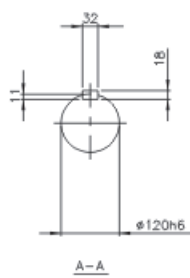
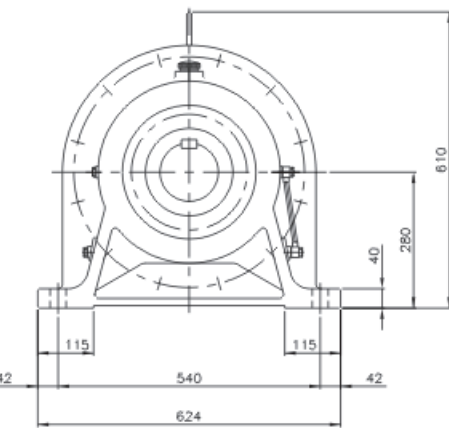



THH-624/16 Weight 655kg,1441 lbs

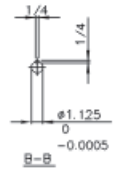
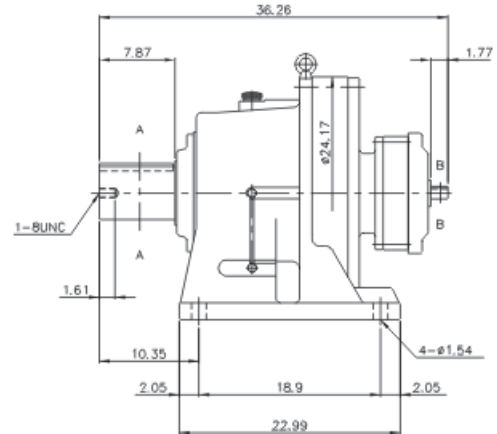
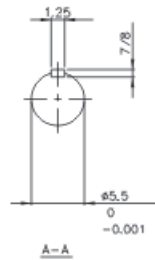
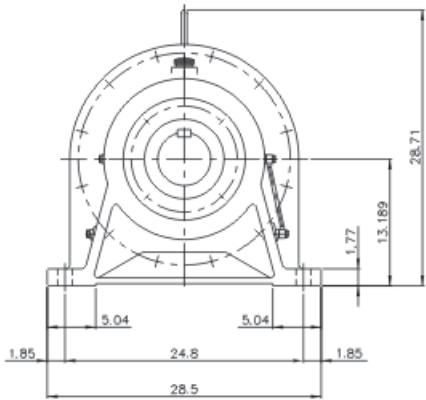
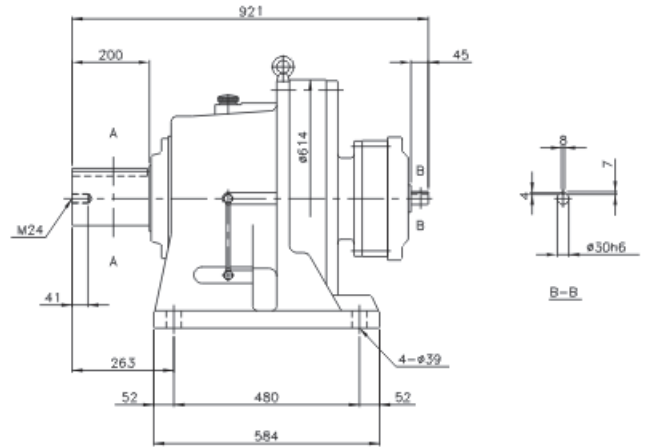
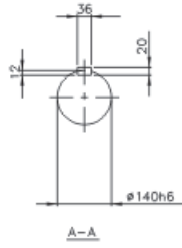
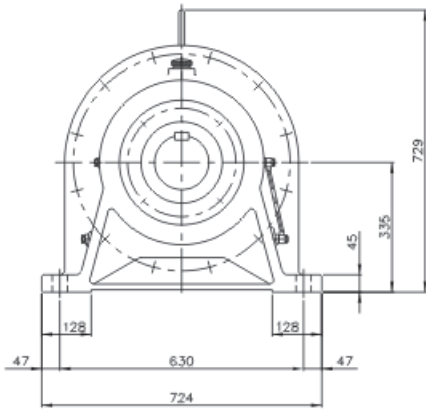

THH-624/18 Weight 688kg,1514 lbs

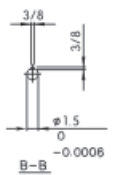
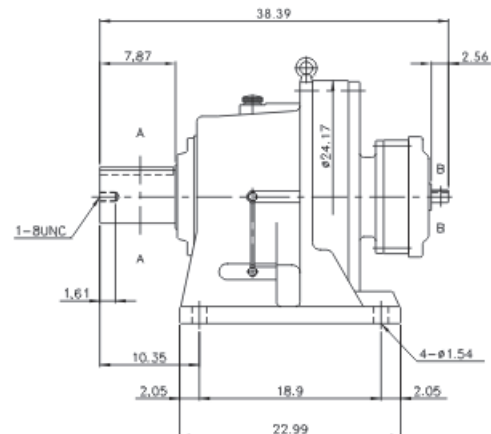
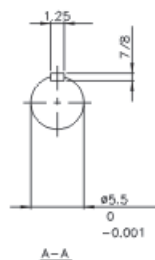
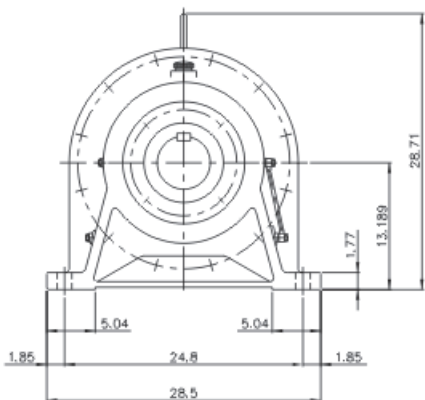
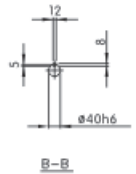
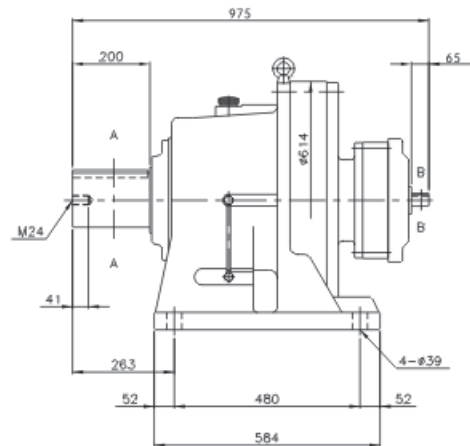
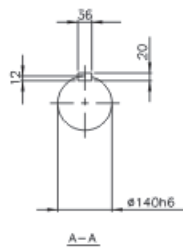
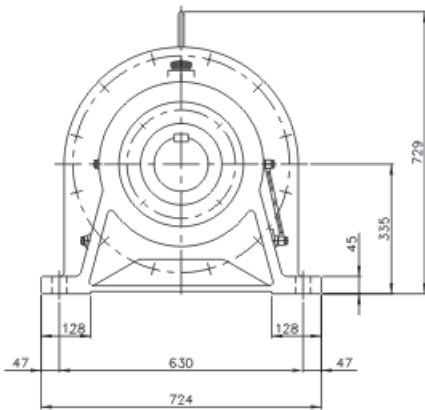



THH-625/17 Weight 1012kg,2226 lbs

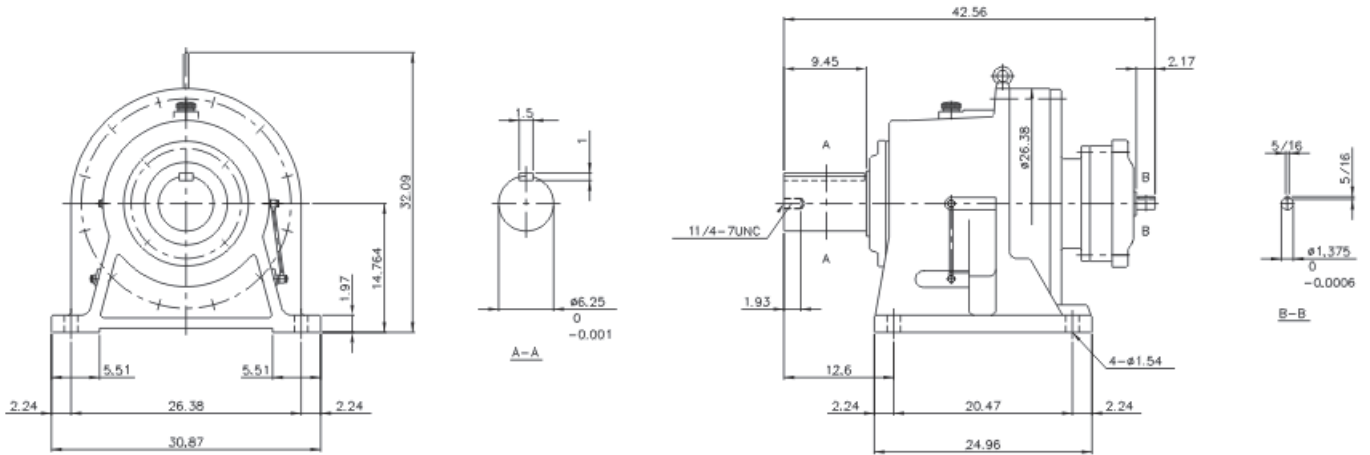
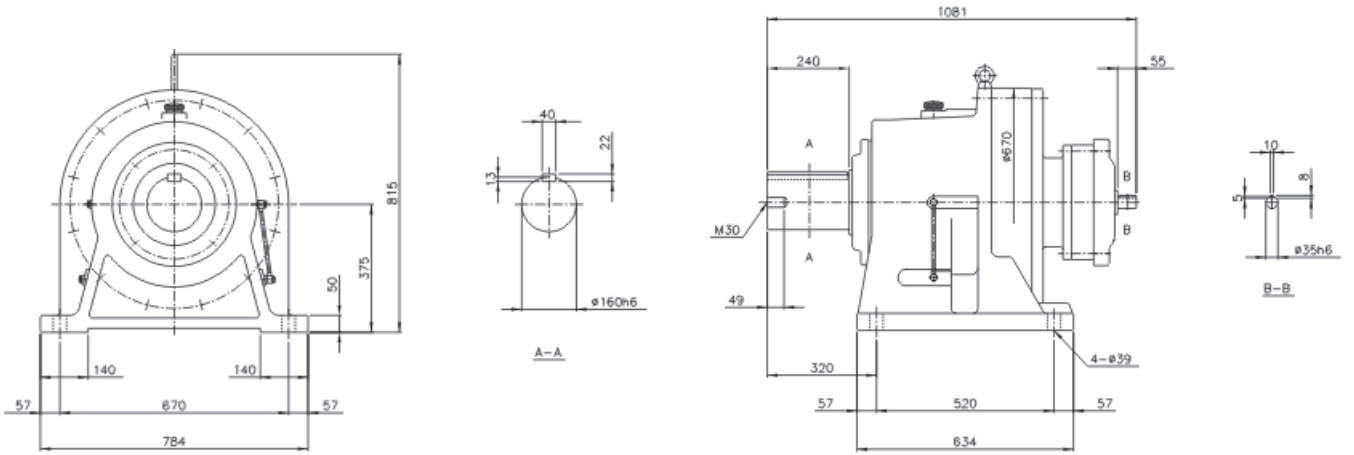

THH-625/19 Weight 1087kg,2391 lbs

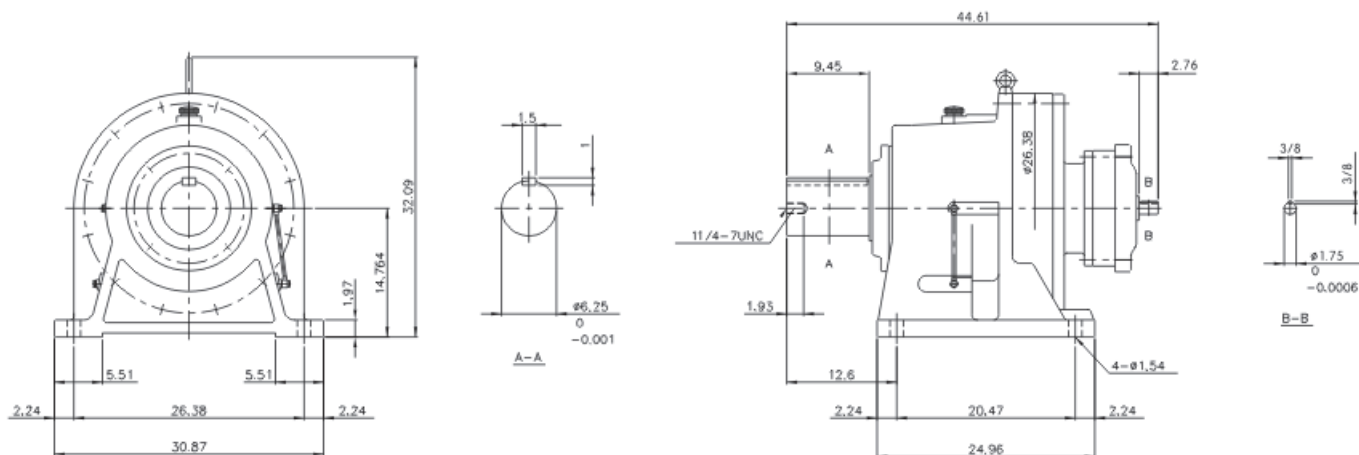
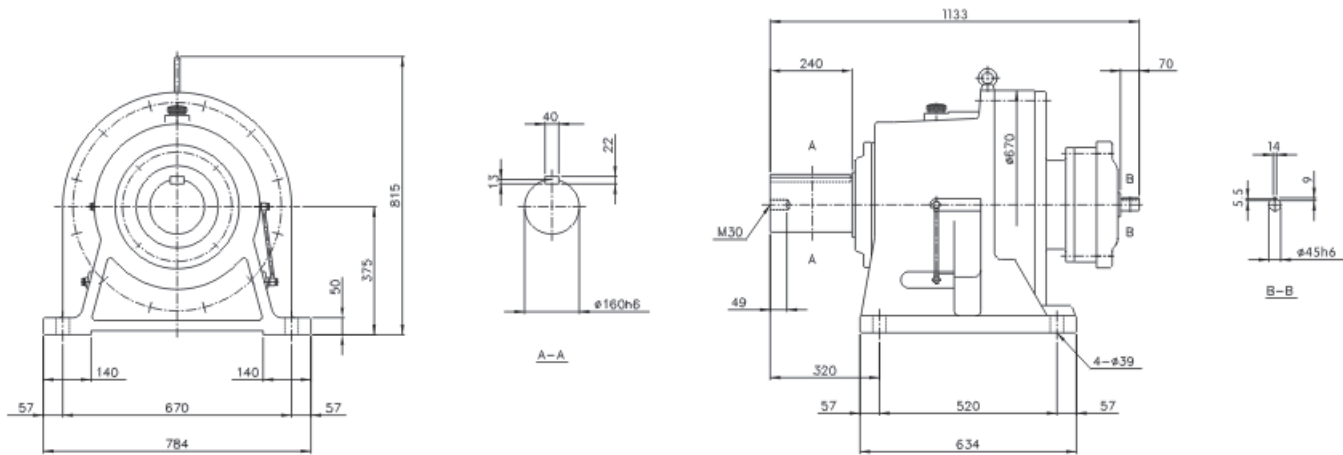

THH-626/19 Weight 1343kg,2955 lbs

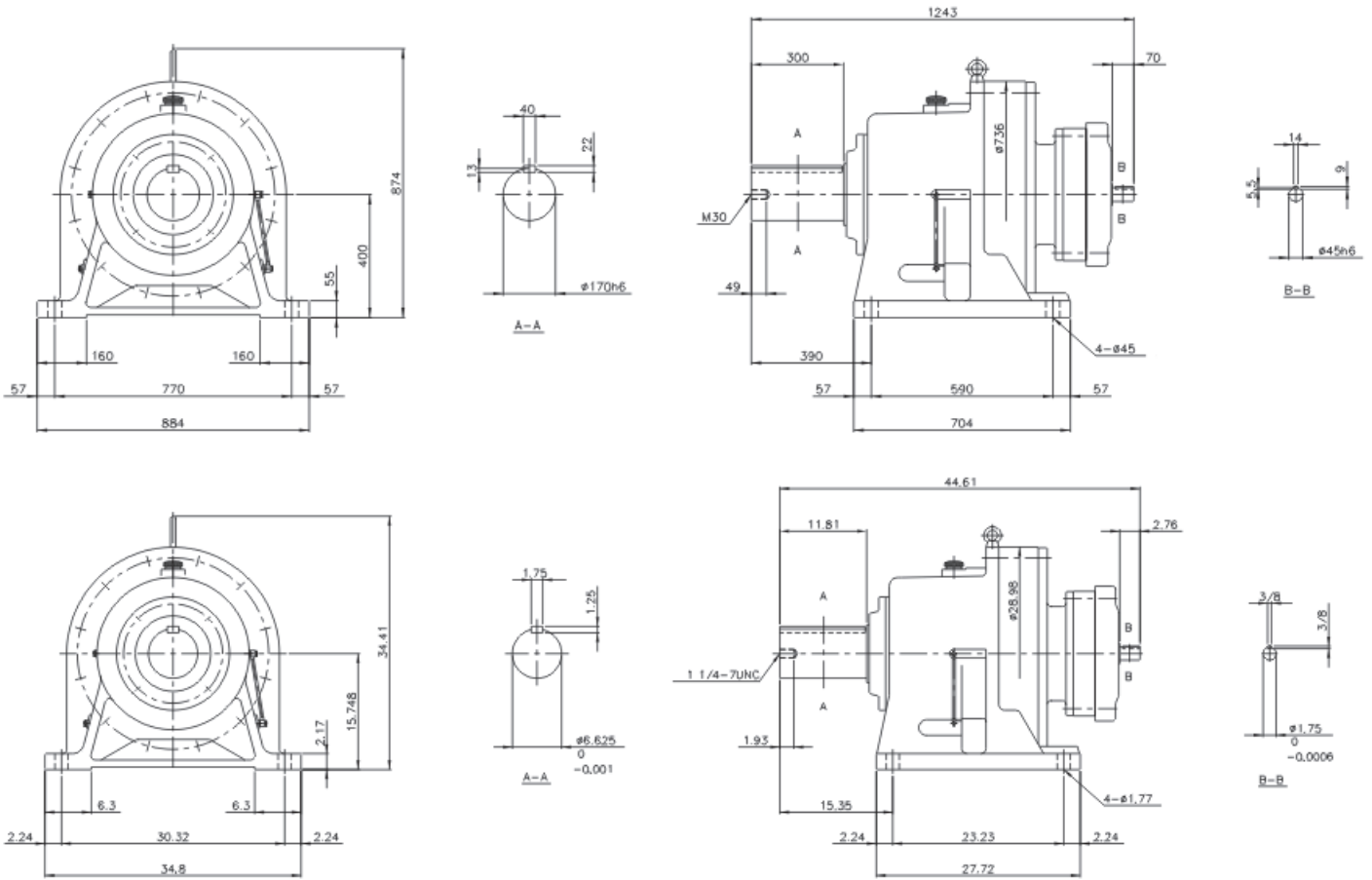

THH-627/19 Weight 2483kg,5463 lbs

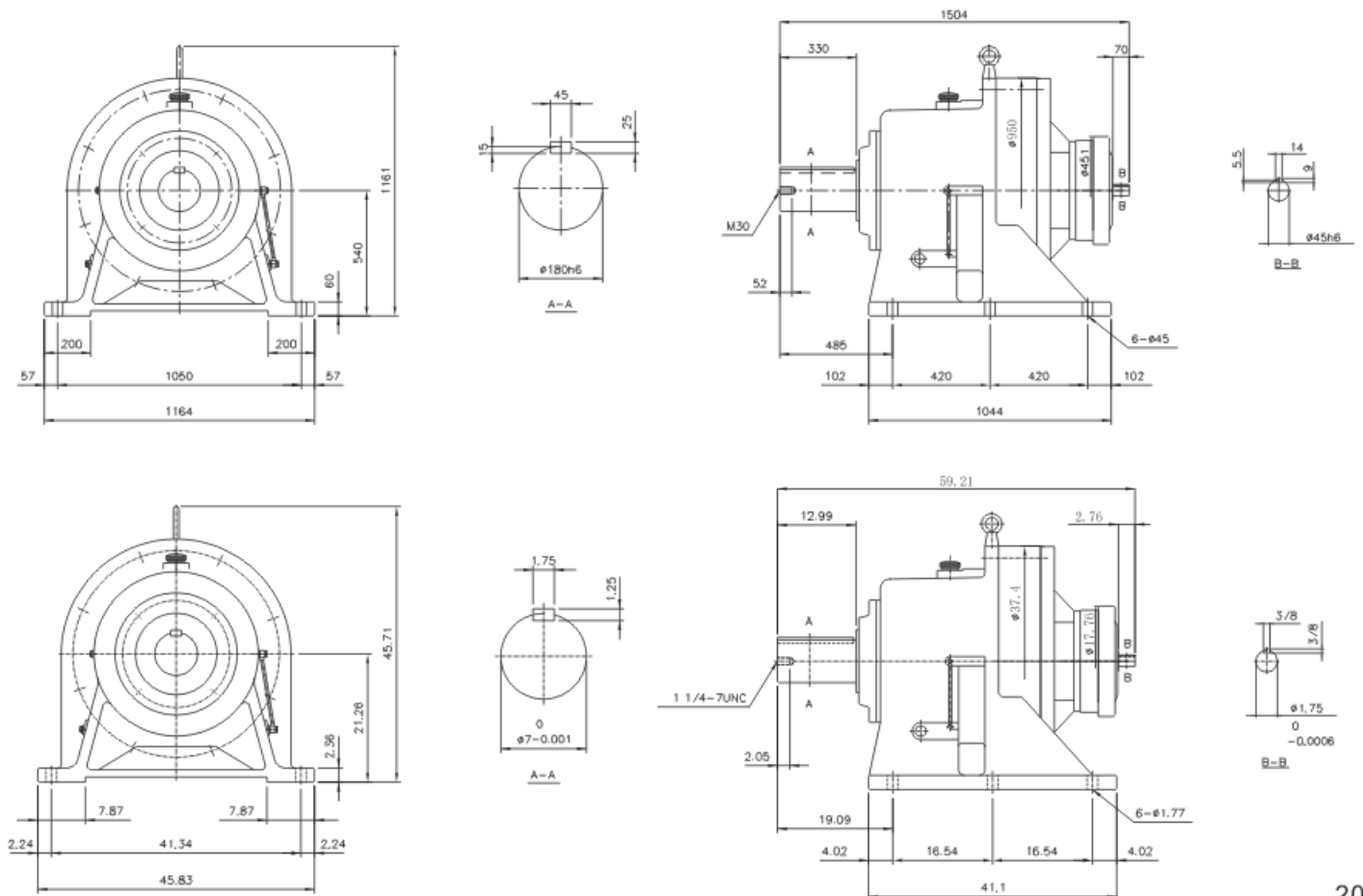

# DIMENSION DRAWINGS

Single Stage Reduction, Vertical TRANSCYKO Speed Reducers

## TV-607

Weight 3.6kg,  
8 lbs

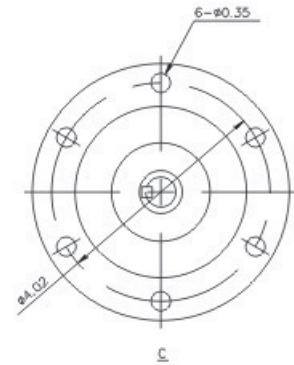
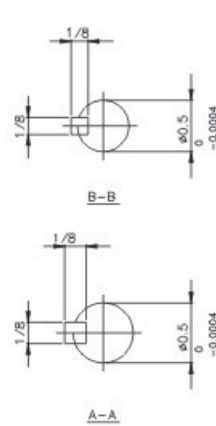
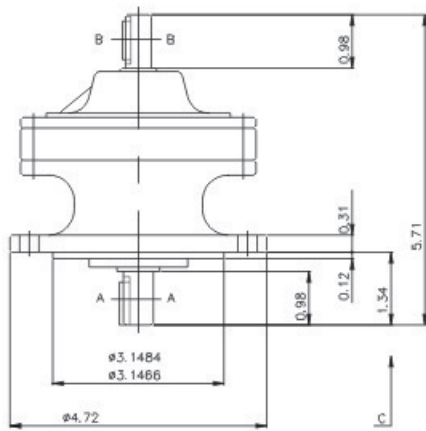
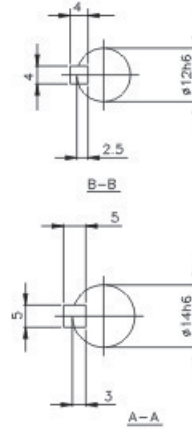
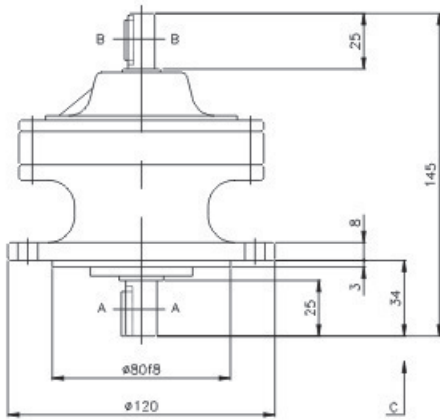

## TV-608

Weight 4.5kg,  
101 lbs

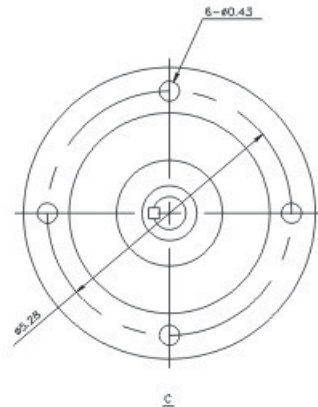
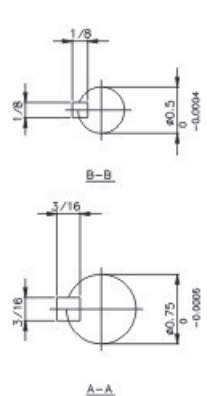
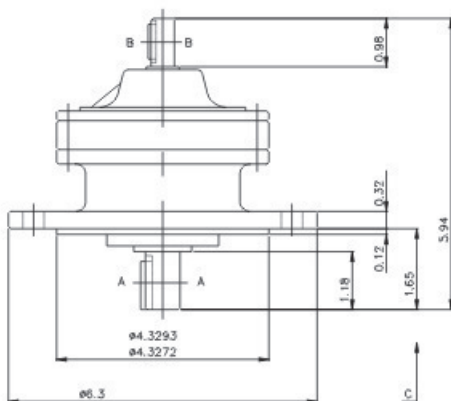
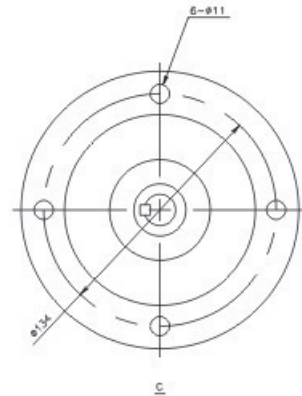
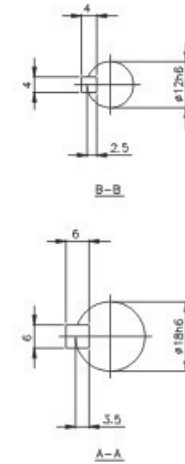
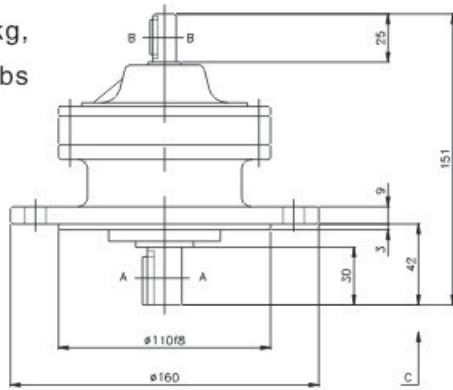



**TV-609**  
Weight 9kg,  
20 lbs

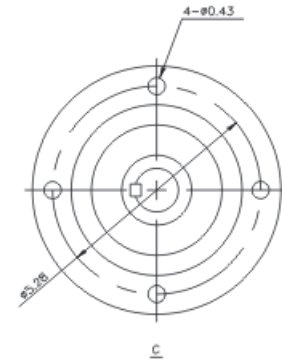
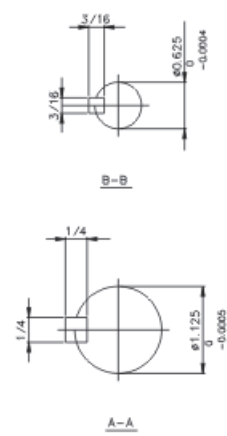
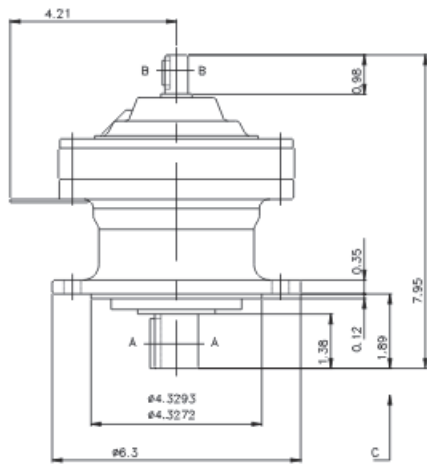
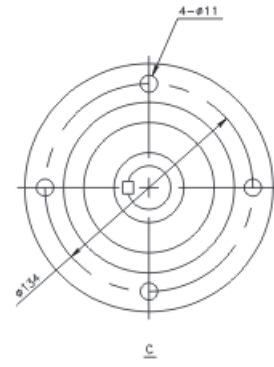
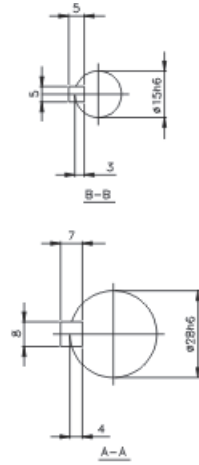
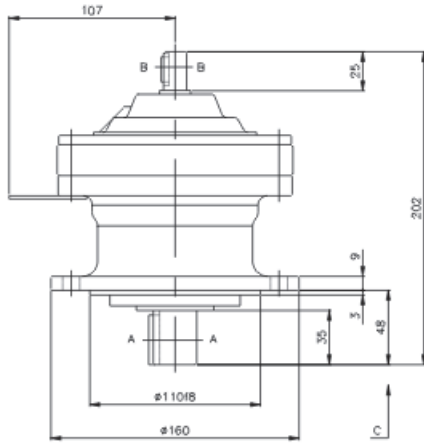

**TV-610**  
Weight 12kg,  
26 lbs

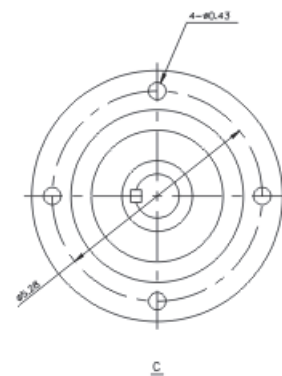
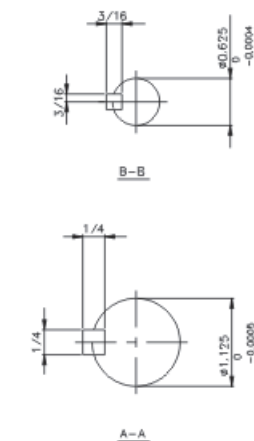
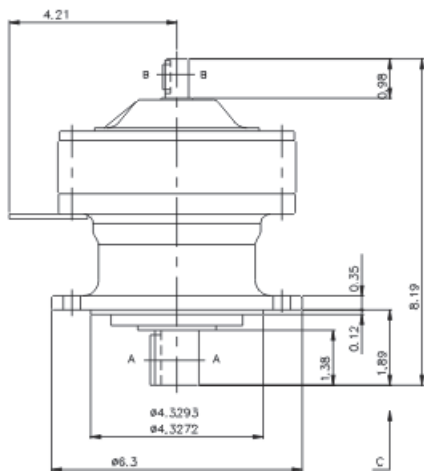
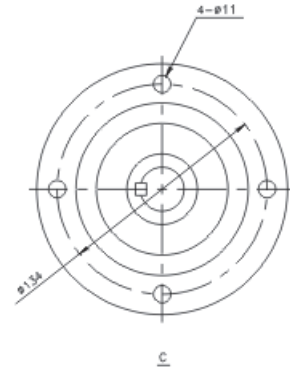
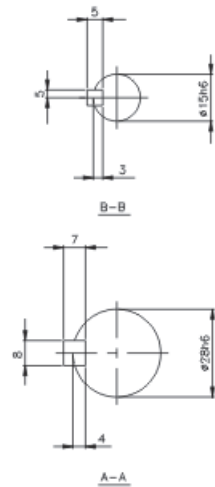
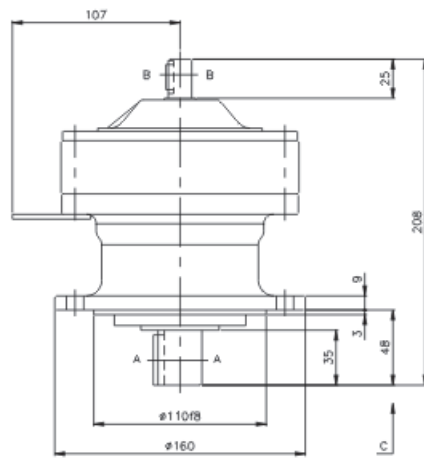

**TV-611**

Weight 24kg,  
53 lbs

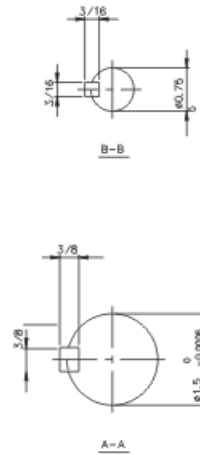
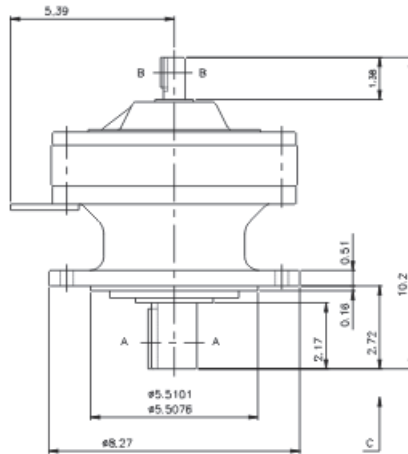
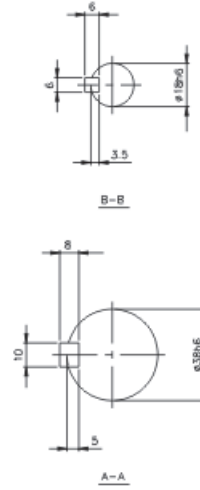
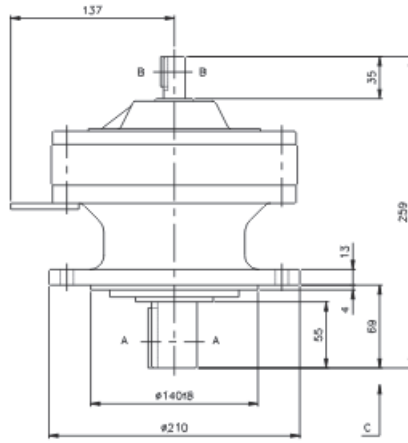

**TV-612**

Weight 24kg,  
53 lbs

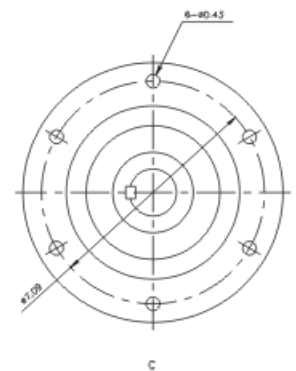
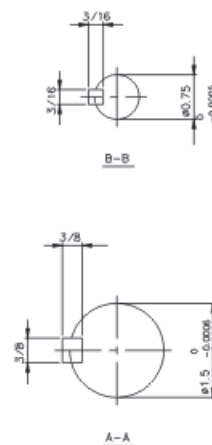
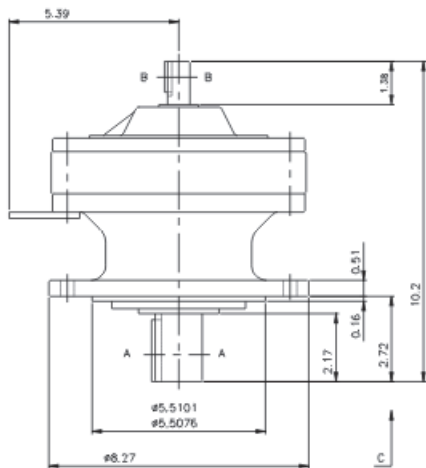
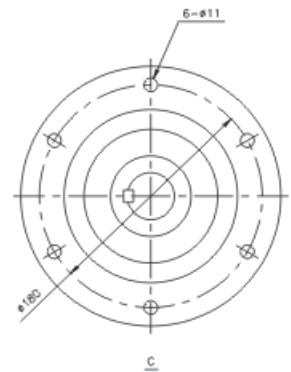
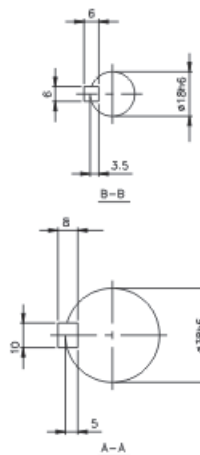
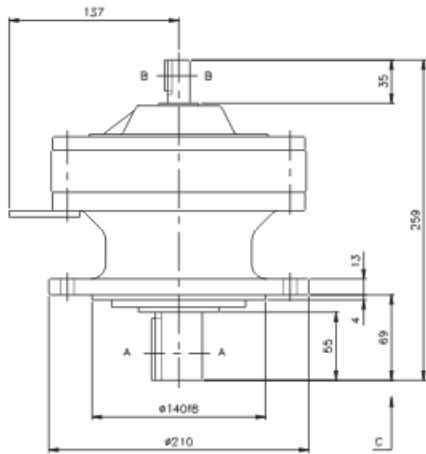

**TDV-613**  
 Weight 43 kg,  
 95 lbs

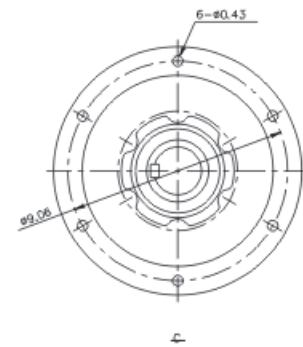
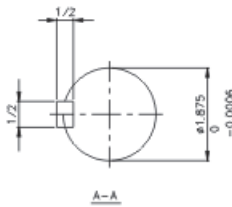
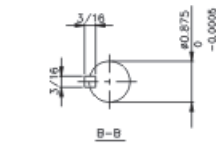
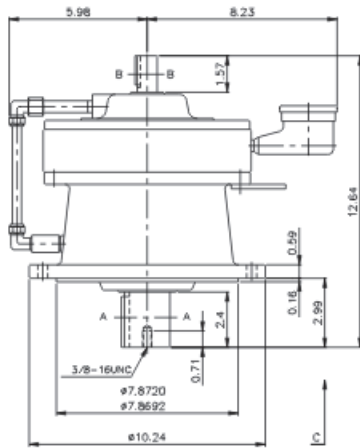
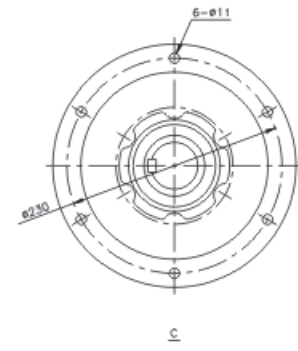
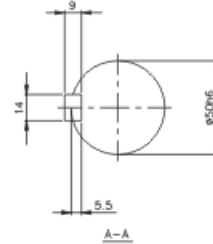
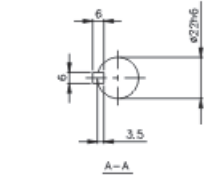
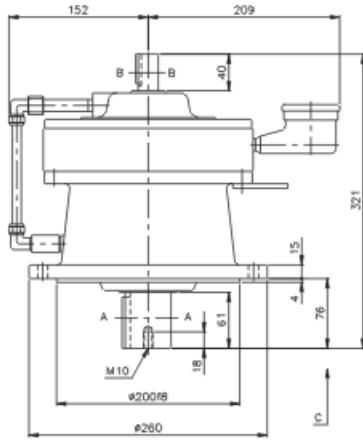

**TDV-614**  
 Weight 43 kg,  
 95 lbs

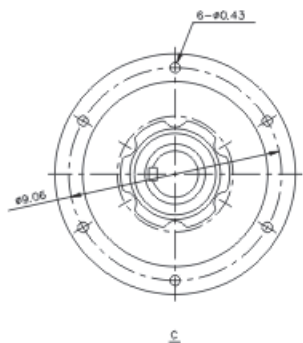
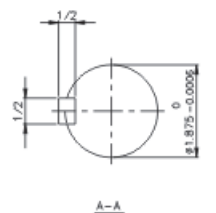
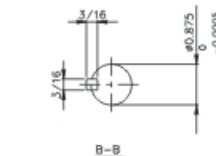
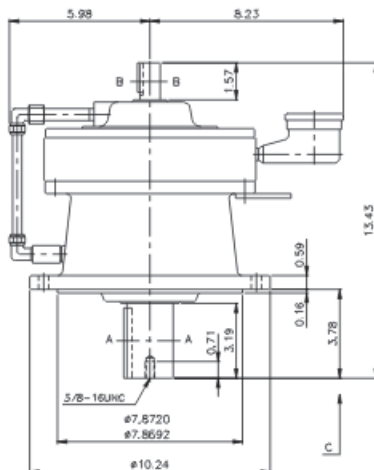
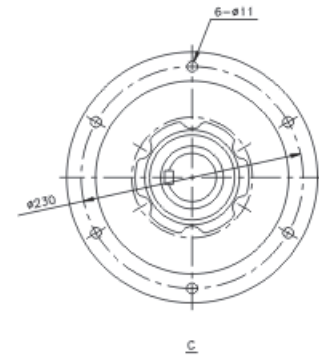
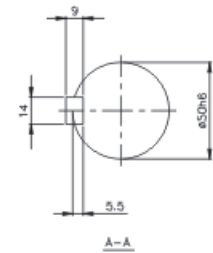
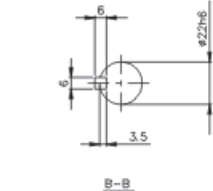
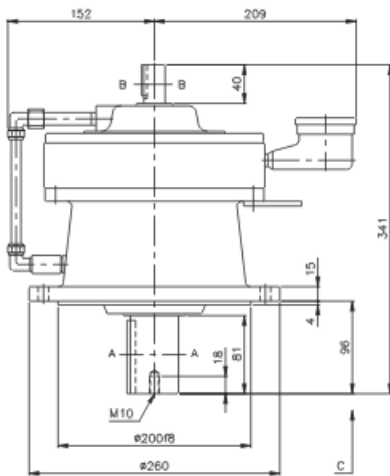



**TDV-615**  
 Weight 43 kg,  
 95 lbs

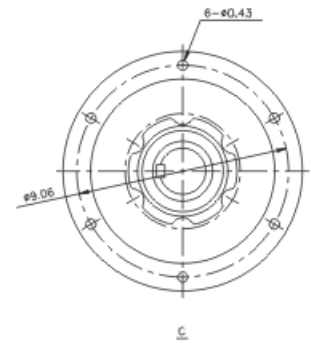
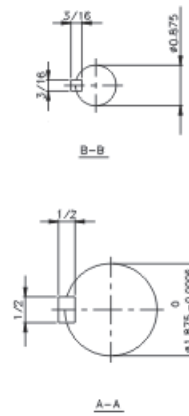
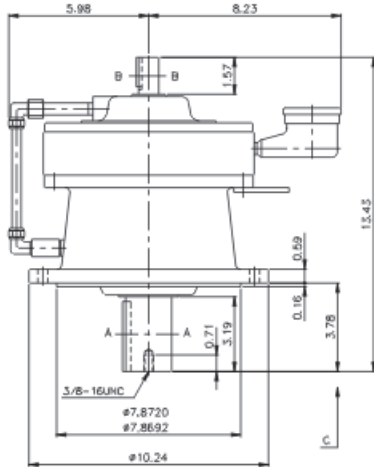
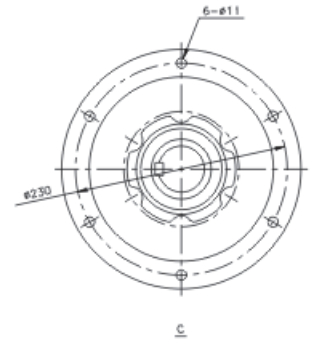
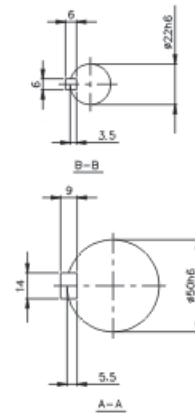
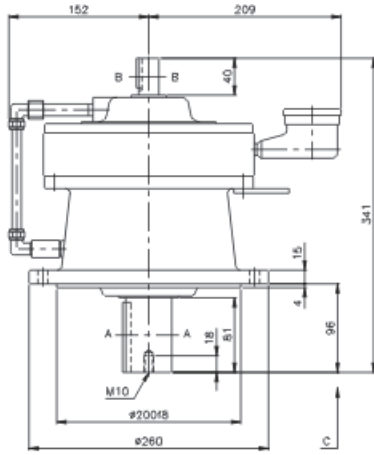

**TDV-616**  
 Weight 80 kg,  
 176 lbs

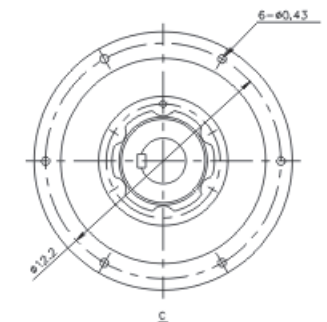
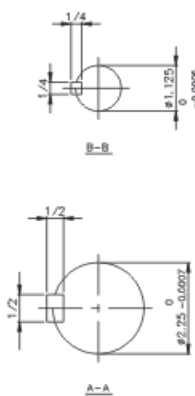
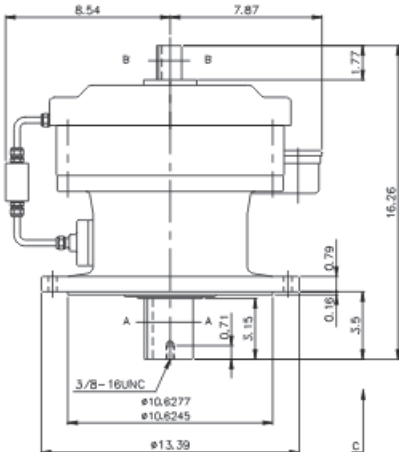
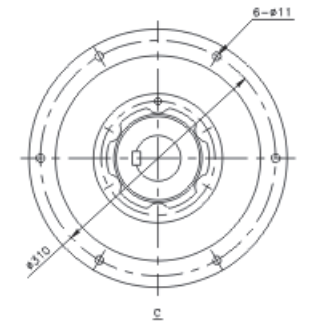
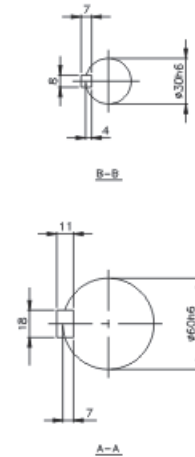
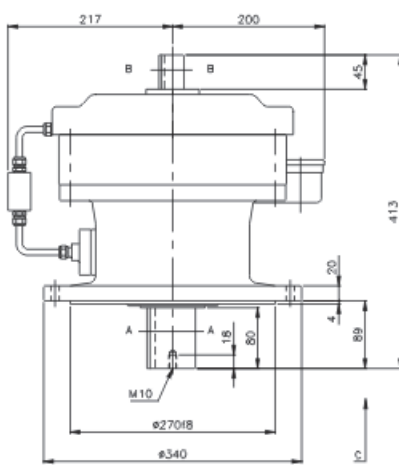

**TDV-617**  
 Weight 125 kg,  
 275 lbs

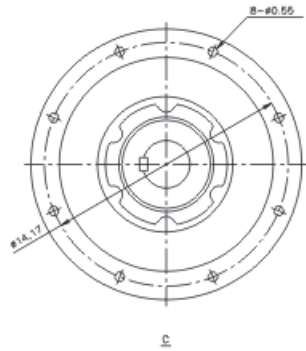
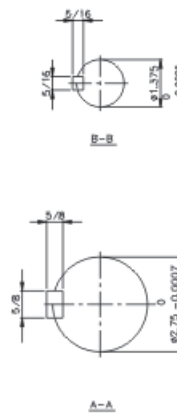
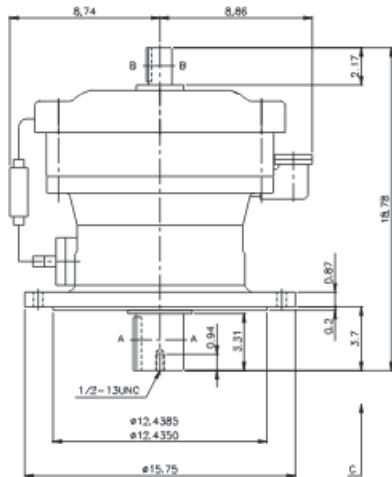
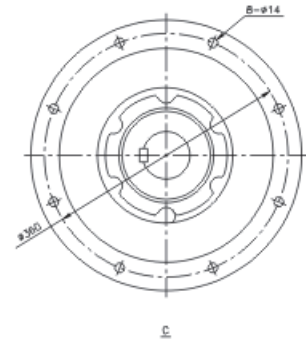
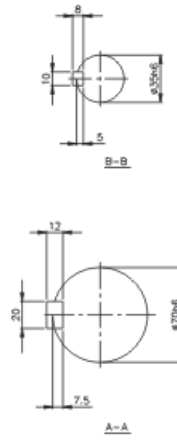
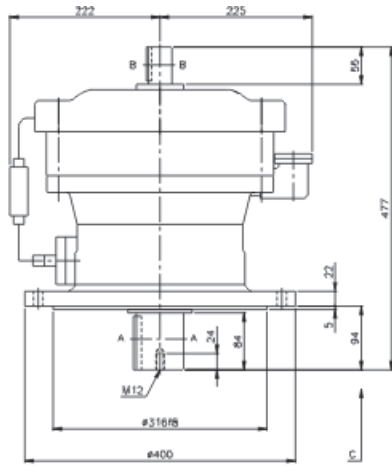

**TDV-618**  
 Weight 150 kg,  
 330 lbs

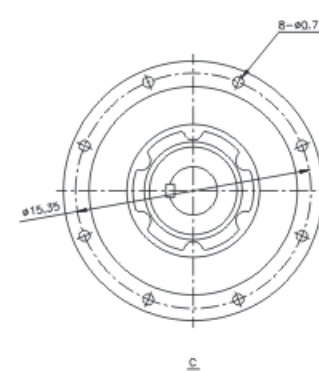
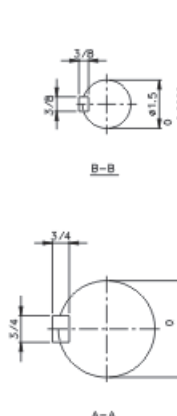
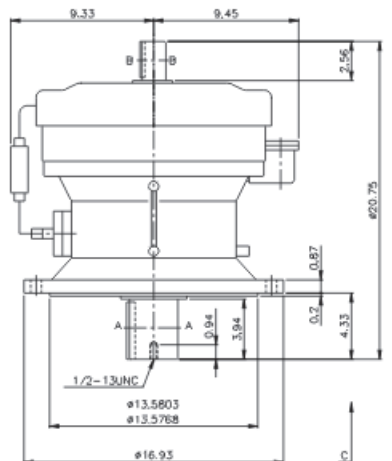
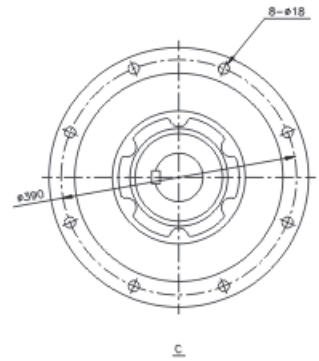
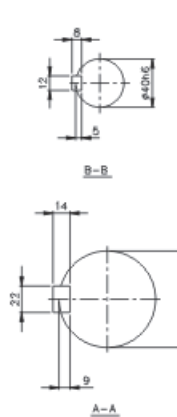
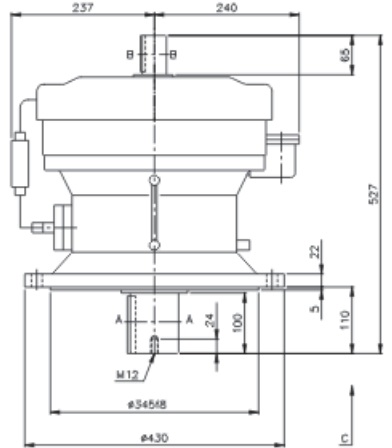

**TDV-619**

Weight 226 kg,  
497 lbs

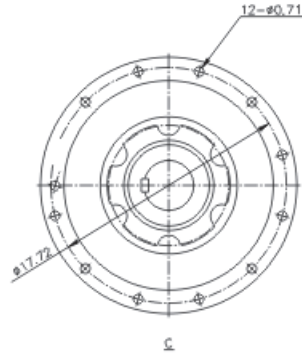
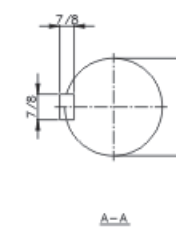
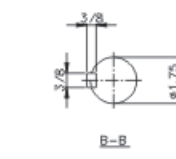
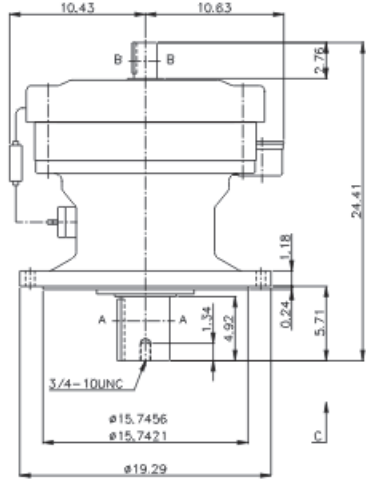
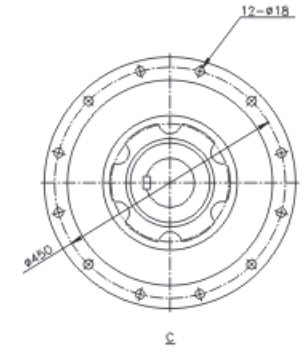
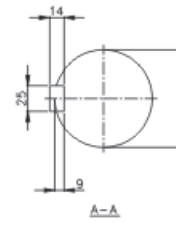
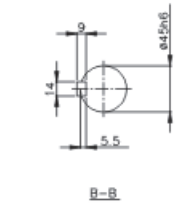
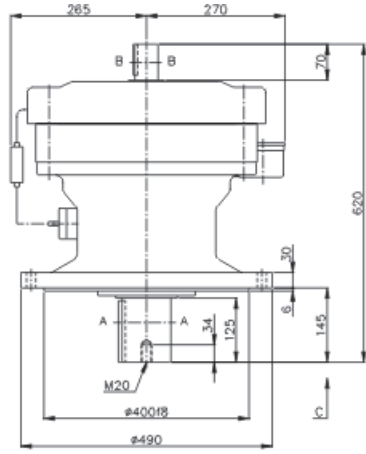

**TDV-620**

Weight 245 kg,  
539 lbs

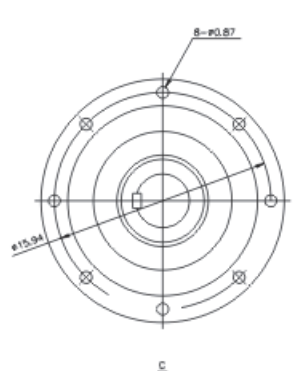
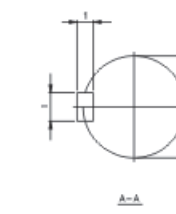
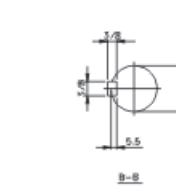
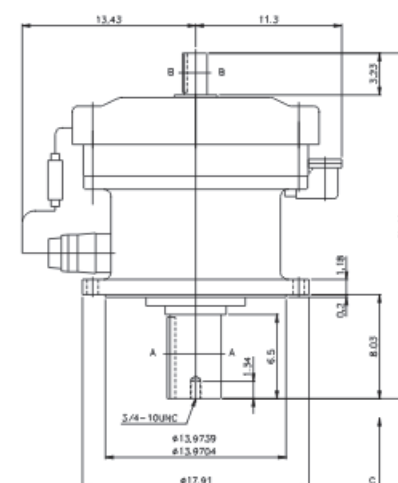
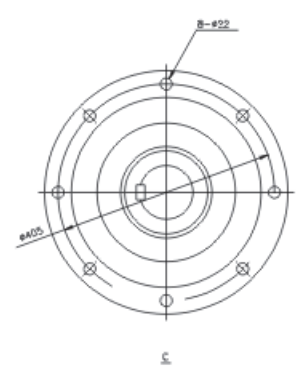
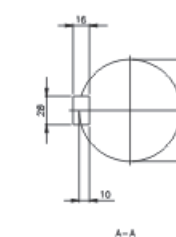
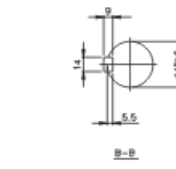
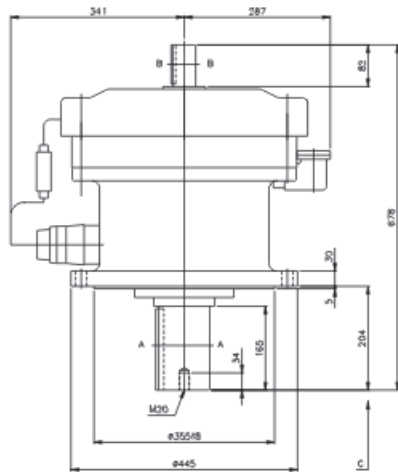



**TDV-621**  
 Weight 315 kg,  
 693 lbs

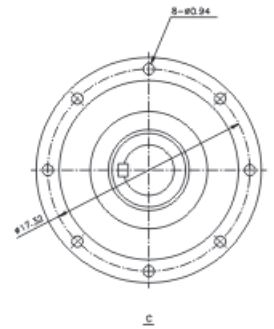
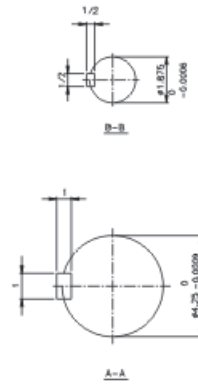
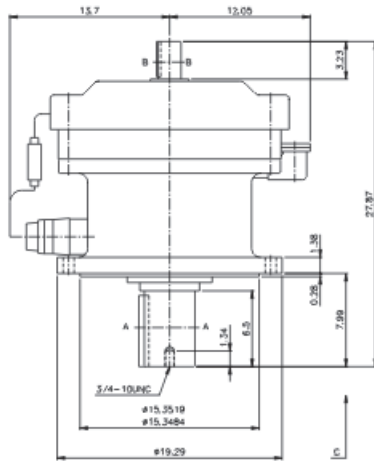
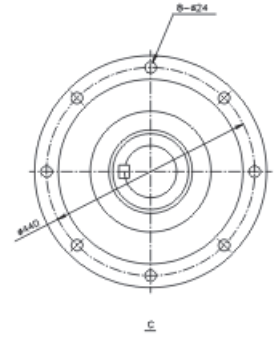
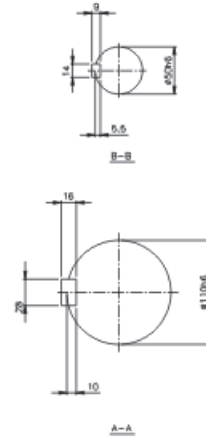
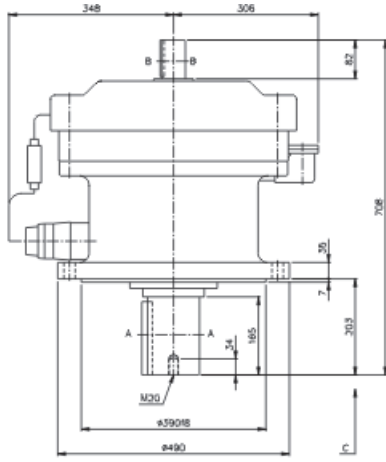

**TDV-622**  
 Weight 398 kg,  
 876 lbs

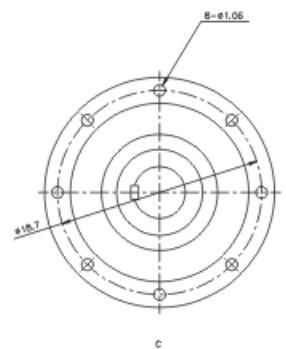
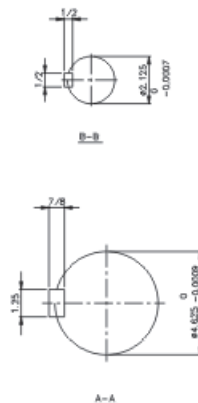
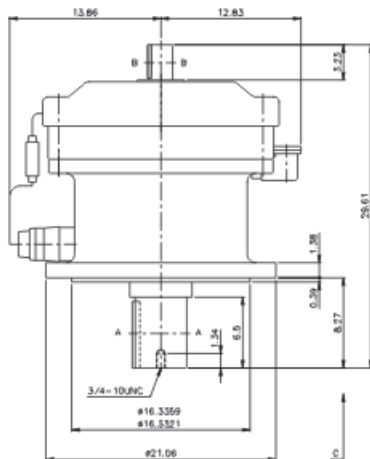
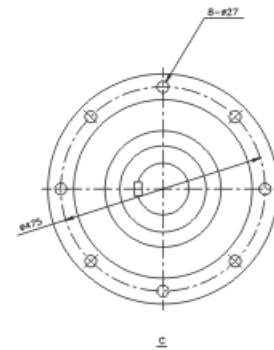
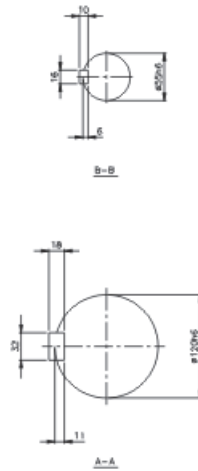
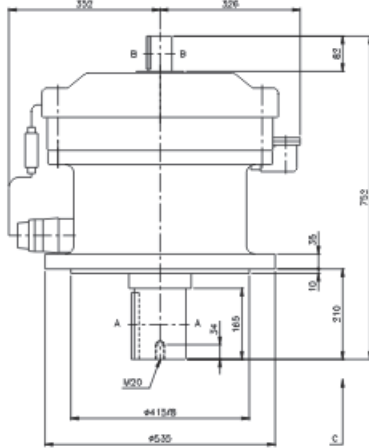

**TDV-623**

Weight 475 kg,  
1045 lbs

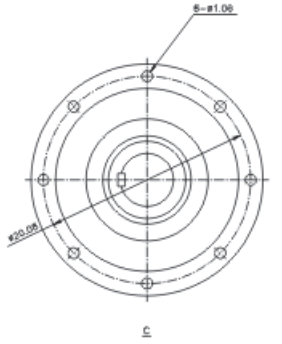
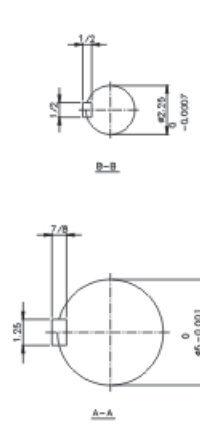
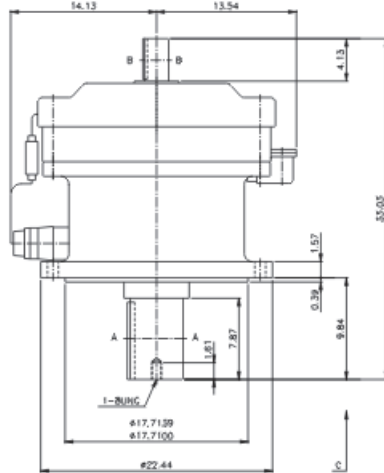
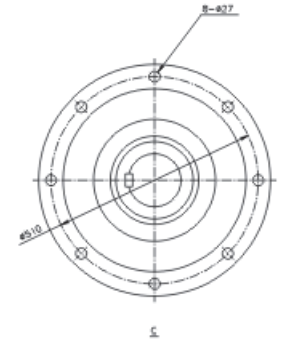
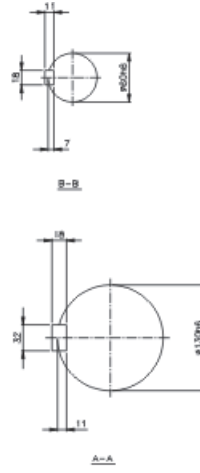
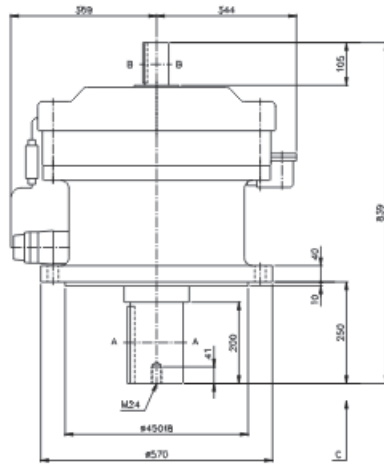

**TDV-624**

Weight 570 kg,  
1254 lbs

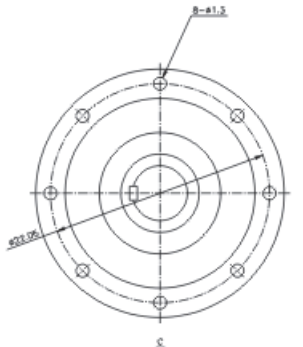
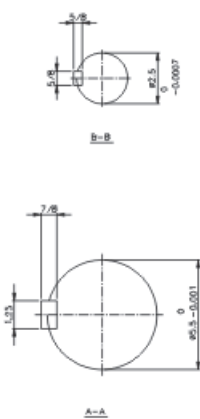
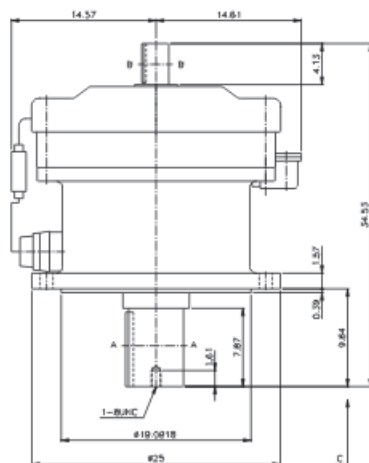
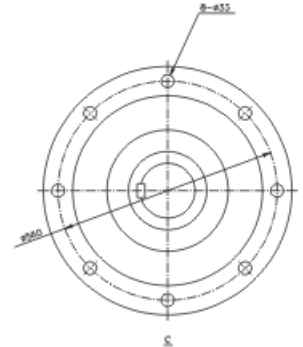
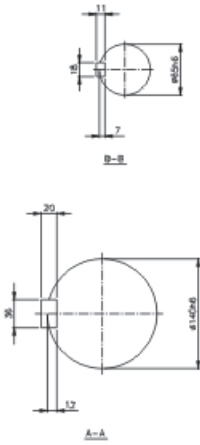
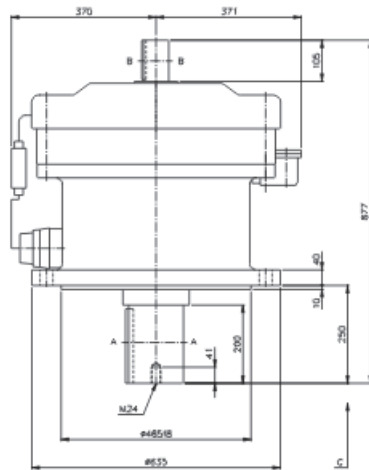





**TDV-627** Weight 2611kg, 5744 lbs

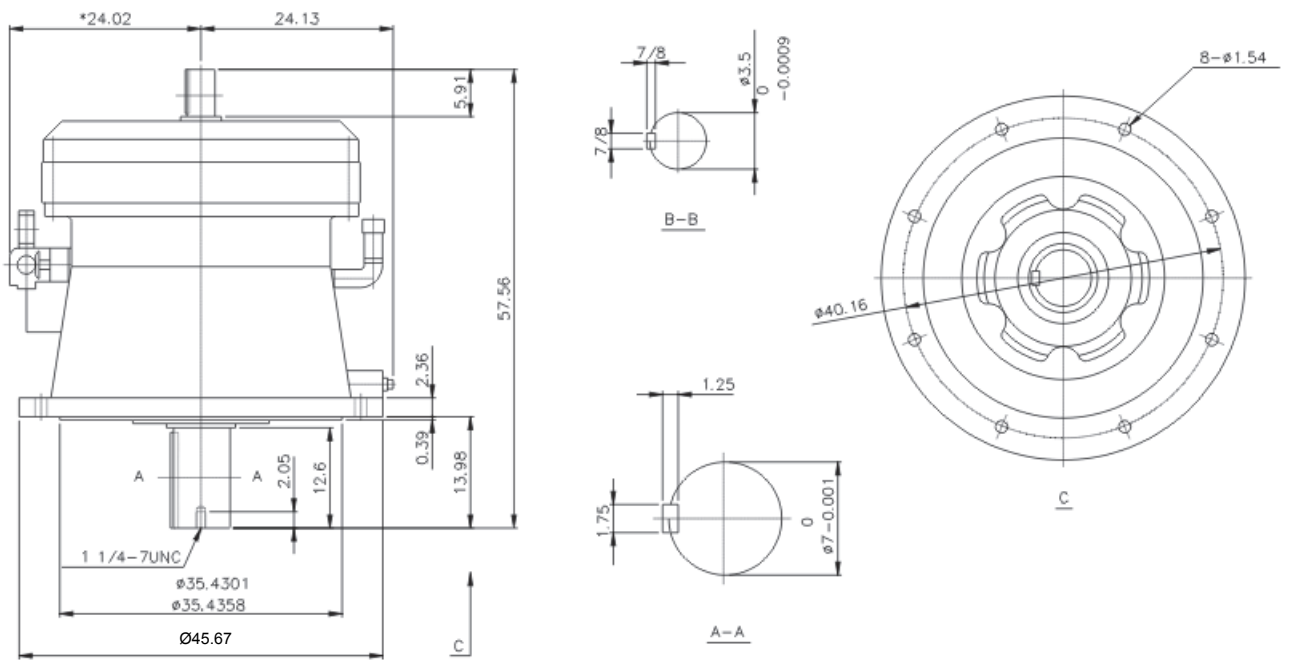
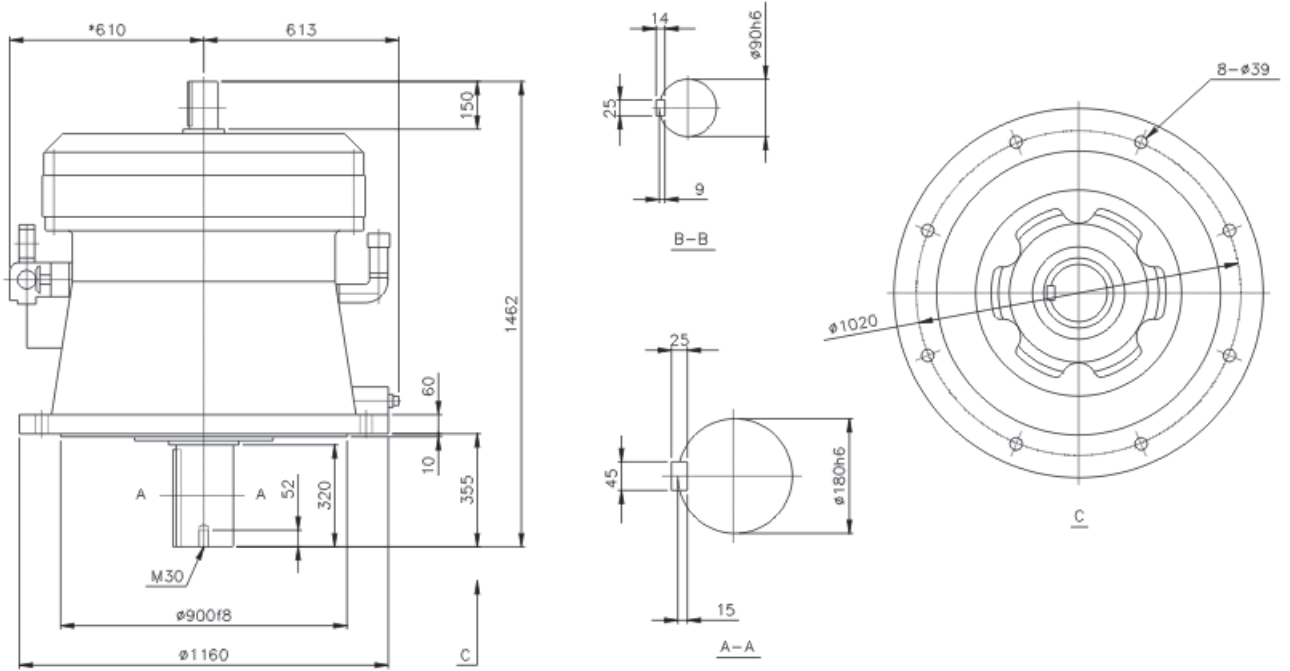

# DIMENSION DRAWINGS F-TYPE Flange TRANSCYKO Speed Reducers

## THF-607~THF-612

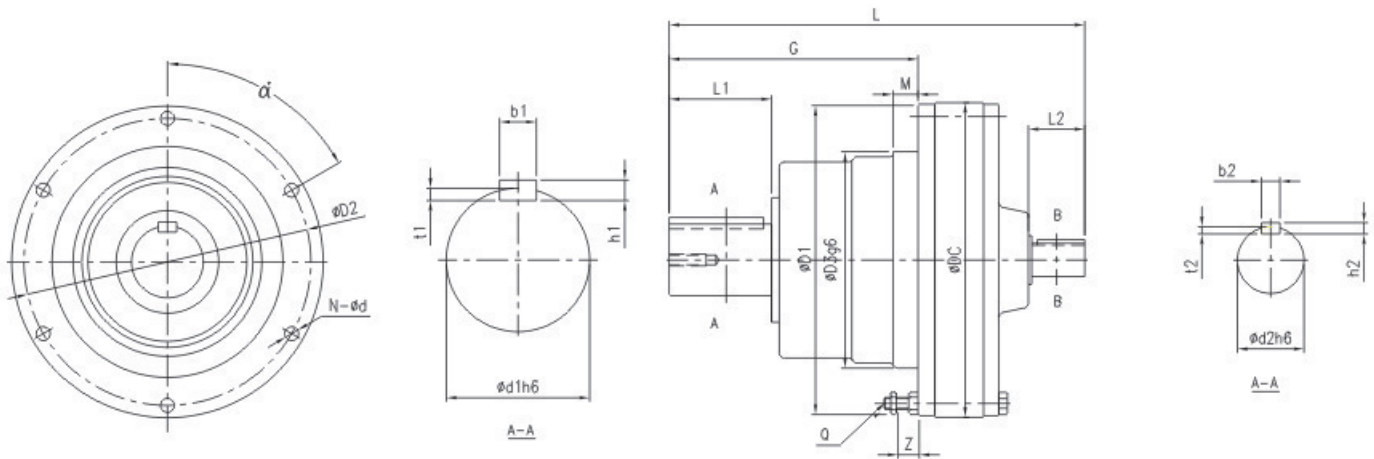

Installation Dimensions THF-607~THF-612																										
THF	Metric ( mm,kg )													Inches ( in,lbs )												
	L	G	D1	D2	D3	DC	Q	Z	M	N	d	$\alpha^\circ$	W(kg)	L	G	D1	D2	D3	DC	Q	Z	M	N	d	$\alpha^\circ$	W(kg)
607	145	69	110	98	75	110	M6	21	4	6	6.6	60	3	5.71	2.72	4.33	3.86	2.95	4.33	1/4	0.83	0.16	6	0.26	60	6.6
608	151	74	110	98	80	110	M6	21	4	6	6.6	60	3	5.94	2.91	4.33	3.86	3.15	4.33	1/4	0.83	0.16	6	0.26	60	6.6
609	202	114	150	134	105	150	M8	29	6	8	9	22.5	8.5	7.95	4.49	5.91	5.28	4.13	5.91	1/3	1.14	0.24	8	0.35	22.5	18.7
610	208	114	150	134	105	150	M8	28	6	8	9	22.5	9.5	8.19	4.49	5.91	5.28	4.13	5.91	1/3	1.10	0.24	8	0.35	22.5	20.9
611	218	118	162	146	115	162	M8	26	6	8	9	22.5	11	8.58	4.65	6.38	5.75	4.53	6.38	1/3	1.02	0.24	8	0.35	22.5	24.2
612	259	139	200	180	140	204	M10	33	14	6	11	60	20	10.20	5.47	7.87	7.09	5.51	8.03	3/8	1.30	0.55	6	0.43	60	44

Frame Size	Output Shaft ( mm )							Input Shaft ( mm )					Output Shaft ( in )							Input Shaft ( in )				
	d1	L1	b1	h1	t1	S1	m1	d2	L2	b2	h2	t2	d1	L1	b1	h1	t1	S1	m1	d2	L2	b2	h2	t2
THF-607-Ratio	14	25	5	5	3	-	-	12	25	4	4	2.5	0.55	0.98	0.20	0.20	0.12	-	-	0.47	0.98	0.16	0.16	0.10
THF-608-Ratio	18	30	6	6	3.5	-	-	12	25	4	4	2.5	0.71	1.18	0.24	0.24	0.14	-	-	0.47	0.98	0.16	0.16	0.10
THF-609-Ratio	28	35	8	7	4	-	-	15	25	5	5	3	1.10	1.38	0.31	0.28	0.16	-	-	0.59	0.98	0.20	0.20	0.12
THF-610-Ratio	28	35	8	7	4	-	-	15	25	5	5	3	1.10	1.38	0.31	0.28	0.16	-	-	0.59	0.98	0.20	0.20	0.12
THF-611-Ratio	32	45	10	8	5	-	-	15	25	5	5	3	1.26	1.77	0.39	0.31	0.20	-	-	0.59	0.98	0.20	0.20	0.12
THF-612-Ratio	38	55	10	8	5	-	-	18	35	6	6	3.5	1.50	2.17	0.39	0.31	0.20	-	-	0.71	1.38	0.24	0.24	0.14

# THF-613~THF-626

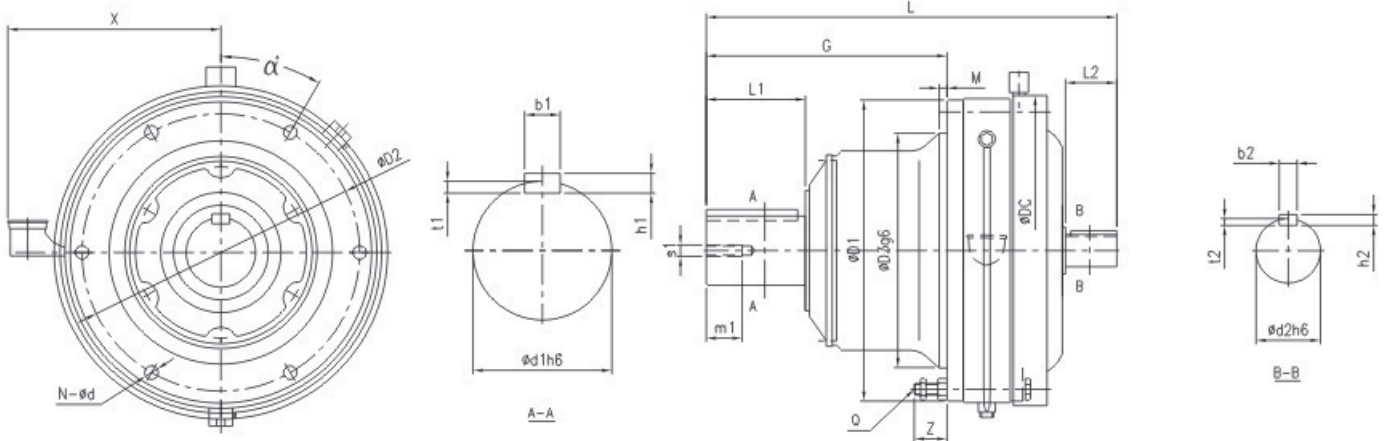

Installation Dimensions THF-613~THF-626

THF	Metric ( mm,kg )															Inches ( in,lbs )										$\alpha^\circ$		
	L	G	D1	D2	D3	DC	Q	Z	M	N	d	$\alpha^\circ$	X	W(kg)	L	G	D1	D2	D3	DC	Q	Z	M	N	d		$\alpha^\circ$	X
613	321	178	226	205	165	230	M10	31	16	6	11	60	208	36	12.64	7.01	8.90	8.07	6.50	9.06	3/8	1.22	0.63	6	0.43	60	8.19	79.2
614	341	198	226	205	165	230	M10	31	16	6	11	60	208	37	13.43	7.80	8.90	8.07	6.50	9.06	3/8	1.22	0.63	6	0.43	60	8.19	81.4
615	341	198	226	205	165	230	M10	31	16	6	11	60	208	37	13.43	7.80	8.90	8.07	6.50	9.06	3/8	1.22	0.63	6	0.43	60	8.19	81.4
616	413	222	296	270	200	318	M12	35	10	6	14	30	228	66	16.26	8.74	11.65	10.63	7.87	12.52	1/2	1.38	0.39	6	0.55	30	8.98	145.2
617	477	262	330	300	250	362	M12	41	12	8	14	22.5	234	96	18.78	10.31	12.99	11.81	9.84	14.25	1/2	1.61	0.47	8	0.55	22.5	9.57	211.2
618	527	299	360	330	280	390	M12	38	12	8	14	22.5	258	131	20.75	11.77	14.17	12.99	11.02	15.35	1/2	1.50	0.47	8	0.55	22.5	10.16	288.2
619	620	365	420	380	320	451	M12	41	10	12	14	15	285	195	24.41	14.37	16.54	14.96	12.60	17.76	1/2	1.61	0.39	12	0.55	15	11.22	429
620	678	410	443	405	360	471	M16	56	20	12	18	15	-	213	26.69	16.14	17.44	15.94	14.17	18.54	5/8	2.20	0.79	12	0.71	15	-	468.6
621	708	423	480	440	390	507	M18	56	20	12	20.5	15	-	292	27.87	16.65	18.90	17.32	15.35	19.96	5/7	2.20	0.79	12	0.81	15	-	642.4
622	752	454	521	475	420	549	M20	64	20	12	22	15	-	347	29.61	17.87	20.51	18.70	16.54	21.61	3/4	2.52	0.79	12	0.87	15	-	763.4
623	839	505	557	510	455	591	M20	65	20	12	22	15	-	428	33.03	19.88	21.93	20.08	17.91	23.27	3/4	2.56	0.79	12	0.87	15	-	941.6
624	877	529	615	560	500	637	M24	65	25	12	27	15	-	538	34.53	20.83	24.21	22.05	19.69	25.08	1	2.56	0.98	12	1.06	15	-	1183.6
625	1040	616	666	610	540	703	M24	91	30	12	27	15	-	794	40.94	24.25	26.22	24.02	21.26	27.68	1	3.58	1.18	12	1.06	15	-	1746.8
626	1150	712	730	660	570	772	M30	85	40	12	34	15	-	1020	45.28	28.03	28.74	25.98	22.44	30.39	1 <sup>1/4</sup>	3.35	1.57	12	1.34	15	-	2244

Frame Size	Output Shaft ( mm )							Input Shaft ( mm )					Output Shaft ( in )						Input Shaft ( in )					
	d1	L1	b1	h1	t1	S1	m1	d2	L2	b2	h2	t2	d1	L1	b1	h1	t1	S1	m1	d2	L2	b2	h2	t2
THF-613-Ratio	50	70	14	9	5.5	M10	18	22	40	6	6	3.5	1.97	2.76	0.55	0.35	0.22	3/8	0.71	0.87	1.57	0.24	0.24	0.14
THF-614-Ratio	50	90	14	9	5.5	M10	18	22	40	8	6	3.5	1.97	3.54	0.55	0.35	0.22	3/8	0.71	0.87	1.57	0.31	0.24	0.14
THF-615-Ratio	50	90	14	9	5.5	M10	18	22	40	8	6	3.5	1.97	3.54	0.55	0.35	0.22	3/8	0.71	0.87	1.57	0.31	0.24	0.14
THF-616-Ratio	60	90	18	11	7	M10	18	30	45	8	7	4	2.36	3.54	0.71	0.43	0.28	3/8	0.71	1.18	1.77	0.31	0.28	0.16
THF-617-Ratio	70	90	20	12	7.5	M12	24	35	55	10	8	5	2.76	3.54	0.79	0.47	0.30	1/2	0.94	1.38	2.17	0.39	0.31	0.20
THF-618-Ratio	80	110	22	14	9	M12	24	40	65	12	8	5	3.15	4.33	0.87	0.55	0.35	1/2	0.94	1.57	2.56	0.47	0.31	0.20
THF-619-Ratio	95	135	25	14	9	M20	34	45	70	14	9	5.5	3.74	5.31	0.98	0.55	0.35	3/4	1.34	1.77	2.76	0.55	0.35	0.22
THF-620-Ratio	100	165	28	16	10	M20	34	45	82	14	9	5.5	3.94	6.50	1.10	0.63	0.39	3/4	1.34	1.77	3.23	0.55	0.35	0.22
THF-621-Ratio	110	165	28	16	10	M20	34	50	82	14	9	5.5	4.33	6.50	1.10	0.63	0.39	3/4	1.34	1.97	3.23	0.55	0.35	0.22
THF-622-Ratio	120	165	32	18	11	M20	34	55	82	16	10	6	4.72	6.50	1.26	0.71	0.43	3/4	1.34	2.17	3.23	0.63	0.39	0.24
THF-623-Ratio	130	200	32	18	11	M24	41	60	105	18	11	7	5.12	7.87	1.26	0.71	0.43	1	1.61	2.36	4.13	0.71	0.43	0.28
THF-624-Ratio	140	200	36	20	12	M24	41	65	105	18	11	7	5.51	7.87	1.42	0.79	0.47	1	1.61	2.56	4.13	0.71	0.43	0.28
THF-625-Ratio	160	240	40	22	13	M30	49	80	130	22	14	9	6.30	9.45	1.57	0.87	0.51	1 <sup>1/4</sup>	1.93	3.15	5.12	0.87	0.55	0.35
THF-626-Ratio	170	300	40	22	13	M30	49	80	130	22	14	9	6.69	11.81	1.57	0.87	0.51	1 <sup>1/4</sup>	1.93	3.15	5.12	0.87	0.55	0.35



# THF-607/07~THF-611/09

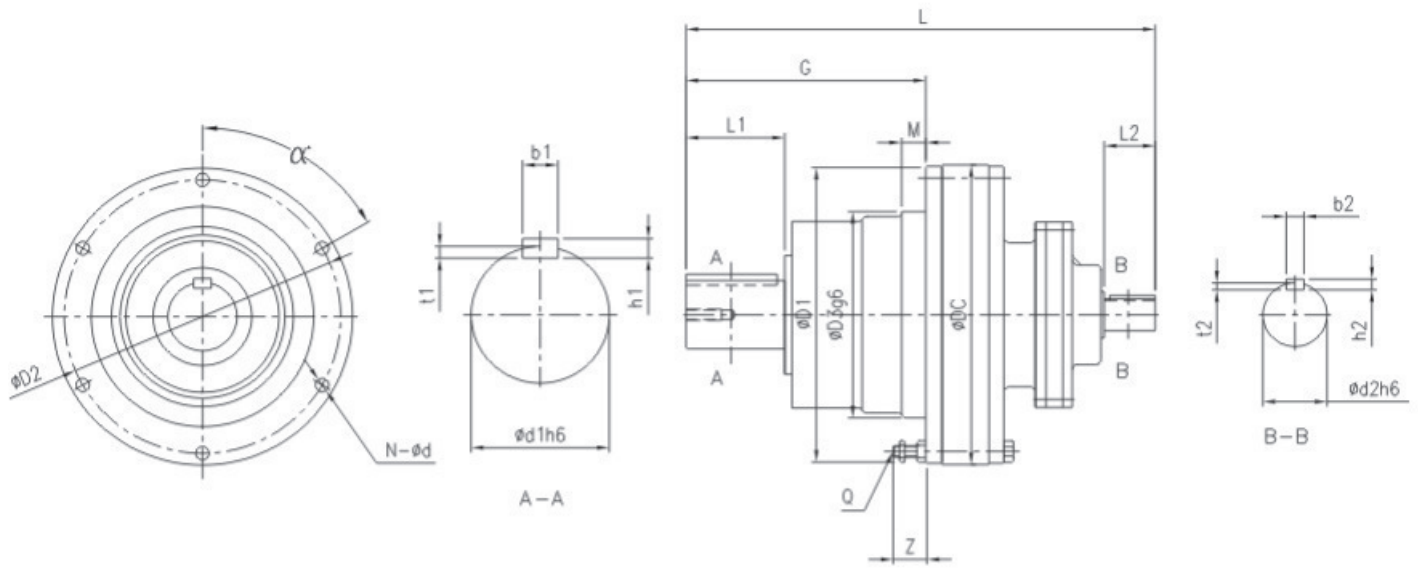

Installation Dimensions THF-607/07~THF-611/09

THF	Metric ( mm,kg )													Inches ( in,lbs )												
	L	G	D1	D2	D3	DC	Q	Z	M	N	d	$\alpha^*$	W(kg)	L	G	D1	D2	D3	DC	Q	Z	M	N	d	$\alpha^*$	W(kg)
607/07	178	69	110	98	75	110	M6	22	4	6	6.6	60	4.5	7.01	2.72	4.33	3.86	2.95	4.33	1/4	0.87	0.16	6	0.26	60	9.9
608/07	184	74	110	98	80	110	M6	21	4	6	6.6	60	4.5	7.24	2.91	4.33	3.86	3.15	4.33	1/4	0.83	0.16	6	0.26	60	9.9
609/08	243	114	150	134	105	150	M8	29	6	8	9	22.5	10	9.57	4.49	5.91	5.28	4.13	5.91	1/3	1.14	0.24	8	0.35	22.5	22
610/08	257	114	150	134	105	150	M8	28	6	8	9	22.5	12	10.12	4.49	5.91	5.28	4.13	5.91	1/3	1.10	0.24	8	0.35	22.5	26.4
611/08	293	139	200	180	140	204	M10	33	14	6	11	60	22	11.54	5.47	7.87	7.09	5.51	8.03	3/8	1.30	0.55	6	0.43	60	48.4
611/09	312	139	200	180	140	204	M10	33	14	6	11	60	25	12.28	5.47	7.87	7.09	5.51	8.03	3/8	1.30	0.55	6	0.43	60	55

Frame Size	Output Shaft ( mm )							Input Shaft ( mm )					Output Shaft ( in )						Input Shaft ( in )					
	d1	L1	b1	h1	t1	S1	m1	d2	L2	b2	h2	t2	d1	L1	b1	h1	t1	S1	m1	d2	L2	b2	h2	t2
THF-607/07-Ratio	14	25	5	5	3	-	-	12	25	4	4	2.5	0.55	0.98	0.20	0.20	0.12	-	-	0.47	0.98	0.16	0.16	0.10
THF-608/07-Ratio	18	30	6	6	3.5	-	-	12	25	4	4	2.5	0.71	1.18	0.24	0.24	0.14	-	-	0.47	0.98	0.16	0.16	0.10
THF-609/08-Ratio	28	35	8	7	4	-	-	12	25	4	4	2.5	1.10	1.38	0.31	0.28	0.16	-	-	0.47	0.98	0.16	0.16	0.10
THF-610/08-Ratio	28	35	8	7	4	-	-	12	25	4	4	2.5	1.10	1.38	0.31	0.28	0.16	-	-	0.47	0.98	0.16	0.16	0.10
THF-611/08-Ratio	38	55	10	8	5	-	-	12	25	4	4	2.5	1.50	2.17	0.39	0.31	0.20	-	-	0.47	0.98	0.16	0.16	0.10
THF-611/09-Ratio	38	55	10	8	5	-	-	15	25	5	5	3	1.50	2.17	0.39	0.31	0.20	-	-	0.59	0.98	0.20	0.20	0.12

# THF-613/08~THF-618/10

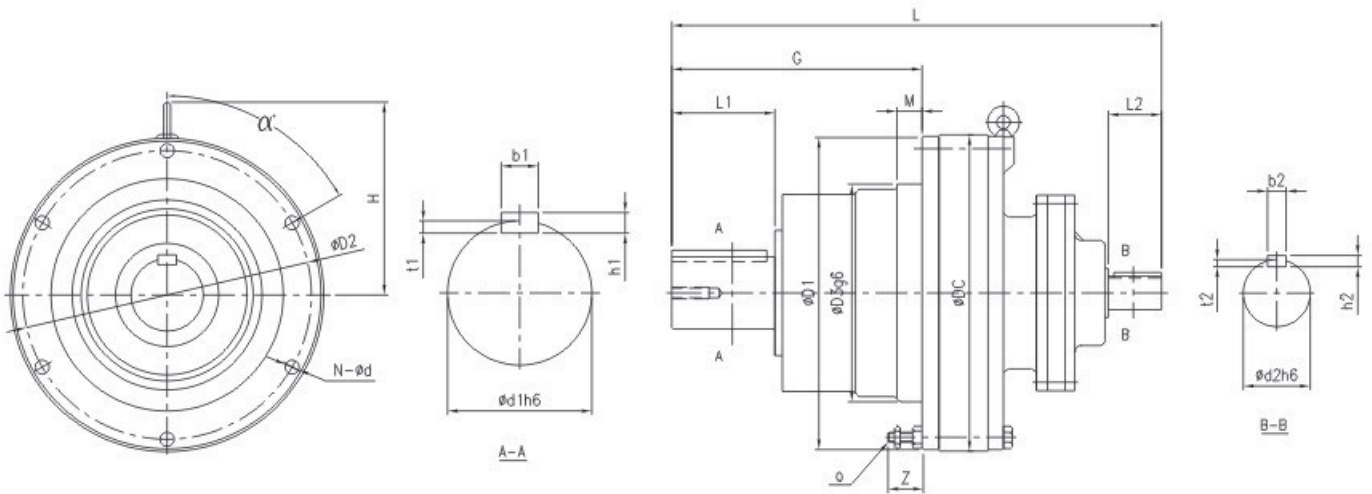

Installation Dimensions THF-613/08~THF-618/10

THF	Metric ( mm, kgs )														Inches ( in, lbs )													
	L	G	D1	D2	D3	DC	H	Q	Z	M	N	d	α°	W(kg)	L	G	D1	D2	D3	DC	H	Q	Z	M	N	d	α°	W(kg)
613/08	347	178	226	205	165	230	150	M10	31	16	6	11	60	36	13.66	7.01	8.90	8.07	6.50	9.06	5.91	3/8	1.22	0.63	6	0.43	60	79.2
613/09	363	178	226	205	165	230	150	M10	31	16	6	11	60	39	14.29	7.01	8.90	8.07	6.50	9.06	5.91	3/8	1.22	0.63	6	0.43	60	85.8
613/10	369	178	226	205	165	230	150	M10	31	16	6	11	60	40	14.53	7.01	8.90	8.07	6.50	9.06	5.91	3/8	1.22	0.63	6	0.43	60	88
614/08	367	198	226	205	165	230	150	M10	31	16	6	11	60	36	14.45	7.80	8.90	8.07	6.50	9.06	5.91	3/8	1.22	0.63	6	0.43	60	78.2
614/09	383	198	226	205	165	230	150	M10	31	16	6	11	60	39	15.08	7.80	8.90	8.07	6.50	9.06	5.91	3/8	1.22	0.63	6	0.43	60	85.8
614/10	389	198	226	205	165	230	150	M10	31	16	6	11	60	40	15.31	7.80	8.90	8.07	6.50	9.06	5.91	3/8	1.22	0.63	6	0.43	60	88
616/09	433	222	296	270	200	300	189	M12	35	10	6	14	30	68	17.05	8.74	11.65	10.63	7.87	11.81	7.44	1/2	1.38	0.39	6	0.55	30	149.6
616/10	439	222	296	270	200	300	189	M12	35	10	6	14	30	70	17.28	8.74	11.65	10.63	7.87	11.81	7.44	1/2	1.38	0.39	6	0.55	30	154
617/09	478	262	330	300	250	340	216	M12	41	12	8	14	22.5	93	18.82	10.31	12.99	11.81	9.84	13.39	8.50	1/2	1.61	0.47	8	0.55	22.5	204.6
617/10	484	262	330	300	250	340	216	M12	41	12	8	14	22.5	95	19.06	10.31	12.99	11.81	9.84	13.39	8.50	1/2	1.61	0.47	8	0.55	22.5	209
618/10	526	299	360	300	280	370	231	M12	38	12	8	14	22.5	129	20.71	11.77	14.17	11.81	11.02	14.57	9.09	1/2	1.50	0.47	8	0.55	22.5	283.8

Frame Size	Output Shaft ( mm )							Input Shaft ( mm )					Output Shaft ( in )					Input Shaft ( mm )						
	d1	L1	b1	h1	t1	S1	m1	d2	L2	b2	h2	t2	d1	L1	b1	h1	t1	S1	m1	d2	L2	b2	h2	t2
THF-613/08-Ratio	50	70	14	9	5.5	M10	18	12	25	4	4	2.5	1.97	2.76	0.55	0.35	0.22	3/8	0.71	0.47	0.98	0.16	0.16	0.10
THF-613/09-Ratio	50	70	14	9	5.5	M10	18	15	25	5	5	3	1.97	2.76	0.55	0.35	0.22	3/8	0.71	0.59	0.98	0.20	0.20	0.12
THF-613/10-Ratio	50	70	14	9	5.5	M10	18	15	25	5	5	3	1.97	2.76	0.55	0.35	0.22	3/8	0.71	0.59	0.98	0.20	0.20	0.12
THF-614/08-Ratio	50	90	14	9	5.5	M10	18	12	25	4	4	2.5	1.97	3.54	0.55	0.35	0.22	3/8	0.71	0.47	0.98	0.16	0.16	0.10
THF-614/09-Ratio	50	90	14	9	5.5	M10	18	15	25	5	5	3	1.97	3.54	0.55	0.35	0.22	3/8	0.71	0.59	0.98	0.20	0.20	0.12
THF-614/10-Ratio	60	90	14	9	5.5	M10	18	15	25	5	5	3	2.36	3.54	0.55	0.35	0.22	3/8	0.71	0.59	0.98	0.20	0.20	0.12
THF-616/09-Ratio	60	90	18	11	7	M10	18	15	25	5	5	3	2.36	3.54	0.71	0.43	0.28	3/8	0.71	0.59	0.98	0.20	0.20	0.12
THF-616/10-Ratio	60	90	18	11	7	M10	18	15	25	5	5	3	2.36	3.54	0.71	0.43	0.28	3/8	0.71	0.59	0.98	0.20	0.20	0.12
THF-617/09-Ratio	70	90	20	12	7.5	M12	24	15	25	5	5	3	2.76	3.54	0.79	0.47	0.30	1/2	0.94	0.59	0.98	0.20	0.20	0.12
THF-617/10-Ratio	70	90	20	12	7.5	M12	24	15	25	5	5	3	2.76	3.54	0.79	0.47	0.30	1/2	0.94	0.59	0.98	0.20	0.20	0.12
THF-618/10-Ratio	80	110	22	14	9	M12	24	15	25	5	5	3	3.15	4.33	0.87	0.55	0.35	1/2	0.94	0.59	0.98	0.20	0.20	0.12



# THF-616/11~THF-626/19

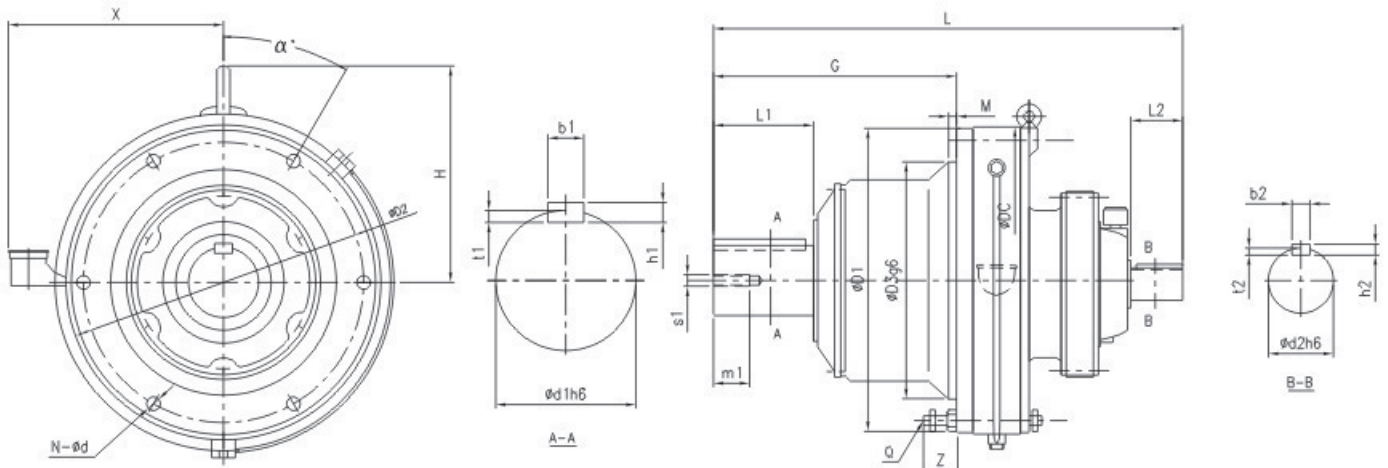

Installation Dimensions THF-616/11~THF-626/19																														
THF	Metric ( mm,kgs )																	Inches ( in,lbs )												
	L	G	D1	D2	D3	DC	H	Q	Z	M	N	d	α°	x	W(kg)	L	G	D1	D2	D3	DC	H	Q	Z	M	N	d	α°	x	W(kg)
616/11	462	222	296	270	200	300	189	M12	35	10	6	14	30	228	82	18.19	8.74	11.65	10.63	7.87	11.81	7.44	1/2	1.38	0.39	6	0.55	30	8.98	180.4
617/11	509	262	330	300	250	340	216	M12	41	12	8	14	22.5	243	105	20.04	10.31	12.99	11.81	9.84	13.39	8.50	1/2	1.61	0.47	8	0.55	225	9.57	231
618/13	577	299	360	330	280	370	231	M12	38	12	8	14	22.5	258	146	22.72	11.77	14.17	12.99	11.02	14.57	9.09	1/2	1.50	0.47	8	0.55	225	10.16	3212
619/11	629	365	420	380	320	430	281	M12	41	10	12	14	15	285	201	24.76	14.37	16.54	14.93	12.60	16.93	11.06	1/2	1.61	0.39	12	0.55	15	11.22	4422
619/13	653	365	420	380	320	430	281	M12	41	10	12	14	15	285	205	25.71	14.37	16.54	14.96	12.60	16.93	11.06	1/2	1.61	0.39	12	0.55	15	11.22	451
620/11	670	410	443	405	360	448	283	M16	56	20	12	18	15	-	217	26.38	16.14	17.44	15.94	14.17	17.64	11.14	5/8	2.20	0.79	12	0.71	15	-	477.4
620/13	705	410	443	405	360	448	283	M16	56	20	12	18	15	-	227	27.76	16.14	17.44	15.94	14.17	17.64	11.14	5/8	2.20	0.79	12	0.71	15	-	499.4
621/13	731	423	480	440	390	485	312	M18	56	20	12	20.5	15	-	306	28.78	16.65	18.90	17.32	15.35	19.09	12.28	5/7	2.20	0.79	12	0.81	15	-	673.2
621/16	780	423	480	440	390	485	312	M18	56	20	12	20.5	15	-	328	30.71	16.66	18.90	17.32	15.35	19.09	12.28	5/7	2.20	0.79	12	0.81	15	-	721.6
622/13	773	454	521	475	420	526	333	M20	64	20	12	22	15	-	357	30.43	17.87	20.51	18.70	16.54	20.71	13.11	3/4	2.52	0.79	12	0.87	15	-	785.4
622/17	860	454	521	475	420	526	333	M20	64	20	12	22	15	-	404	33.86	17.87	20.51	18.70	16.54	20.71	13.11	3/4	2.52	0.79	12	0.87	15	-	888.8
623/16	883	505	557	510	455	562	351	M20	65	20	12	22	15	-	468	34.76	19.68	21.93	20.08	17.91	22.13	13.82	3/4	2.56	0.79	12	0.87	15	-	1029.6
623/18	938	505	557	510	455	562	351	M20	65	20	12	22	15	-	500	36.93	19.88	21.93	20.08	17.91	22.13	13.82	3/4	2.56	0.79	12	0.87	15	-	1100
624/16	921	529	615	560	500	614	395	M24	65	25	12	27	15	-	574	36.25	20.83	24.21	22.05	19.69	24.17	15.55	1	2.56	0.98	12	1.06	15	-	1262.8
624/18	975	529	615	560	500	614	395	M24	65	25	12	27	15	-	603	38.39	20.83	24.21	22.05	19.69	24.17	15.55	1	2.56	0.98	12	1.06	15	-	1326.8
625/17	1081	616	666	610	540	670	386	M24	91	30	12	27	15	-	847	42.56	24.25	26.22	24.02	21.26	26.38	15.20	1	3.58	1.18	12	1.06	15	-	1863.4
625/19	1133	616	666	610	540	670	386	M24	91	30	12	27	15	-	926	44.61	24.25	26.22	24.02	21.26	26.38	15.20	1	3.58	1.18	12	1.06	15	-	2037.2
626/19	1243	712	730	660	570	736	453	M30	85	40	12	34	15	-	1170	48.94	28.03	28.74	25.98	22.44	28.98	17.83	1	3.35	1.57	12	1.34	15	-	2574

Frame Size	Output Shaft ( mm )							Input Shaft ( mm )					Output Shaft ( in )							Input Shaft ( mm )				
	d1	L1	b1	h1	t1	S1	m1	d2	L2	b2	h2	t2	d1	L1	b1	h1	t1	S1	m1	d2	L2	b2	h2	t2
THF-616/11-Ratio	60	90	18	11	7	M10	18	18	35	6	6	3.5	2.36	3.54	0.71	0.43	0.28	3/8	0.71	1.38	0.24	0.24	0.14	
THF-617/11-Ratio	70	90	20	12	7.5	M12	24	18	35	6	6	3.5	2.76	3.54	0.79	0.47	0.30	1/2	0.94	0.71	1.38	0.24	0.24	0.14
THF-618/13-Ratio	80	110	22	14	9	M12	24	22	40	6	6	3.5	3.15	4.33	0.87	0.55	0.35	1/2	0.94	0.87	1.57	0.24	0.24	0.14
THF-619/11-Ratio	95	135	25	14	9	M20	34	18	35	6	6	3.5	3.74	5.31	0.98	0.55	0.35	3/4	1.34	0.71	1.38	0.24	0.24	0.14
THF-619/13-Ratio	95	135	25	14	9	M20	34	22	40	6	6	3.5	3.74	5.31	0.98	0.55	0.35	3/4	1.34	0.87	1.57	0.24	0.24	0.14
THF-620/11-Ratio	100	165	28	16	10	M20	34	18	35	6	6	3.5	3.94	6.50	1.10	0.63	0.39	3/4	1.34	0.71	1.38	0.24	0.24	0.14
THF-620/13-Ratio	100	165	28	16	10	M20	34	22	40	6	6	3.5	3.94	6.50	1.10	0.63	0.39	3/4	1.34	0.87	1.57	0.24	0.24	0.14
THF-621/13-Ratio	110	165	28	16	10	M20	34	22	40	6	6	3.5	4.33	6.50	1.10	0.63	0.39	3/4	1.34	0.87	1.57	0.24	0.24	0.14
THF-621/16-Ratio	110	165	28	16	10	M20	34	30	45	6	7	4.0	4.33	6.50	1.10	0.63	0.39	3/4	1.34	1.18	1.77	0.31	0.28	0.16
THF-622/13-Ratio	120	165	32	18	11	M20	34	22	40	6	6	3.5	4.72	6.50	1.26	0.71	0.43	3/4	1.34	0.87	1.57	0.24	0.24	0.14
THF-622/17-Ratio	120	165	32	18	11	M20	34	35	55	10	8	5.0	4.72	6.50	1.26	0.71	0.43	1	1.34	1.38	2.17	0.39	0.31	0.20
THF-623/16-Ratio	130	200	32	18	11	M24	41	30	45	8	7	4.0	5.12	7.87	1.26	0.71	0.43	1	1.61	1.18	1.77	0.31	0.28	0.16
THF-623/18-Ratio	130	200	32	18	11	M24	41	40	65	12	8	5.0	5.12	7.87	1.26	0.71	0.43	1	1.61	1.57	2.56	0.47	0.31	0.20
THF-624/16-Ratio	140	200	36	20	12	M24	41	30	45	8	7	4.0	5.51	7.87	1.42	0.79	0.47	1	1.61	1.18	1.77	0.31	0.28	0.16
THF-624/18-Ratio	140	200	36	20	12	M24	41	40	65	12	8	5.0	5.51	7.87	1.42	0.79	0.47	1	1.61	1.57	2.56	0.47	0.31	0.20
THF-625/17-Ratio	160	240	40	22	13	M30	49	35	55	10	8	5.0	6.30	9.45	1.57	0.87	0.51	1"	1.93	1.38	2.17	0.39	0.31	0.20
THF-625/19-Ratio	160	240	40	22	13	M30	49	45	70	14	9	5.5	6.30	9.45	1.57	0.87	0.51	1"	1.93	1.77	2.76	0.55	0.35	0.22
THF-626/19-Ratio	170	300	40	22	13	M30	49	45	70	14	9	5.5	6.69	11.81	1.57	0.87	0.51	1"	1.93	1.77	2.76	0.55	0.35	0.22





# TV-608

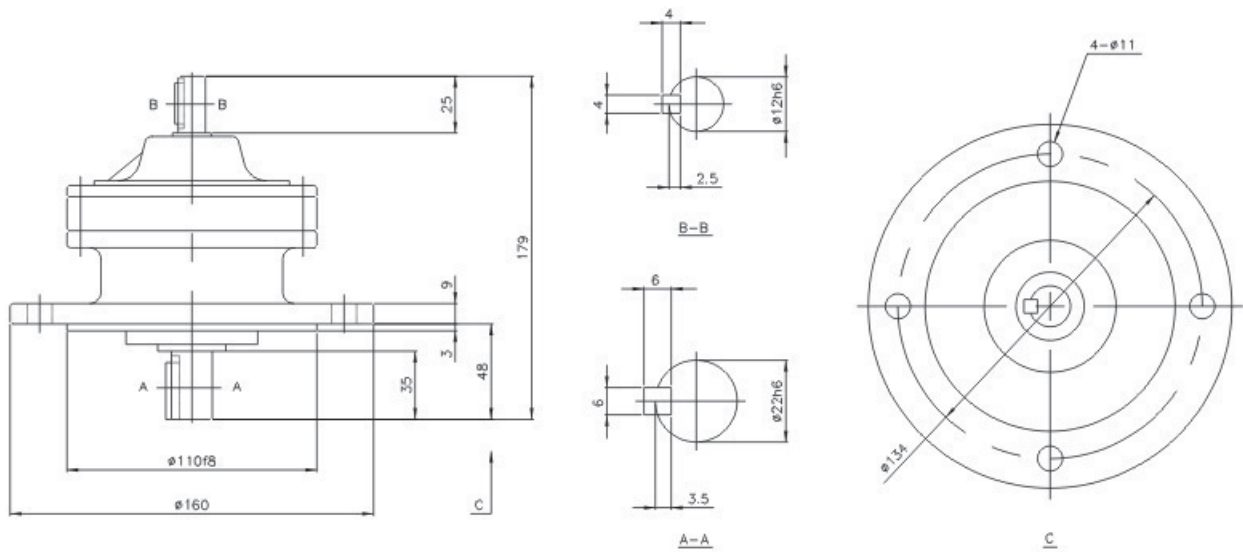

# TH-608

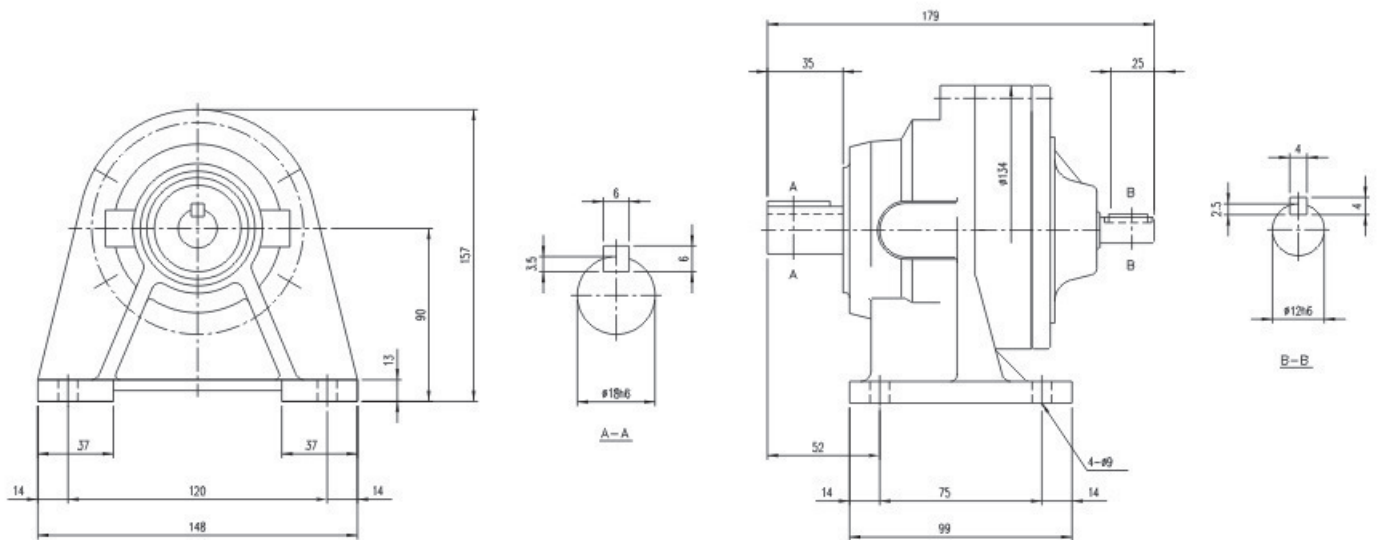

## Selection Tables For 608 Gear motors

608 Cycloid Gear			
Selection Tables For 4 Pole Motor			
Ratio	Frequency	Motor Input Speed	Reducer Output Speed
6	50Hz	1500rpm	250rpm
	60Hz	1800rpm	300rpm

MOTOR			50Hz			60Hz			TRANSCYKO MODEL	Dimension Page	
kW	HP	Symbol	Output Torque kgf.m/in.lbs	Allowable Output Shaft Overhung Load kgf/lbs	S.F.	Output Torque kgf.m/in.lbs	Allowable Output Shaft Overhung Load kgf/lbs	S.F.		H	V
0.2	1/4	02	0.72/62.50	200/440	2.00	0.60/52.08	160/352	2.00	02-608-6	225	225
0.4	1/2	05	1.44/124.99	200/440	1.76	1.20/104.16	160/352	1.10	05-608-6	225	225

## Selection Tables For 608 Gear motors

Ratio	Frequency	Motor Input Speed	Reducer Output Speed
8	50Hz	1500rpm	188rpm
	60Hz	1800rpm	225rpm

MOTOR			50Hz			60Hz			TRANSCYKO MODEL	Dimension Page	
kW	HP	Symbol	Output Torque kgf.m/in.lbs	Allowable Output Shaft Overhung Load kgf/lbs	S.F.	Output Torque kgf.m/in.lbs	Allowable Output Shaft Overhung Load kgf/lbs	S.F.		H	V
0.2	1/4	02	0.96/83.30	200/440	3.60	0.80/69.44	190/418	2.60	02-608-8	225	225
0.4	1/2	05	1.56/135.41	200/440	3.00	1.30/112.84	190/418	2.25	05-608-8	225	225

Ratio	Frequency	Motor Input Speed	Reducer Output Speed
11	50Hz	1500rpm	136rpm
	60Hz	1800rpm	164rpm

MOTOR			50Hz			60Hz			TRANSCYKO MODEL	Dimension Page	
kW	HP	Symbol	Output Torque kgf.m/in.lbs	Allowable Output Shaft Overhung Load kgf/lbs	S.F.	Output Torque kgf.m/in.lbs	Allowable Output Shaft Overhung Load kgf/lbs	S.F.		H	V
0.2	1/4	02	1.32/114.57	200/440	2.54	1.10/95.48	210/462	2.02	02-608-11	225	225
0.4	1/2	05	2.64/229.15	170/374	1.00	2.20/190.96	161/354.2	1.00	05-608-11	225	225

Ratio	Frequency	Motor Input Speed	Reducer Output Speed
13	50Hz	1500rpm	115rpm
	60Hz	1800rpm	138rpm

MOTOR			50Hz			60Hz			TRANSCYKO MODEL	Dimension Page	
kW	HP	Symbol	Output Torque kgf.m/in.lbs	Allowable Output Shaft Overhung Load kgf/lbs	S.F.	Output Torque kgf.m/in.lbs	Allowable Output Shaft Overhung Load kgf/lbs	S.F.		H	V
0.2	1/4	02	1.56/135.41	250/550	2.40	1.30/112.84	220/484	1.90	02-608-13	225	225
0.4	1/2	05	3.12/270.82	250/550	1.87	2.60/225.68	220/484	1.78	05-608-13	225	225

Ratio	Frequency	Motor Input Speed	Reducer Output Speed
15	50Hz	1500rpm	100rpm
	60Hz	1800rpm	120rpm

MOTOR			50Hz			60Hz			TRANSCYKO MODEL	Dimension Page	
kW	HP	Symbol	Output Torque kgf.m/in.lbs	Allowable Output Shaft Overhung Load kgf/lbs	S.F.	Output Torque kgf.m/in.lbs	Allowable Output Shaft Overhung Load kgf/lb	S.F.		H	V
0.2	1/4	02	1.80/156.24	250/550	2.40	1.50/130.2	230/506	1.50	02-608-15	225	225
0.4	1/2	05	3.60/312.48	250/550	1.90	3.00/260.4	230/506	1.90	05-608-15	225	225

Ratio	Frequency	Motor Input Speed	Reducer Output Speed
17	50Hz	1500rpm	88rpm
	60Hz	1800rpm	106rpm

MOTOR			50Hz			60Hz			TRANSCYKO MODEL	Dimension Page	
kW	HP	Symbol	Output Torque kgf.m/in.lbs	Allowable Output Shaft Overhung Load kgf/lbs	S.F.	Output Torque kgf.m/in.lbs	Allowable Output Shaft Overhung Load kgf/lbs	S.F.		H	V
0.2	1/4	02	2.04/177.07	260/572	1.96	1.72/149.30	240/528	1.88	02-608-17	225	225
0.4	1/2	05	4.08/354.14	260/572	1.90	3.40/295.12	240/528	1.80	05-608-17	225	225

Ratio	Frequency	Motor Input Speed	Reducer Output Speed
21	50Hz	1500rpm	71rpm
	60Hz	1800rpm	89rpm



## Selection Tables For 608 Gear motors

MOTOR			50Hz			60Hz			TRANSCYKO MODEL	Dimension Page	
kW	HP	Symbol	Output Torque kgf.m/in.lbs	Allowable Output Shaft Overhung Load kgf/lbs	S.F.	Output Torque kgf.m/in.lbs	Allowable Output Shaft Overhung Load kgf/lbs	S.F.		H	V
0.2	1/4	02	2.52/218.74	180/396	1.00	2.10/182.28	180/396	1.00	02-608-21	225	225
0.4	1/2	05	5.04/437.47	180/396	1.00	4.20/364.56	180/396	1.00	05-608-21	225	225

Ratio	Frequency	Motor Input Speed	Reducer Output Speed
25	50Hz	1500rpm	60rpm
	60Hz	1800rpm	72rpm

MOTOR			50Hz			60Hz			TRANSCYKO MODEL	Dimension Page	
kW	HP	Symbol	Output Torque kgf.m/in.lbs	Allowable Output Shaft Overhung Load kgf/lbs	S.F.	Output Torque kgf.m/in.lbs	Allowable Output Shaft Overhung Load kgf/lbs	S.F.		H	V
0.2	1/4	02	3.00/260.4	250/550	1.35	2.50/217	230/506	1.25	02-608-25	225	225
0.4	1/2	05	6.00/520.8	250/550	1.10	5.00/434	230/506	1.05	05-608-25	225	225

Ratio	Frequency	Motor Input Speed	Reducer Output Speed
29	50Hz	1500rpm	52rpm
	60Hz	1800rpm	62rpm

MOTOR			50Hz			60Hz			TRANSCYKO MODEL	Dimension Page	
kW	HP	Symbol	Output Torque kgf.m/in.lbs	Allowable Output Shaft Overhung Load kgf/lbs	S.F.	Output Torque kgf.m/in.lbs	Allowable Output Shaft Overhung Load kgf/lbs	S.F.		H	V
0.2	1/4	02	3.48/302.06	340/748	3.35	2.90/251.72	340/748	3.40	02-608-29	225	225
0.4	1/2	05	6.96/604.13	240/528	1.10	5.80/503.44	220/484	1.05	05-608-29	225	225

Ratio	Frequency	Motor Input Speed	Reducer Output Speed
35	50Hz	1500rpm	43rpm
	60Hz	1800rpm	51rpm

MOTOR			50Hz			60Hz			TRANSCYKO MODEL	Dimension Page	
kW	HP	Symbol	Output Torque kgf.m/in.lbs	Allowable Output Shaft Overhung Load kgf/lbs	S.F.	Output Torque kgf.m/in.lbs	Allowable Output Shaft Overhung Load kgf/lbs	S.F.		H	V
0.2	1/4	02	4.20/364.56	220/484	1.53	3.50/303.8	210/462	1.51	02-608-35	225	225
0.4	1/2	05	8.40/729.12	220/484	1.10	7.00/607.6	210/462	1.05	05-608-35	225	225

Ratio	Frequency	Motor Input Speed	Reducer Output Speed
43	50Hz	1500rpm	35rpm
	60Hz	1800rpm	42rpm

MOTOR			50Hz			60Hz			TRANSCYKO MODEL	Dimension Page	
kW	HP	Symbol	Output Torque kgf.m/in.lbs	Allowable Output Shaft Overhung Load kgf/lbs	S.F.	Output Torque kgf.m/in.lbs	Allowable Output Shaft Overhung Load kgf/lbs	S.F.		H	V
0.2	1/4	02	5.16/447.89	220/484	1.10	4.30/373.24	210/462	1.05	02-608-43	225	225
0.4	1/2	05	10.3/894.04	250/550	1.50	8.60/746.48	250/550	1.50	05-608-43	225	225

Ratio	Frequency	Motor Input Speed	Reducer Output Speed
51	50Hz	1500rpm	29rpm
	60Hz	1800rpm	35rpm

MOTOR			50Hz			60Hz			TRANSCYKO MODEL	Dimension Page	
kW	HP	Symbol	Output Torque kgf.m/in.lbs	Allowable Output Shaft Overhung Load kgf/lbs	S.F.	Output Torque kgf.m/in.lbs	Allowable Output Shaft Overhung Load kgf/lbs	S.F.		H	V
0.2	1/4	02	6.12/531.22	340/748	1.80	5.10/442.68	340/748	1.80	02-608-51	225	225

## Selection Tables For 808 Gear motors

Ratio	Frequency	Motor Input Speed	Reducer Output Speed
51	50Hz	1500rpm	29rpm
	60Hz	1800rpm	35rpm

MOTOR			50Hz			60Hz			TRANSCYKO MODEL	Dimension Page	
kW	HP	Symbol	Output Torque kgf.m/in.lbs	Allowable Output Shaft Overhung Load kgf/lbs	S.F.	Output Torque kgf.m/in.lbs	Allowable Output Shaft Overhung Load kgf/lbs	S.F.		H	V
0.2	1/4	02	6.12/531.22	340/748	1.80	5.10/442.68	340/748	1.80	02-808-51	225	225

Ratio	Frequency	Motor Input Speed	Reducer Output Speed
51	50Hz	1500rpm	29rpm
	60Hz	1800rpm	35rpm

MOTOR			50Hz			60Hz			TRANSCYKO MODEL	Dimension Page	
kW	HP	Symbol	Output Torque kgf.m/in.lbs	Allowable Output Shaft Overhung Load kgf/lbs	S.F.	Output Torque kgf.m/in.lbs	Allowable Output Shaft Overhung Load kgf/lbs	S.F.		H	V
0.2	1/4	02	6.12/531.22	340/748	1.80	5.10/442.68	340/748	1.80	02-808-51	225	225

Ratio	Frequency	Motor Input Speed	Reducer Output Speed
51	50Hz	1500rpm	29rpm
	60Hz	1800rpm	35rpm

MOTOR			50Hz			60Hz			TRANSCYKO MODEL	Dimension Page	
kW	HP	Symbol	Output Torque kgf.m/in.lbs	Allowable Output Shaft Overhung Load kgf/lbs	S.F.	Output Torque kgf.m/in.lbs	Allowable Output Shaft Overhung Load kgf/lbs	S.F.		H	V
0.2	1/4	02	6.12/531.22	340/748	1.80	5.10/442.68	340/748	1.80	02-808-51	225	225

## Selection Tables For 808 Speed Reducers

Input Speed (rpm)	Ratio	Frame Size 808	1800		1500		1200		1000		900		750		600		50 and Below	Dimension Page	
			Input KW/HP	Output torque kgf.m/in.lbs	Input KW/HP	Output torque kgf.m/in.lbs	Input KW/HP	Output torque kgf.m/in.lbs	Input KW/HP	Output torque kgf.m/in.lbs	Input KW/HP	Output torque kgf.m/in.lbs	Input KW/HP	Output torque kgf.m/in.lbs	Input KW/HP	Output torque kgf.m/in.lbs		Output torque kgf.m/in.lbs	H
6	Output Speed rpm	300	0.78/1.05	2.47/214.40	0.78/1.05	2.98/258.66	0.78/1.05	3.70/321.16	0.78/1.05	4.40/381.92	0.78/1.05	4.96/430.53	0.78/1.05	5.99/519.93	0.78/1.05	7.44/645.79	2/173.6	226	226
			0.78/1.05	2.25/198.00	0.78/1.05	2.88/250.00	0.78/1.05	3.50/303.00	0.78/1.05	4.12/357.00	0.78/1.05	4.74/414.00	0.78/1.05	5.36/468.00	0.78/1.05	6.39/554.00	0.78/1.05	7.84/678.00	2/173.6
8	Output Speed rpm	225	0.78/1.05	3.29/285.57	0.78/1.05	3.97/344.60	0.78/1.05	4.49/389.73	0.78/1.05	5.87/509.52	0.78/1.05	6.62/574.62	0.78/1.05	7.99/693.53	0.78/1.05	9.92/861.06	10.10/885.36	226	226
			0.78/1.05	2.92/253.00	0.78/1.05	3.54/308.00	0.78/1.05	4.06/357.00	0.78/1.05	4.68/406.00	0.78/1.05	5.30/455.00	0.78/1.05	5.92/504.00	0.78/1.05	7.04/604.00	0.78/1.05	8.68/754.00	10.10/885.36
11	Output Speed rpm	164	0.78/1.05	4.53/393.20	0.78/1.05	5.45/473.06	0.78/1.05	6.79/589.37	0.78/1.05	8.07/700.48	0.78/1.05	9.06/786.41	0.68/0.91	9.65/873.62	0.58/0.78	10.2/885.36	10.20/885.36	226	226
			0.78/1.05	4.06/357.00	0.78/1.05	4.88/421.00	0.78/1.05	6.00/525.00	0.78/1.05	7.12/621.00	0.78/1.05	8.24/721.00	0.78/1.05	9.36/821.00	0.68/0.91	9.92/861.06	0.58/0.78	10.2/885.36	10.20/885.36
13	Output Speed rpm	138	0.78/1.05	5.34/463.51	0.78/1.05	6.45/559.86	0.78/1.05	8.02/696.14	0.78/1.05	9.54/828.07	0.74/0.99	10.2/885.36	0.61/0.82	10.2/885.36	0.49/0.66	10.2/885.36	10.20/885.36	226	226
			0.78/1.05	4.88/421.00	0.78/1.05	5.80/504.00	0.78/1.05	7.12/621.00	0.78/1.05	8.44/731.00	0.78/1.05	9.76/841.00	0.78/1.05	10.2/885.36	0.61/0.82	10.2/885.36	0.49/0.66	10.2/885.36	10.20/885.36
15	Output Speed rpm	120	0.78/1.05	6.98/605.86	0.78/1.05	7.44/645.79	0.78/1.05	9.26/803.77	0.72/0.96	10.2/885.36	0.64/0.86	10.2/885.36	0.53/0.71	10.2/885.36	0.43/0.58	10.2/885.36	10.20/885.36	226	226
			0.78/1.05	6.11/530.35	0.78/1.05	8.43/731.72	0.76/1.02	10.2/885.36	0.64/0.86	10.2/885.36	0.56/0.75	10.2/885.36	0.47/0.63	10.2/885.36	0.38/0.51	10.2/885.36	10.20/885.36	226	226
17	Output Speed rpm	106	0.78/1.05	6.11/530.35	0.78/1.05	8.43/731.72	0.76/1.02	10.2/885.36	0.64/0.86	10.2/885.36	0.56/0.75	10.2/885.36	0.47/0.63	10.2/885.36	0.38/0.51	10.2/885.36	10.20/885.36	226	226
			0.55/0.74	6.11/530.35	0.55/0.74	7.73/670.96	0.47/0.63	7.87/683.12	0.40/0.54	7.87/683.12	0.35/0.47	7.87/683.12	0.29/0.39	7.87/683.12	0.24/0.32	7.87/683.12	7.87/683.12	226	226
21	Output Speed rpm	86	0.55/0.74	6.11/530.35	0.55/0.74	7.73/670.96	0.47/0.63	7.87/683.12	0.40/0.54	7.87/683.12	0.35/0.47	7.87/683.12	0.29/0.39	7.87/683.12	0.24/0.32	7.87/683.12	7.87/683.12	226	226
			0.48/0.64	6.27/544.24	0.48/0.64	7.57/657.08	0.47/0.63	9.42/817.66	0.43/0.58	10.2/885.36	0.38/0.51	10.2/885.36	0.32/0.43	10.2/885.36	0.26/0.35	10.2/885.36	10.20/885.36	226	226
25	Output Speed rpm	72	0.48/0.64	6.27/544.24	0.48/0.64	7.57/657.08	0.47/0.63	9.42/817.66	0.43/0.58	10.2/885.36	0.38/0.51	10.2/885.36	0.32/0.43	10.2/885.36	0.26/0.35	10.2/885.36	10.20/885.36	226	226
			0.47/0.63	7.16/621.49	0.47/0.63	8.64/749.95	0.44/0.59	10.2/885.36	0.37/0.50	10.2/885.36	0.33/0.44	10.2/885.36	0.27/0.36	10.2/885.36	0.22/0.24	10.2/885.36	10.20/885.36	226	226
29	Output Speed rpm	62	0.47/0.63	7.16/621.49	0.47/0.63	8.64/749.95	0.44/0.59	10.2/885.36	0.37/0.50	10.2/885.36	0.33/0.44	10.2/885.36	0.27/0.36	10.2/885.36	0.22/0.24	10.2/885.36	10.20/885.36	226	226
			0.47/0.63	6.84/749.95	0.41/0.55	9.19/797.69	0.36/0.48	9.90/859.32	0.31/0.42	10.2/885.36	0.27/0.36	10.2/885.36	0.23/0.31	10.2/885.36	0.18/0.24	10.2/885.36	10.20/885.36	226	226
35	Output Speed rpm	51	0.47/0.63	6.84/749.95	0.41/0.55	9.19/797.69	0.36/0.48	9.90/859.32	0.31/0.42	10.2/885.36	0.27/0.36	10.2/885.36	0.23/0.31	10.2/885.36	0.18/0.24	10.2/885.36	10.20/885.36	226	226
			0.29/0.39	6.68/579.82	0.29/0.39	8.06/699.61	0.29/0.39	10.0/868.00	0.25/0.34	10.2/885.36	0.22/0.29	10.2/885.36	0.19/0.25	10.2/885.36	0.15/0.20	10.2/885.36	10.20/885.36	226	226
43	Output Speed rpm	51	0.29/0.39	6.68/579.82	0.29/0.39	8.06/699.61	0.29/0.39	10.0/868.00	0.25/0.34	10.2/885.36	0.22/0.29	10.2/885.36	0.19/0.25	10.2/885.36	0.15/0.20	10.2/885.36	10.20/885.36	226	226
			0.24/0.32	6.49/563.33	0.24/0.32	7.84/680.51	0.24/0.32	9.77/848.04	0.21/0.28	10.2/885.36	0.19/0.25	10.2/885.36	0.16/0.21	10.2/885.36	0.13/0.17	10.2/885.36	10.0/868.00	226	226
51	Output Speed rpm	35	0.24/0.32	6.49/563.33	0.24/0.32	7.84/680.51	0.24/0.32	9.77/848.04	0.21/0.28	10.2/885.36	0.19/0.25	10.2/885.36	0.16/0.21	10.2/885.36	0.13/0.17	10.2/885.36	10.0/868.00	226	226
			0.23/0.31	7.28/631.90	0.23/0.31	8.79/762.97	0.22/0.29	10.2/885.36	0.18/0.24	10.2/885.36	0.16/0.21	10.2/885.36	0.14/0.19	10.2/885.36	0.11/0.15	10.2/885.36	10.0/868.00	226	226
59	Output Speed rpm	31	0.23/0.31	7.28/631.90	0.23/0.31	8.79/762.97	0.22/0.29	10.2/885.36	0.18/0.24	10.2/885.36	0.16/0.21	10.2/885.36	0.14/0.19	10.2/885.36	0.11/0.15	10.2/885.36	10.0/868.00	226	226
			0.20/0.27	7.58/657.94	0.20/0.27	9.14/793.35	0.18/0.24	10.2/885.36	0.15/0.20	10.2/885.36	0.14/0.19	10.2/885.36	0.11/0.15	10.2/885.36	0.09/0.12	10.2/885.36	10.0/868.00	226	226
71	Output Speed rpm	25	0.20/0.27	7.58/657.94	0.20/0.27	9.14/793.35	0.18/0.24	10.2/885.36	0.15/0.20	10.2/885.36	0.14/0.19	10.2/885.36	0.11/0.15	10.2/885.36	0.09/0.12	10.2/885.36	10.0/868.00	226	226
			0.12/0.16	5.58/484.34	0.12/0.16	6.73/584.16	0.12/0.16	8.37/726.52	0.12/0.16	9.95/863.66	0.11/0.15	10.2/885.36	0.09/0.12	10.2/885.36	0.07/0.09	10.2/885.36	10.0/868.00	226	226
87	Output Speed rpm	21	0.12/0.16	5.58/484.34	0.12/0.16	6.73/584.16	0.12/0.16	8.37/726.52	0.12/0.16	9.95/863.66	0.11/0.15	10.2/885.36	0.09/0.12	10.2/885.36	0.07/0.09	10.2/885.36	10.0/868.00	226	226
			0.12/0.16	5.58/484.34	0.12/0.16	6.73/584.16	0.12/0.16	8.37/726.52	0.12/0.16	9.95/863.66	0.11/0.15	10.2/885.36	0.09/0.12	10.2/885.36	0.07/0.09	10.2/885.36	10.0/868.00	226	226



# DIMENSION OF T□□C-6□□

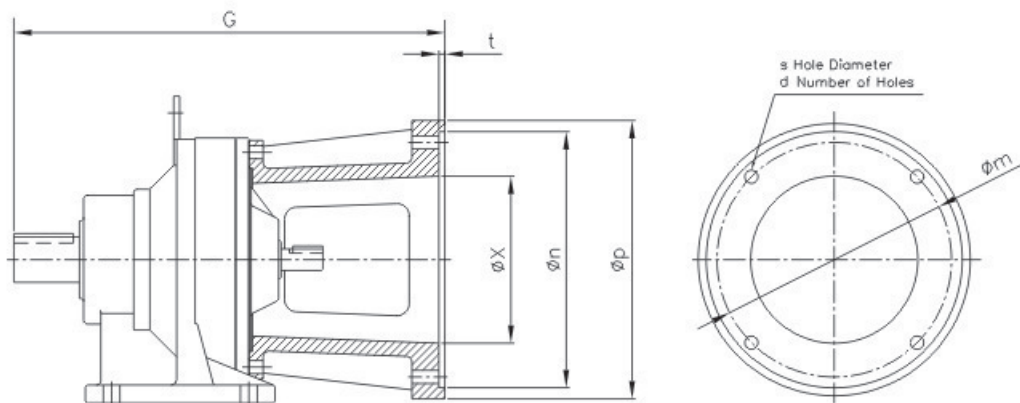

Reducer Model No.	Motor Model No.	G	x	n	p	d	m	s	t
609	42C	9.73	3.31	3.00	4.33	4	3.75	0.28	0
609	48C	10.11	3.31	3.00	4.33	4	3.75	0.28	0
609	56C 145TC	10.50	3.50	4.50	6.69	4	5.88	0.43	0
610	48C	10.32	3.23	3.00	4.33	4	3.75	0.28	0
610	56C 145TC	10.81	3.50	4.50	6.69	4	5.88	0.43	0
610	182TC 184TC	11.31	3.50	8.50	8.98	4	7.25	0.59	0.22
611	56C 145TC	12.81	5.04	4.50	6.69	4	5.88	0.43	0
611	182TC 184TC	13.79	5.49	8.50	8.98	4	7.25	0.59	0.22
611	213TC 215TC	14.39	5.06	8.50	8.98	4	7.25	0.59	0.22
612	56C 145TC	12.81	5.04	4.50	6.69	4	5.88	0.43	0
612	145TC 182TC	13.79	5.49	8.50	8.98	4	7.25	0.59	0.22
612	213TC 215TC	14.39	5.49	8.50	8.98	4	7.25	0.59	0.22
613	56C 145TC	15.25	5.04	4.50	6.69	4	5.88	0.43	0
613	182TC 184TC	16.28	4.88	8.50	8.98	4	7.25	0.59	0.22
613	213TC 215TC	16.62	5.12	8.50	8.98	4	7.25	0.59	0.22
613	254TC 256TC	17.66	5.51	8.50	8.98	4	7.25	0.59	0.22
614	56C 145TC	16.04	5.04	4.50	6.69	4	5.88	0.43	0
614	182TC 184TC	17.07	4.88	8.50	8.98	4	7.25	0.59	0.22
614	213TC 215TC	17.41	5.12	8.50	8.98	4	7.25	0.59	0.22
614	254TC 256TC	18.45	5.51	8.50	8.98	4	7.25	0.59	0.22
615	56C 145TC	16.04	5.04	4.50	6.69	4	5.88	0.43	0
615	182TC 184TC	17.07	4.88	8.50	8.98	4	7.25	0.59	0.22
615	213TC 215TC	17.41	5.12	8.50	8.98	4	7.25	0.59	0.22
615	254TC 256TC	18.45	5.51	8.50	8.98	4	7.25	0.59	0.22



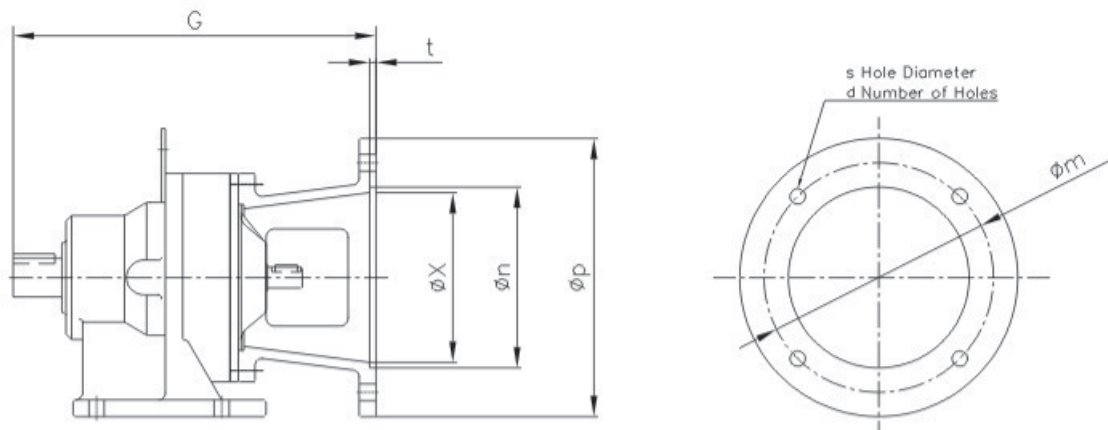

Reducer Model No.	Motor Model No.	G	x	m	n	p	t	s	d
609	71	242	102.3	130	110	160	5	10	4
609	90L	255	122	165	130	200	5	12	4
610	80L	251	122	165	130	200	5	12	4
611	90L	312	128	165	130	200	5	12	4
611	100L	322	164	215	180	250	6	12	4
612	90L	312	128	165	130	200	5	12	4
612	100L	322	164	215	180	250	6	12	4
613	90L	374	114	165	130	200	5	12	4
616	90L	466	140	165	130	200	5	12	4
616	132M	496	203	265	230	300	6	15	4
616	160M	526	220	300	250	350	7	19	4
617	180M	591	260	350	300	400	7	19	4
619	132M	705.5	195	265	230	300	6	15	4
619	160M	735.5	228	300	250	350	7	19	4
619	180M	736.5	280	350	300	400	7	19	4
619	200L	736.5	330	400	350	450	7	19	8
620	160M	791	237	300	250	350	7	19	4
620	180M	791	280	350	300	400	7	19	4
620	200L	821	280	350	300	400	7	19	4
621	160M	820	235	300	250	350	7	19	4
621	180M	821	275	350	300	400	7	19	4
621	200L	851	325	400	350	450	7	19	8
621	225S	851	376	500	450	550	7	19	8
622	180M	866	275	350	300	400	7	19	4
622	200L	896	325	400	350	450	7	19	8
622	225S	897	354	500	450	550	7	19	8
623	180M	953	275	350	300	400	7	19	4
623	200L	984	325	400	350	450	7	19	8
623	225S	984	380	500	450	550	7	19	8
624	225S	1022	425	500	450	550	7	19	8
625	225S	1185	424	500	450	550	7	19	8
626	225S	1295	424	500	450	550	7	19	8

# DIMENSION OF T □□X-6□□(IEC/NEMA INPUT HOLLOW SHAFT ADAPTERS)

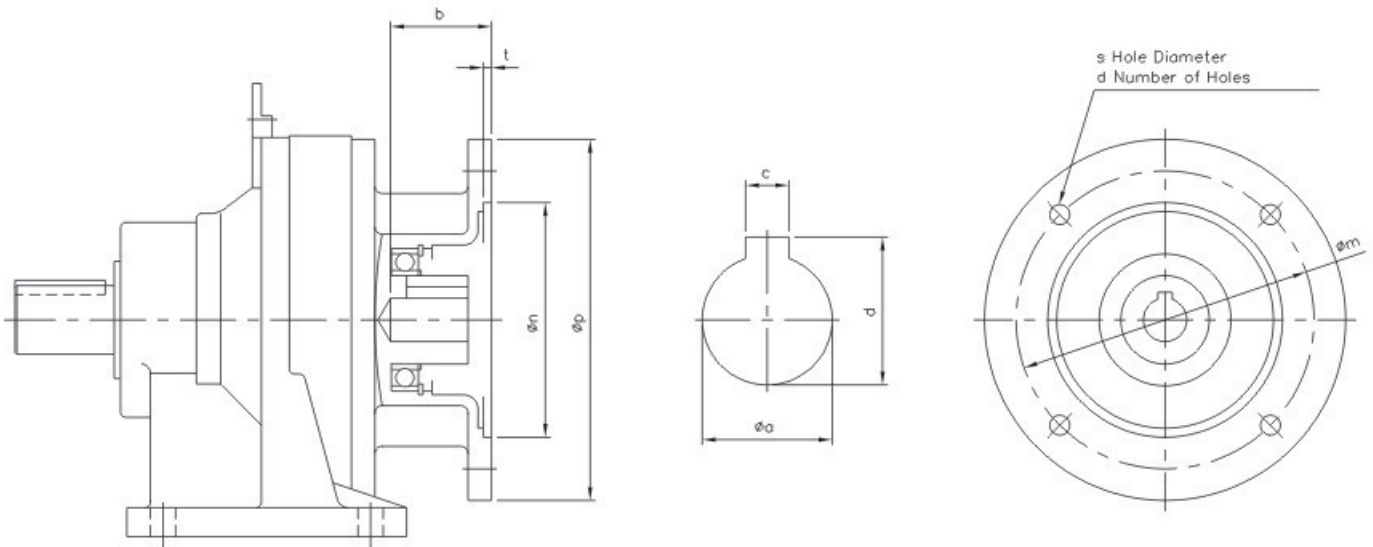

For IEC Motor ( mm )

Frame No.	m	n	p	t	s	a	b	c	d
63	130	110	160	4.5	9	11	23	4	12.8
71	130	110	160	4.5	9	14	30	5	16.3
80	165	130	200	4.5	11	19	40	6	21.8
90L	165	130	200	4.5	11	24	50	8	27.3
110L,112L	215	180	250	5	14	28	60	8	31.3
132S,132S	265	230	300	5	14	38	80	10	41.3
160M,160L	300	230	350	6	18	42	110	12	45.3

For NEM Motor ( in )

Frame No.	m	n	p	t	s	a	KEYWAY
56C	5.88	4.50	6.69	0.20	0.43	0.625 ± $\begin{smallmatrix} 0.0007 \\ 0.0000 \end{smallmatrix}$	3/16 × 3/32
143-145TC	5.88	4.50	6.69	0.20	0.43	0.875 ± $\begin{smallmatrix} 0.0008 \\ 0.0000 \end{smallmatrix}$	3/16 × 3/32

## DIMENSION OF T□□T-6□□ TOP MOUNT ADAPTERS

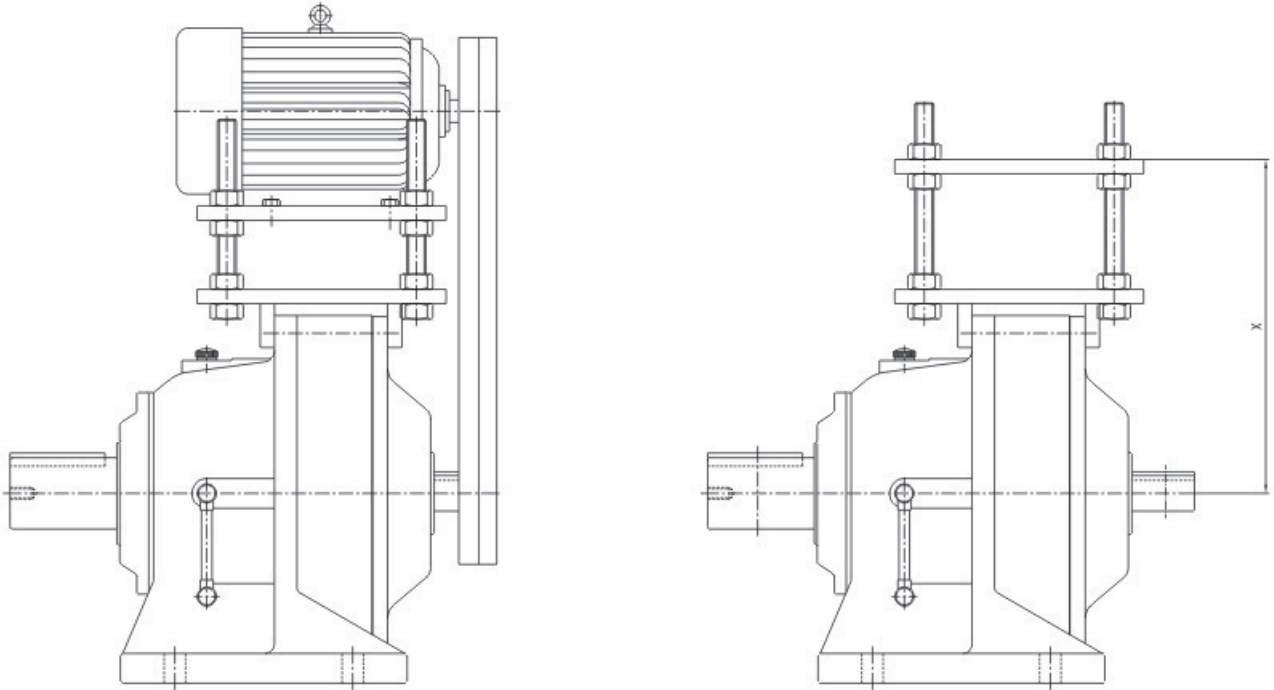

use simple adjusting screws for belt tensioning, this table shows the approximately adjustable range of "X" dimensions. (mm/in)

TRANSCYKO		611,612	613,614,615	616	617	618
"X" dimension	Min.	190/7.50	184/7.25	226/8.88	257/10.13	270/10.63
	Max.	254/10.00	260/10.25	302/11.88	334/13.13	346/13.63

TRANSCYKO		619	620	621	622	623
"X" dimension	Min.	305/12.00	337/13.25	353/13.90	370/14.56	387/15.25
	Max.	381/15.00	413/16.25	429/16.90	446/17.56	464/18.25

TRANSCYKO		624	625	626	627
"X" dimension	Min.	411/16.18	476/18.75	500/19.68	584/23.00
	Max.	487/19.18	552/21.75	576/22.68	660/26.00



# ALLOWABLE OVERHUNG LOAD

When a gear, sprocket, sheave or other pullers is coupled to the slow speed shaft (output shaft), it is very important to make sure the applied overhung load on the slow speed shaft is within the range of the allowable overhung load. Please confirm the overhung load on the slow speed shaft with the following formula:

$$\text{Actual Overhung Load} = \frac{T_i}{R} \leq \frac{\text{Allowable Overhung Load}}{L_f \times C_f \times F_s}$$

$T_i$ : Actual Transmitted torque on slow speed shaft.

$R$ : Pitch circle radius of sprocket, gear, pulley, etc.

$L_f$ : Load location factor.

$C_f$ : Coupling factor.

$F_s$ : Shock factor.

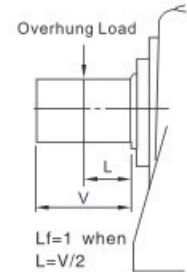

## Coupling factor $C_f$

Type of coupling	$C_f$
Chain	1
Gears	1.2
V-Belt	1.5
Flat Belt	2.5

## Shock factor $F_s$

Degree Shock	$F_s$
No shock	1
Light shock	1~1.2
Severe shock	1.4~1.6

## Load Location factor $L_f$

Frame size	L mm																													
	in		5	10	15	20	25	30	35	40	45	50	60	70	80	90	100	120	140	160	180	200	225	250	275	300				
			0.2	0.4	0.6	0.8	1.0	1.2	1.4	1.6	1.8	2.0	2.4	2.8	3.1	3.5	4.0	4.7	5.5	6.3	7.0	8.0	9.0	10.0	11.0	12.0				
607			0.83	0.94	1.19	1.56																								
608			0.82	0.91	1.00	1.29	1.59	1.88																						
609			0.86	0.92	0.97	1.13	1.38	1.64	1.90																					
610			0.86	0.92	0.97	1.13	1.38	1.64	1.90																					
611				0.82	0.87	0.92	0.97	1.08	1.25	1.42	1.59	1.76																		
612																														
613					0.83	0.87	0.92	0.96	1.00	1.13	1.25	1.38	1.63	1.88																
614						0.66	0.73	0.80	0.87	0.93	1.00	1.10	1.30	1.50	1.70	1.90														
615																														
616						0.83	0.87	0.90	0.93	0.97	1.00	1.11	1.32	1.53	1.75	1.96														
617						0.86	0.89	0.92	0.94	0.97	1.00	1.11	1.32	1.53	1.75	1.96														
618							0.85	0.87	0.90	0.93	0.95	0.98	1.09	1.26	1.43	1.60	1.78													
619								0.89	0.87	0.89	0.91	0.93	0.97	1.04	1.18	1.32	1.46	1.75												
620									0.85		0.70	0.74	0.77	0.84	0.91	0.98	1.05	1.12	1.26	1.40	1.54									
621											0.70	0.73	0.77	0.84	0.91	0.98	1.05	1.13	1.27	1.41	1.56									
622												0.86	0.88	0.90	0.93	0.96	0.99	1.02	1.06	1.12	1.19	1.25								
623													0.82	0.84	0.85	0.88	0.91	0.94	0.97	1.00	1.06	1.12	1.18	1.24	1.30					
624														0.83	0.84	0.86	0.89	0.92	0.94	0.97	1.00	1.06	1.11	1.17	1.23	1.29				
625															0.83	0.85	0.88	0.90	0.93	0.95	1.00	1.05	1.10	1.22	1.36	1.52	1.69			
626																0.83	0.85	0.88	0.90	0.94	0.98	1.04	1.17	1.29	1.45	1.61	1.77	1.93		
627																		0.71	0.75	0.82	0.90	0.98	1.09	1.21	1.35	1.50	1.65	1.79		

Allowable Slow Speed Shaft Overhung Load Capacity For Standard Units ( $\frac{\text{kgf}}{\text{lbs}}$ ) (Cf,Lf,Fs=1)

Output speed Frame size RPM	< 2	3	4	5	6	8	10	15	20	25	30	35	40	50	60	80	100	125	150	200	250	300
607	110 242	110 242	110 242	110 242	110 242	110 242	110 242	110 242	110 242	110 242	110 242	110 242	110 242	110 242	110 242	110 242	110 242	105 231	95 209	85 187		
608	180 396	180 396	180 396	180 396	180 396	180 396	180 396	180 396	180 396	180 396	180 396	180 396	180 396	180 396	180 396	180 396	180 396	175 385	165 363	150 330	140 308	130 286
609	340 748	340 748	340 748	340 748	340 748	340 748	340 748	340 748	340 748	340 748	340 748	340 748	340 748	340 748	340 748	340 748	340 748	330 726	320 704	282 620	262 576	248 546
610	550 1210	550 1210	550 1210	550 1210	550 1210	550 1210	550 1210	550 1210	550 1210	550 1210	550 1210	550 1210	550 1210	550 1210	550 1210	550 1210	550 1210	520 1144	490 1078	443 975	415 913	390 858
611	880 1963	880 1963	880 1963	880 1936	880 1936	880 1936	880 1936	880 1936	880 1936	880 1936	880 1936	880 1936	880 1936	880 1936	835 1837	750 1665	750 1551	654 1439	615 1353	557 1225	516 1135	487 1071
612	1000 2000	1000 2200	1000 2200	1000 2200	1000 2200	1000 2200	1000 2200	1000 2200	1000 2200	1000 2200	1000 2200	1000 2200	955 2101	889 1956	835 1837	760 1672	705 1551	655 1441	615 1353	560 1232	519 1142	487 1071
613	1365 3003	1365 3003	1365 3003	1365 3003	1365 3003	1365 3003	1365 3003	1365 3003	1360 2992	1295 2849	1220 2684	1150 2530	1110 2442	1030 2266	965 2123	880 1936	818 1800	758 1668	715 1573	647 1423	601 1322	568 1250
614	1500 3300	1500 3300	1500 3300	1500 3300	1500 3300	1500 3300	1500 3300	1500 3300	1500 3300	1500 3300	1460 3213	1405 3091	1315 2893	1242 2732	1141 2510	1060 2332	995 2189	940 2068	862 1896	810 1782	765 1683	
615	1600 3520	1600 3520	1600 3520	1600 3520	1600 3520	1600 3520	1600 3520	1600 3520	1600 3520	1600 3520	1600 3520	1600 3520	1600 3520	1532 3370	1453 3197	1330 2926	1241 2730	1162 2556	1100 2420	1010 2222	940 2068	890 1958
616	2050 4510	2050 4510	2050 4510	2050 4510	2050 4510	2050 4510	2050 4510	2000 4400	2000 4400	1985 4367	1880 4136	1805 3971	1680 3696	1580 3476	1432 3150	1333 2933	1230 2706	1165 2563	1050 2310	975 2145	920 2024	
617	2900 6380	2900 6380	2900 6380	2900 6380	2900 6380	2900 6380	2900 6380	2680 5896	2490 5478	2340 5148	2220 4884	2120 4664	1970 4334	1855 4081	1685 3707	1565 3443	1450 3190	1365 3003	1242 2732	1152 2534	1081 2378	
618	4000 8800	4400 8800	4000 8800	4000 8800	4000 8800	3900 8580	3800 8360	3590 7898	3330 7326	3140 6908	2985 6567	2845 6259	2640 5808	2490 5478	2250 4950	2100 4620	1945 4279	1830 4026	1665 3663			
619	5400 11880	5400 11880	5400 11880	5400 11880	5400 11880	5300 11660	5300 11660	5020 11044	4660 10252	4400 9680	4150 9130	3990 8778	3695 8129	3490 7678	3160 6952	2940 6468	2720 5984	2565 5643	2335 5137			
620	8000 17600	8000 17600	8000 17600	8000 17600	8000 17600	8000 17600	7050 15510	6650 14630	6100 13420	5700 12540	5410 11902	5150 11332	4955 10901	4630 10186	4392 9662	4030 8866	3765 8283	3510 7722	3330 7326	3100 6820		
621	8800 19360	8800 19360	8800 19360	8800 19360	8800 19360	8800 19360	8470 18634	7770 17094	7265 15983	6890 15158	6565 14443	6350 13970	5900 12980	5600 12320	5140 11308	4800 10560	4490 9878	4245 9039	3895 8569			
622	14700 32340	14300 31460	13200 29040	17200 25784	17200 25784	10750 23650	10400 22880	8910 19600	8150 17930	7640 16808	7250 15950	6910 15200	6630 14585	6205 13650	5890 12960	5400 11880	5050 11110	4720 10384	4465 9823	4150 9130		
623	18000 39600	18000 39600	16300 35860	14500 31900	14500 31900	13300 29260	12500 27500	11150 24530	10250 22550	9520 20944	9050 19910	8700 19140	8260 18172	7740 17028	7330 16126	6720 14784	6280 13816	5860 12892				
624	21000 46200	19500 42900	18500 40700	16300 35860	16300 35860	15000 33000	14100 31020	12450 27390	11300 24860	10700 23540	10050 22110	9570 21054	9200 20240	8600 18920	8180 17996	7500 16500	6995 15389	6540 14388				
625	26000 57200	24000 52800	22000 48400	19950 43890	19950 43890	18400 40480	17100 37620	15100 33220	14000 30800	13050 28710	12300 27060	11700 25740	11350 24970	10800 23760	9965 21923	9145 20119	8600 18920	8050 17710				
626	27800 61160	27800 61160	27300 60060	24350 53570	24350 53570	22350 49170	20850 45870	18450 40590	16900 37180	15900 34980	15050 33110	14300 31460	13750 30250	12900 28380	12200 26840	11250 24750	10500 23100	9765 21483				
627	20000 44000	20000 44000	20000 44000	20000 44000	20000 44000	20000 44000	20000 44000	20000 44000	20000 44000	20000 44000	20000 44000	20000 44000	20000 44000	20000 44000								

\*For double stage reducers, the overhung load apply to the slow speed output side.



# FORMULA OF DRIVE SYSTEM

## 1. Revolving Speed N(rpm), Velocity V(m/s)

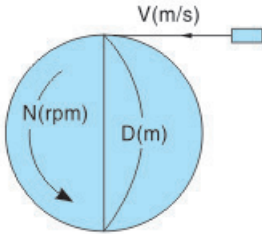

$$V = \pi \cdot D \cdot \frac{N}{60} \text{ (m/s)}$$

D: Wheel Diameter ( m )  
( $\pi=3.14$ )

## 2. Torque T ( kgf.m )

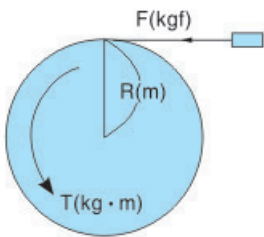

$$T = F \cdot R \cdot \text{ (kgf} \cdot \text{m)}$$

F: Load ( kgf )  
R: Wheel Radius ( m )  
1 kgf · m = 86.8 in · lbs

## 3. Power P ( kW )



$$P = \frac{F \cdot V}{102} \text{ (kw)}$$

F: Load ( kgf )  
V: Velocity ( m/s )  
1HP=0.74569 kw  
1kw=1.341HP

## 4. Power P(kW), Torque T ( kgf.m ) , Revolving Speed N(rpm)

$$P = \frac{N \cdot T}{975} \text{ (kW)}, \quad T = \frac{975 \cdot P}{N} \text{ (kW)}$$

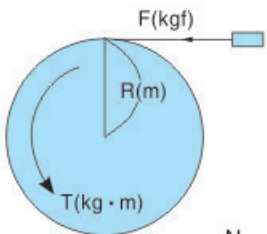

$$P = \frac{F \cdot V}{102} \text{ (kW)}$$

$$V = \pi \cdot 2 \cdot R \cdot \frac{N}{60} \text{ (m/s)}$$

$$\therefore P = \frac{F \cdot \pi \cdot 2 \cdot R \cdot \frac{N}{60}}{102} = \frac{2 \cdot \pi}{102 \times 60} N \cdot F \cdot R \cdot \text{ (kW)}$$

Since  $T = F \cdot R$

$$\therefore P = \frac{2 \cdot \pi}{102 \times 60} \cdot N \cdot T = \frac{N \cdot T}{975} \text{ (kW)}$$

## 5. Acceleration Torque TA ( kgf · m )

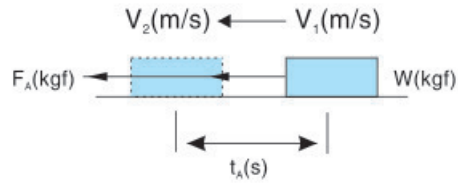

$$F_A = m \cdot a = \frac{W}{g} \cdot \frac{V_2 - V_1}{t_A} \text{ (kgf)}$$

W: Weight ( kgf )  
g: Acceleration of Gravity  
9.8 ( m/s<sup>2</sup> )  
m: Mass ( kgf · s<sup>2</sup>/m )  
a: Acceleration ( m/s<sup>2</sup> )  
t<sub>A</sub>: Acceleration Time ( sec. )

$$m = \frac{W}{g} \text{ (kgf)}, \quad a = \frac{V_2 - V_1}{t_A}$$

## 6. Acceleration Torque TA ( kgf · m )

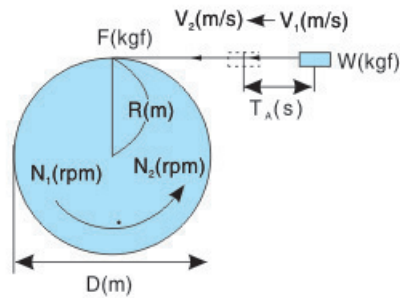

$$T_A = F_A \cdot R, \quad F_A = \frac{W}{g} \cdot \frac{V_2 - V_1}{t_A}$$

$$V_2 = \pi \cdot D \cdot \frac{N_2}{60}, \quad V_1 = \pi \cdot D \cdot \frac{N_1}{60}, \quad R = \frac{D}{2}$$

$$\begin{aligned} \therefore T_A &= \frac{W}{g} \cdot \frac{\pi \cdot D}{60} \cdot \frac{(N_2 - N_1)}{t_A} \cdot \frac{D}{2} \\ &= \frac{\pi \cdot W \cdot D}{60 \cdot g} \cdot \frac{N_2 - N_1}{t_A} \cdot \frac{D}{2} \\ &= \frac{W \cdot D^2}{375} \cdot \frac{N_2 - N_1}{t_A} \text{ (kgf} \cdot \text{m)} \end{aligned}$$

Since  $W \cdot D^2$  is  $GD^2$  (Flywheel Effect): (kgf · m<sup>2</sup>)

$$T_A = \frac{GD^2}{375} \cdot \frac{N_2 - N_1}{t_A} \text{ (kgf} \cdot \text{m)}$$



# Transcyko Global Success Stories

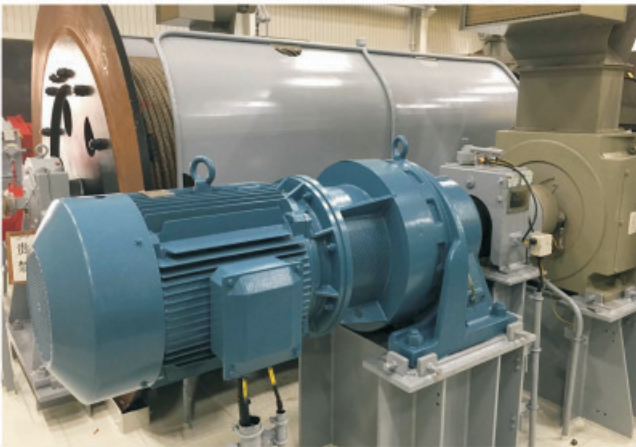



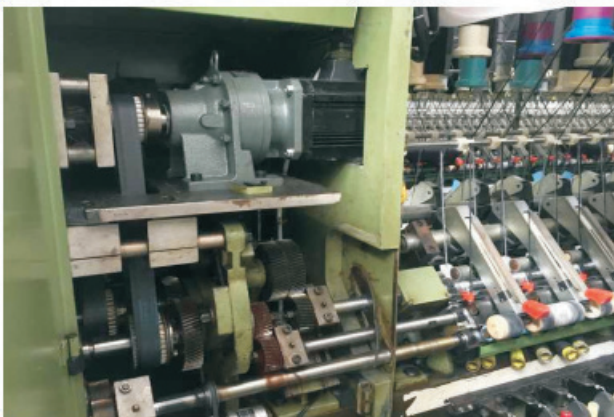
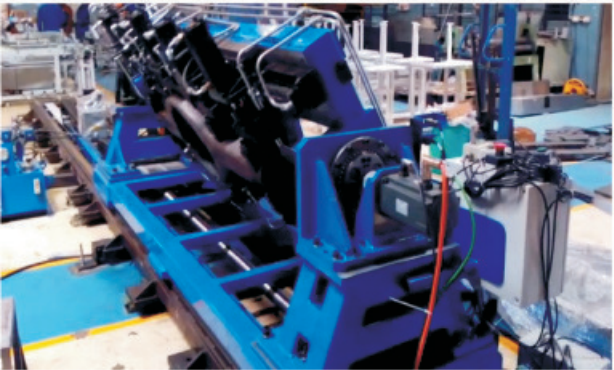



傳仕產品綫

PRODUCT LINE

TR



Helical Gear Motor  
斜齒輪減速馬達

TK

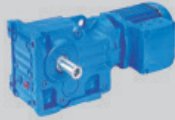

Helical-Bevel Gear Units And Gear Motor  
斜齒輪傘齒輪減速馬達

TSG



Gear Box  
齒輪箱

TSG



TBX



Cycloidal-Bevel Gear Motor  
中空軸齒輪&擺線減速馬達

TBX

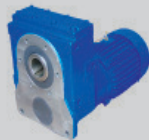

Cycloidal-Helical Gear Motor  
中空軸齒輪&擺線減速馬達

TS



Helical-Worm Gear Unit And Gear Motor  
蝸輪-斜齒輪減速馬達

TP



Planetary Reducer  
行星減速機

TLB



Low backlash reducer  
低背隙減速機

TZS



Centrifugal Reducer  
離心機專用減速機

T600



Cycloid Speed Reducer  
擺線針輪減速馬達

D



Variable Speed Drive  
無段變速馬達



蘇州廠

傳仕重工（蘇州）有限公司

TRANSTEC HEAVY INDUSTRY CO., LTD. (SUZHOU)

地址：中國江蘇省蘇州工業園區勝浦鎮金勝路81號

NO.81 JINSHENG ROAD, SHENGPU TOWN  
SUZHOU INDUSTRIAL PARK, JIANGSU  
PROVINCE, CHINA

TEL:+86-0512-62821756

FAX:+86-0512-62828178

E-mail: 國內 domestic@transcyko-transtec.com

國外 oversea@transcyko-transtec.com

www.transcyko.com



臺灣廠

傳仕精密機械股份有限公司

TRANSMISSION MACHINERY CO., LTD. (TAIWAN)

地址：臺南市善化區小新里士宏新村1-6號74171

NO. 1-6 SHIHONGXINCUN, SHANHUA DIST.,  
TAINAN CITY, TAIWAN 74171

TEL:+886-6-5831177

FAX:+886-6-5831193

E-mail: transtec@ms5.hinet.net

www.transcyko.com