

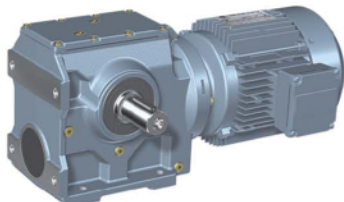

***TR.., TF.., TK.., TS.. Series Gear Motor
Operating Instructions***

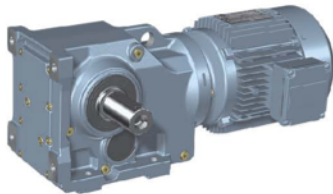

Transmission Machinery Co., Ltd.

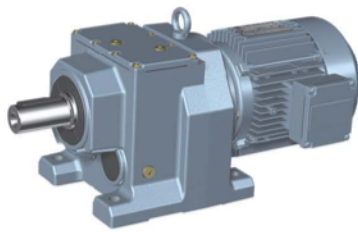



CONTENTS

1	Important Notes	2
2	Safety Notes	3
3	Gear Unit Structure	5
3.1	Basic structure of helical gear units	5
3.2	Basic structure of parallel shaft helical gear units	6
3.3	Basic structure of helical-bevel gear units	7
3.4	Basic structure of helical-worm gear units	8
3.5	Nameplate, unit designation	9
4	Mechanical Installation	10
4.1	Required tools / aids	10
4.2	Prerequisites for assembly	10
4.3	Installing the gear unit	11
4.4	Gear unit with solid shaft	13
4.5	Torque arms for mounted gear units	14
4.6	Mounted gear unit with keyway or splined hollow shaft	15
4.7	Mounted gear units with shrink disc	19
4.8	AM adapter coupling	21
4.9	AD input shaft assembly	23
5	Startup	24
5.1	Startup of helical-worm gear units	24
5.2	Startup of helical, parallel shaft helical and helical-bevel gear units	24
6	Inspection and Maintenance	24
6.1	Inspection and maintenance intervals	24
6.2	Lubricant change intervals	25
6.3	Inspection and maintenance of the gear unit	25
6.4	Inspection / maintenance of AM adapters	26
6.5	Inspection / maintenance of AD adapters	26
7	Malfunctions	27
7.1	Gear unit malfunctions	27
7.2	AM adapter malfunctions	27
7.3	AD input shaft assembly malfunctions	27
8	Mounting Positions	28
8.1	General information on mounting positions	28
8.2	Mounting positions of RX helical gearmotors	29
8.3	Mounting positions for R helical gearmotors	31
8.4	Mounting positions for parallel shaft helical gearmotors	34
8.5	Mounting positions for helical-bevel gearmotors	37
8.6	Mounting positions for helical-worm gearmotors	42
9	Lubricants	48
9.1	Lubricant table	48
9.2	Lubricant fill quantities	49

1. Important Notes

Safety and warning instructions

Always follow the safety and warning instructions in this publication!

	Electrical hazard Possible consequences: Severe or fatal injuries.
	Hazardous situation Possible consequences: Slight or minor injuries.
	Hazard Possible consequences: Severe or fatal injuries.
	Harmful situation Possible consequences: Damage to the drive and the environment.
	Tips and useful information.



In order to operate the product failure-free and guarantee the product quality, please follow this instruction. Before operating the reducer, please read the instruction carefully.

The operating instructions contain important information about servicing. Therefore, keep the operating instructions close to the gear unit.



- Adjust the lubricant fill volume and position of the breather valve accordingly in the event of a change of mounting position (see Sec. "Lubricants" and "Mounting Positions").
- Follow the instructions in Sec. "Mechanical installation" / "Installing the gear unit"!

Waste disposal



Please follow the regulation: dealing with the waste based on waste motor condition and exist regulation:

- Deal with the reducer casing gear, shaft and resistance bearing according to the waste steel, the same as grey cast iron unless having a individual regulation.
- Parts of the worm gears are made of nonas appropriate.
- Collect waste oil and dispose of it correctly.

2. Safety Notes

Preface

The following safety notes are primarily concerned with the use of gear units. If using gearmotors, please also refer to the safety notes for motors in the relevant operating instructions.

Please also consider the supplementary safety notes in the individual sections of these operating instructions.

General information

In / After the period of running, the out surface of the geared motor and reducer may get hot due to the voltage and running part.

Only qualified personnel may carry out the following work:

- Transportation
- Putting into storage
- Installation / assembly
- Connection
- Startup
- Maintenance
- Servicing

The following information and documents must be observed during these processes:

- Relevant operating instructions and wiring diagrams
- Warning and safety signs on the gear unit / gearmotor
- System-specific regulations and requirements
- National / regional regulations governing safety and the prevention of accidents

Serious injuries and property damage may result from:

- Improper use
- Incorrect installation or operation
- Unauthorized removal of necessary protection covers or the housing

Designated use

Gearmotors / gear units are intended for industrial systems. They correspond to the applicable standards and regulations.

Technical data and information about the permitted conditions can be found on the nameplate and in the documentation.

It is essential that you follow all the instructions!

Transportation

Inspect the shipment for any damage that may have occurred in transit as soon as you receive the delivery. Inform the shipping company immediately. It may be that you are not permitted to startup the drive due to the damage.

Tighten installed eyebolts. The eyebolts are only designed for the weight of the gearmotor / gear unit. Do not attach any additional loads.

Use suitable, sufficiently rated handling equipment if necessary. Remove any transportation fixtures prior to startup.

Installation / assembly

Observe the instructions in the sections "Installation" and "Assembly/Removal"!

Startup / operation

Check that the direction of rotation is correct in decoupled status. Listen out for unusual grinding noises as the shaft rotates.

Secure the shaft keys for test mode without drive components. Do not render monitoring and protection equipment inoperative even for test mode.

Switch off the gearmotor if in doubt whenever changes occur in relation to normal operation (e.g. increased temperature, noise, vibration). Determine the cause; contact TONGYU transmission if necessary.

Inspection / maintenance

Follow the instructions in the section "Inspection and Maintenance"!

Extended storage of gear units

Gear units of the "extended storage" type have:

- An oil fill suitable for the mounting position so the unit is ready to run (mineral oil CLP and synthetic oil CLP HC). You should still check the oil level before startup (see Sec. "Inspection / Maintenance" / "Inspection and maintenance of the gear unit").
- A higher oil level in some cases (synthetic oil CLP PG / food grade oil). Correct the oil level before startup (see Sec. "Inspection / Maintenance" / "Inspection and maintenance of the gear unit").

Attention: the life-span of the bearing lubrication will shorten when the reducer reserve more than one year.

Comply with the storage conditions specified in the following table for extended storage:

Climate zone	Packaging ¹⁾	Storage location	Storage time
Temperate (Europe, USA, Canada, China and Russia, excluding tropical zones)	Packed in containers, with desiccant and moisture indicator sealed in the plastic wrap.	With roof, protected against rain and snow, no shock loads.	Up to three years with regular checks on the packaging and moisture indicator (relative atmospheric humidity < 50%).
	Open	With roof, enclosed at constant temperature and atmospheric humidity (5 °C < t < 60 °C, <50 % relative atmospheric humidity). No sudden temperature fluctuations and controlled ventilation with filter (free from dirt and dust). No aggressive vapors and no shock loads.	Two years or more given regular inspections. Check for cleanliness and mechanical damage as part of the inspection. Check corrosion protection.
Tropical (Asia, Africa, Central and South America, Australia, New Zealand excluding temperate zones)	Packed in containers, with desiccant and moisture indicator sealed in the plastic wrap. Protected against insect damage and mildew by chemical treatment.	With roof, protected against rain, no shock loads.	Up to three years with regular checks on the packaging and moisture indicator (relative atmospheric humidity < 50%).
	Open	With roof, enclosed at constant temperature and atmospheric humidity (5 °C < t < 60 °C, <50 % relative atmospheric humidity). No sudden temperature fluctuations and controlled ventilation with filter (free from dirt and dust). No aggressive vapors and no shock loads. Protection against insect damage.	Two years or more given regular inspections. Check for cleanliness and mechanical damage as part of the inspection. Check corrosion protection.

1) Packaging must be performed by an experienced person who has been expressly specified for the particular application.

3. Gear Unit Structure



The following figures are block diagrams. Their purpose is only to make it easier to assign components to the spare parts lists. Discrepancies may occur depending on the gear unit size and version!

3.1 Basic structure of helical gear units

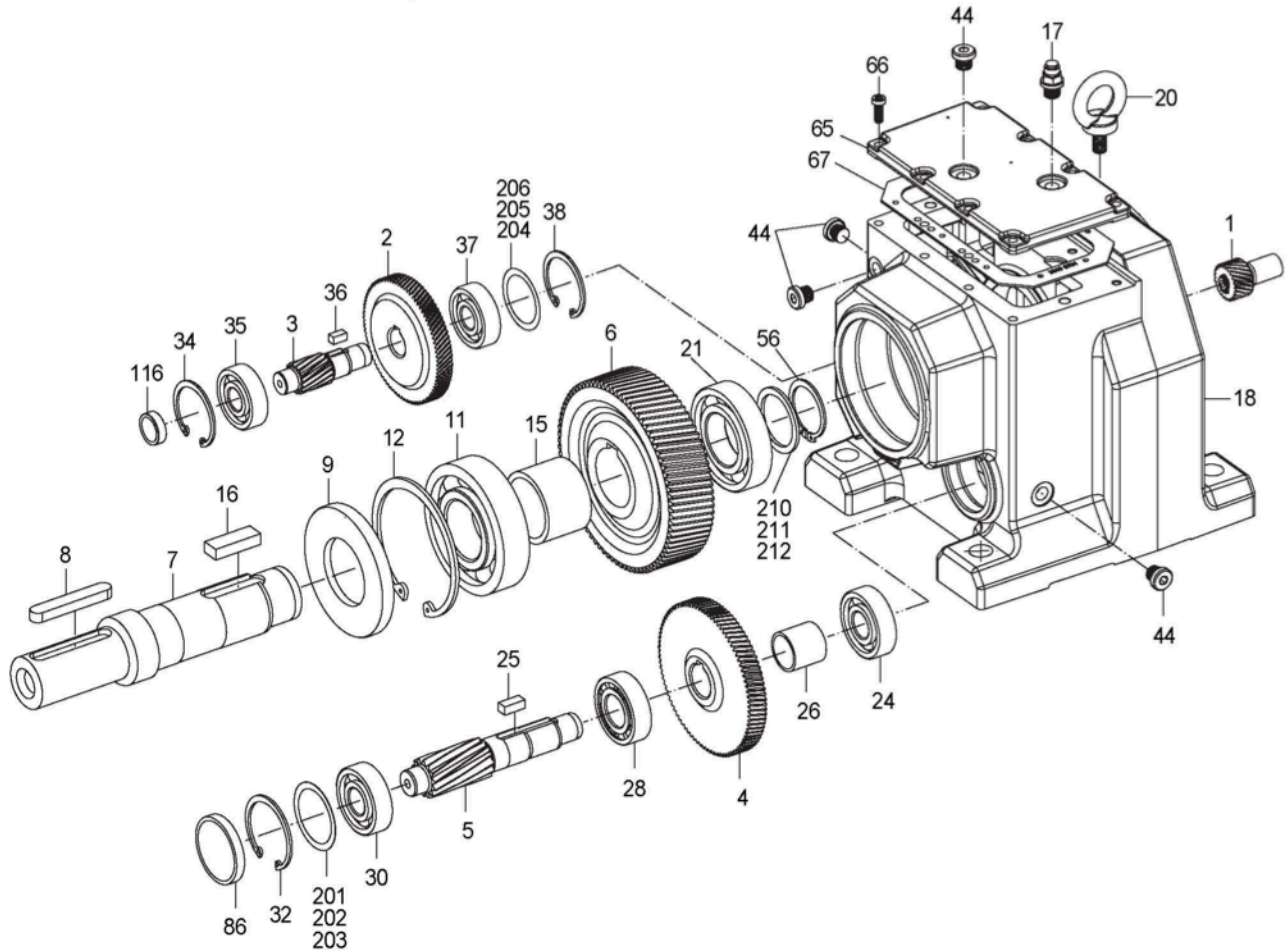

Figure 1: Basic structure of helical gear units

Key

1 Pinion	15 Spacer	32 Circlip	86 Closing cap
2 Gear	16 Key	34 Circlip	116 Closing cap
3 Pinion shaft	17 Breather valve	35 Anti-friction bearing	201 Shim ring
4 Gear	18 Gearcase	36 Key	202 Shim ring
5 Pinion shaft	20 Lifting eyebolt	37 Anti-friction bearing	203 Shim ring
6 Gear	21 Anti-friction bearing	38 Circlip	204 Shim ring
7 Output shaft	24 Anti-friction bearing	44 Screw plug	205 Shim ring
8 Key	25 Key	56 Circlip	206 Shim ring
9 Oil seal	26 Spacer	65 Gearcase cover	210 Shim ring
11 Anti-friction bearing	28 Anti-friction bearing	66 Hex head bolt	211 Shim ring
12 Circlip	30 Anti-friction bearing	67 Gasket	212 Shim ring

3.2 Basicstructure of parallel shaft helical gear units

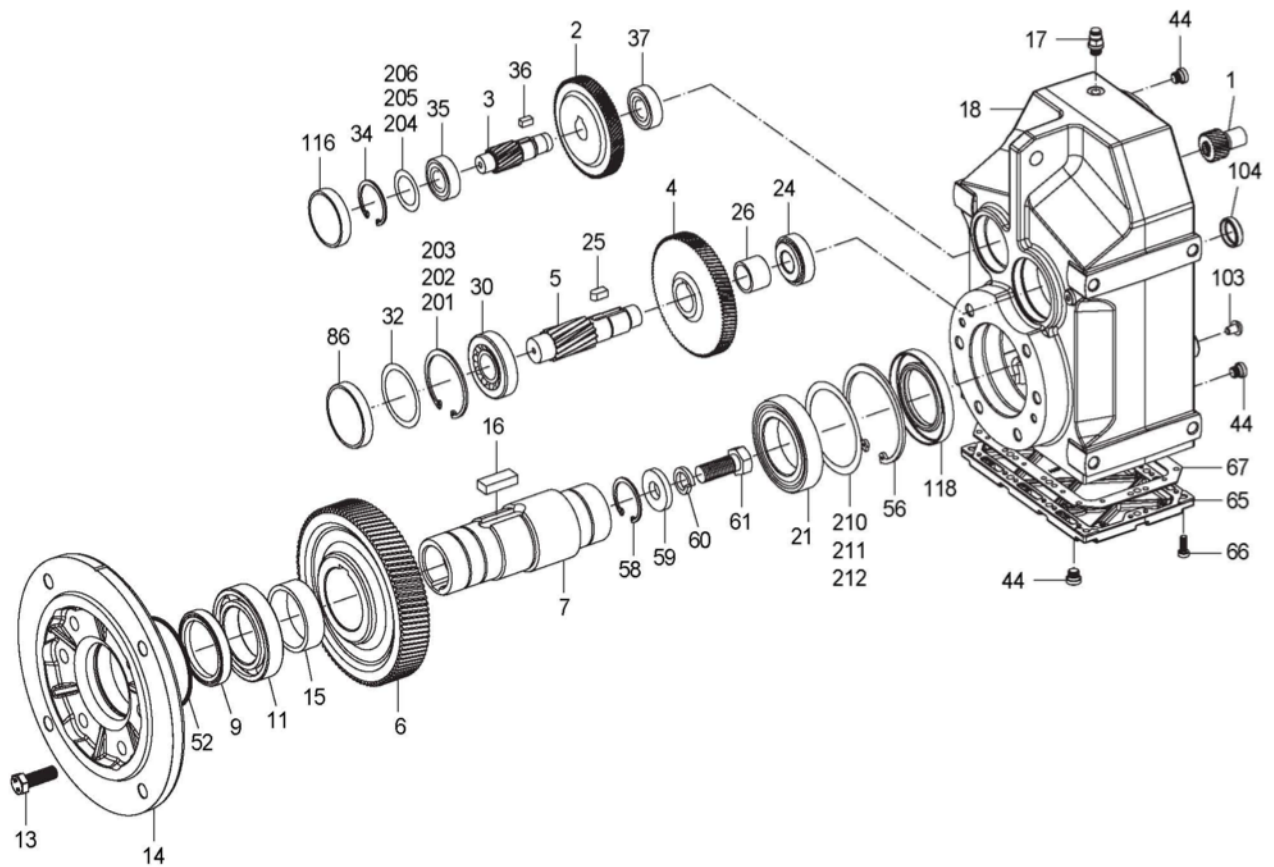

Figure 2: Basic structure of parallel shaft helical gear units

Key

1 Pinion	17 Breather valve	52 O-ring	118 Oil seal
2 Gear	18 Gearcase	56 Circlip	201 Shim ring
3 Pinion shaft	21 Anti-friction bearing	58 Circlip	202 Shim ring
4 Gear	24 Anti-friction bearing	59 Washer	203 Shim ring
5 Pinion shaft	25 Key	60 Lock washer	204 Shim ring
6 Gear	26 Spacer	61 Hex head bolt	205 Shim ring
7 Output shaft	30 Anti-friction bearing	65 Gearcase cover	206 Shim ring
9 Oil seal	32 Circlip	66 Hex head bolt	210 Shim ring
11 Anti-friction bearing	34 Circlip	67 Gasket	211 Shim ring
13 Hex head bolt	35 Anti-friction bearing	86 Closing cap	212 Shim ring
14 Output flange	36 Key	103 Closing plug	
15 Spacer	37 Anti-friction bearing	104 Closing cap	
16 Key	44 Screw plug	116 Closing cap	

3.3 Basic structure of helical-bevel gear units

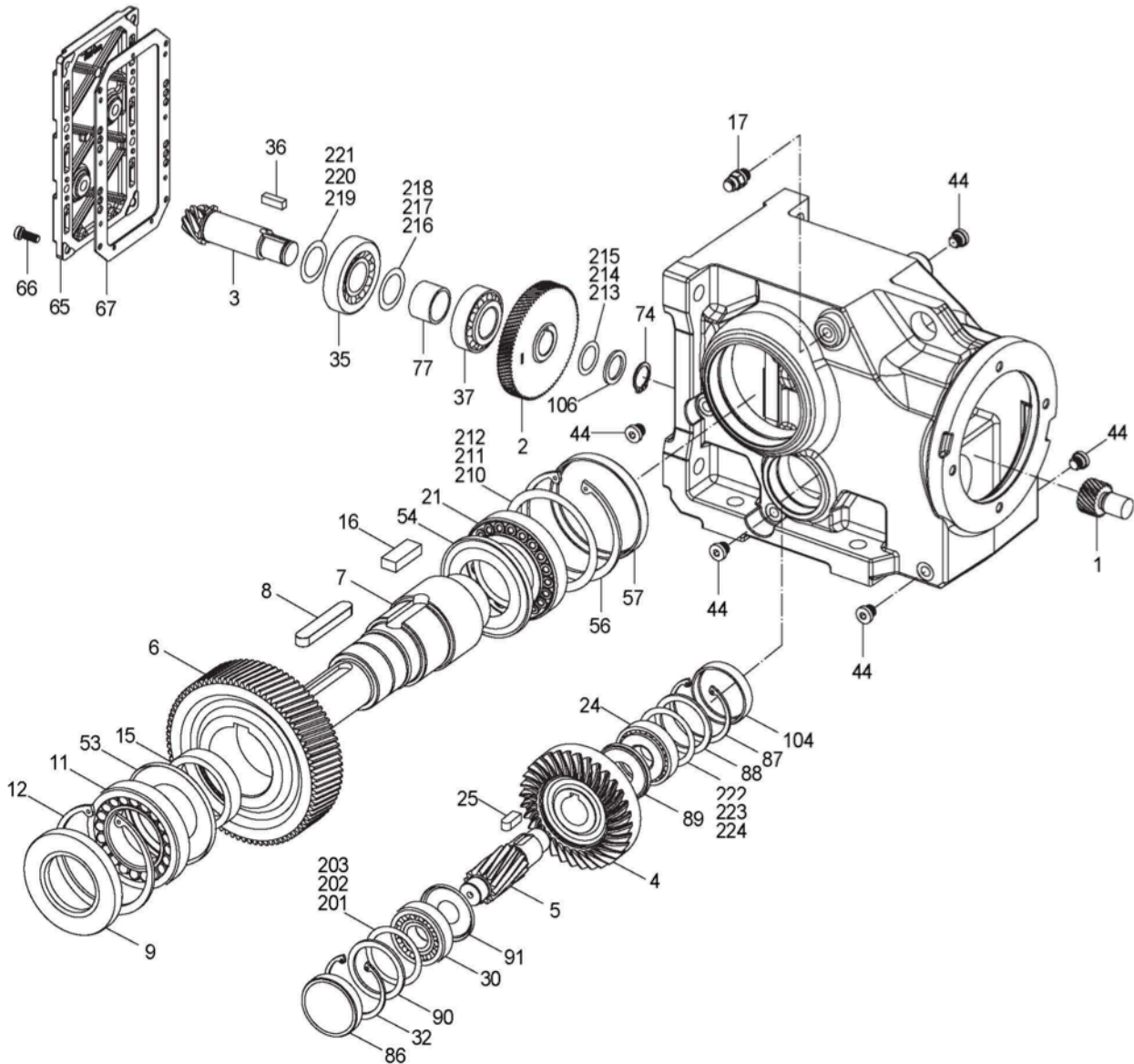

Figure 3: Basic structure of helical-bevel gear units

Key

1	Pinion	18	Gearcase	66	Hex head bolt	211	Shim ring
2	Gear	21	Anti-friction bearing	67	Gasket	212	Shim ring
3	Pinion shaft	24	Anti-friction bearing	74	Circlip	216	Shim ring
4	Gear	25	Key	77	Spacer	217	Shim ring
5	Pinion shaft	30	Anti-friction bearing	86	Closing cap	218	Shim ring
6	Gear	32	Circlip	87	Circlip	219	Shim ring
7	Output shaft	35	Anti-friction bearing	89	Nilos ring	220	Shim ring
8	Key	36	Key	104	Closing cap	221	Shim ring
9	Oil seal	37	Anti-friction bearing	201	Shim ring	222	Shim ring
11	Anti-friction bearing	44	Screw plug	202	Shim ring	223	Shim ring
12	Circlip	53	Nilos ring	203	Shim ring	224	Shim ring
15	Spacer	54	Nilos ring	210	Shim ring		
16	Key	57	Closing cap	211	Shim ring		
17	Breather valve	65	Gearcase cover	212	Shim ring		

3.4 Basic structure of helical-worm gear units

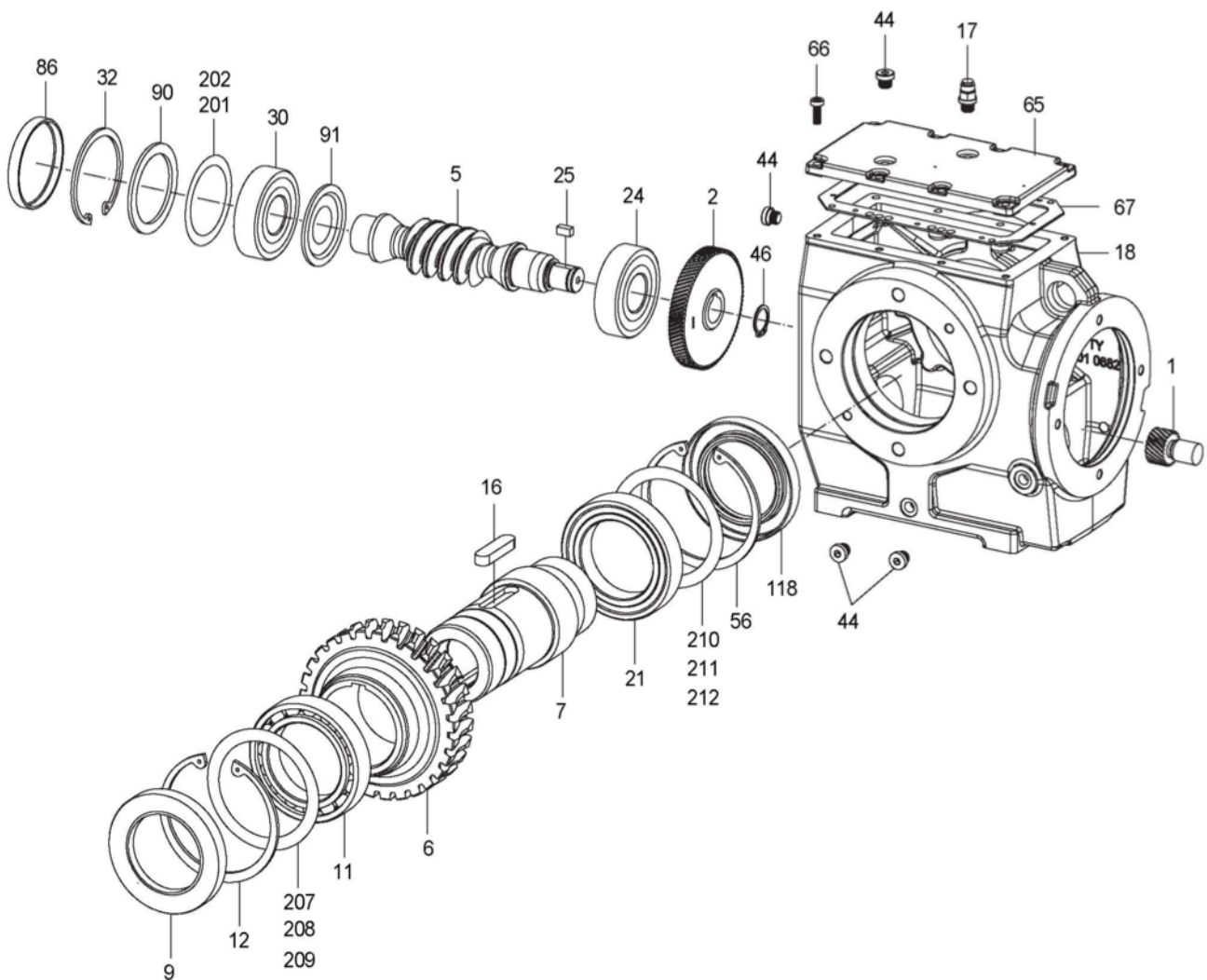

Figure 4: Basic structure of helical-worm gear units

Key

1 Pinion	17 Breather valve	65 Gearcase cover	203 Shim ring
2 Gear	18 Gearcase	66 Hex head bolt	204 Shim ring
5 Pinion shaft	21 Anti-friction bearing	67 Gasket	205 Shim ring
6 Gear	24 Anti-friction bearing	86 Closing cap	206 Shim ring
7 Output shaft	25 Key	90 Washer	210 Shim ring
9 Oil seal	30 Anti-friction bearing	91 Nilos ring	211 Shim ring
11 Anti-friction bearing	32 Circlip	118 Oil seal	212 Shim ring
12 Circlip	44 Screw plug	201 Shim ring	
16 Key	46 Circlip	202 Shim ring	

3.5 Nameplate, unit designation

Sample nameplate



- P_1 [kW] = Rated power driving motor
- n_1 [r/min] = Maximum input speed
- i [Nm] = Gear unit reduction ratio
- M.Pos. = Mounting position
- M_2 [Nm] = Output torque
- n_2 [r/min] = Output speed

Unit designation

Example: Helical gear unit,

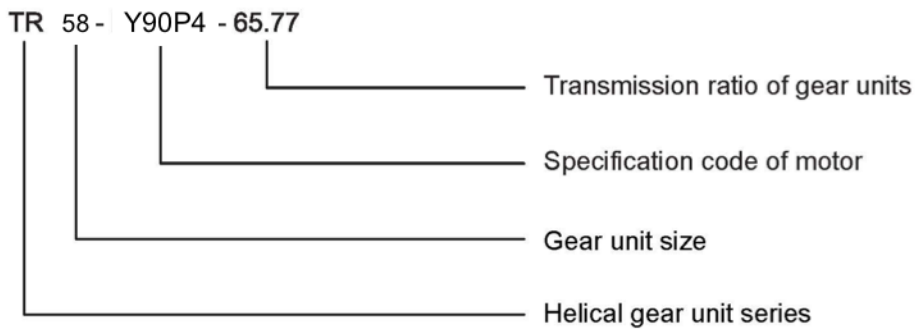

Example: Serial number

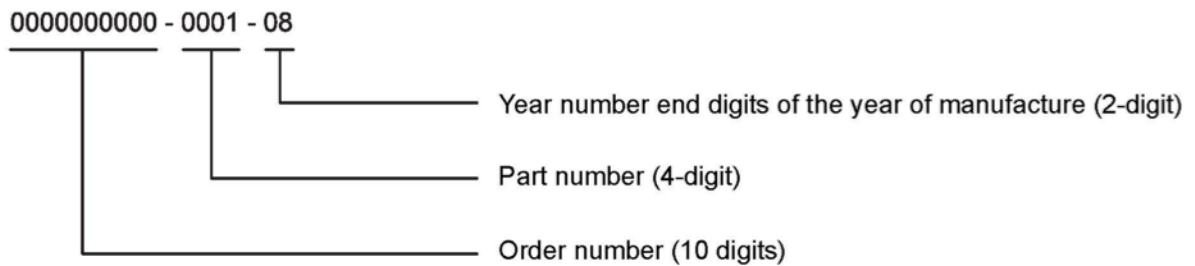

4. Mechanical Installation

4.1 Required tools / aids

Prepare the following tools and spare parts before installation:

- Set of spanners
- Torque wrench for:
 - Shrink discs
 - AM motor adapter
 - Input shaft assembly with centering shoulder
- Mounting device
- Shims and distance rings if necessary
- Fixing devices for input and output elements
- Lubricant
- Standard parts are not part of the delivery

Installation tolerances

Shaft end	Flanges
Diameter tolerance in accordance with DIN 748 <ul style="list-style-type: none"> • ISO k6 for solid shafts with $\Phi \leq 50$ mm • ISO m6 for solid shafts with $\Phi > 50$ mm • ISO H7 for hollow shafts 	Centering shoulder tolerance in accordance with DIN 42948 <ul style="list-style-type: none"> • ISO j6 with $b1 \leq 230$ mm • ISO h6 with $b1 > 230$ mm

4.2 Prerequisites for assembly

Check that the following conditions have been met:

- The data on the nameplate of the gearmotor matches the voltage supply system.
- The drive has not been damaged during transportation or storage.
- Ensure that the following requirements have been met:
 - For standard gear units:

Ambient temperature according to the lubricant table in Sec. "Lubricants" (see standard).

The drive must not be assembled in the following ambient conditions:

- Potentially explosive atmosphere
- Oil
- Acids
- Gas
- Vapors
- Radiation
- For special versions:

The drive configured in accordance with the ambient conditions.

- For helical-worm gear units:

No large external mass moments of inertia which could exert a retrodriving load on the gear unit.

$$[\text{At } \eta' \text{ (retrodriving)} = 2 - 1/\eta < 0.5 \text{ self-locking}]$$

- You must clean the output shafts and flange surfaces thoroughly to ensure they are free of anti-corrosion agents, contamination or similar. Use a commercially available solvent. Do not let the solvent come into contact with the sealing lips of the oil seals – danger of damage to the material!
- When the drive is installed in abrasive ambient conditions, protect the output end oil seals against wear.

4.3 Installing the gear unit

The gear unit or gearmotor is only allowed to be installed in the specified mounting position.

The support structure must have the following characteristics:

- Level
- Vibration damping
- Torsionally rigid

Maximum permitted flatness error for foot and flange mounting (approximate values with

reference to DIN ISO 1101):

- Gear unit size ≤ 68 : max. 0.4 mm
- Gear unit size 78 ... 108: max. 0.5 mm
- Gear unit size 138 ... 148: max. 0.7 mm
- Gear unit size 158 ... 188: max. 0.8 mm

that you comply with the permitted overhung and axial loads!

Secure the gearmotors with bolts of quality 8.8.

Secure the following gearmotors with bolts of quality 10.9:

- TRF38, TR38F with flange Φ 120 mm
- TRF48, TR48F with flange Φ 140 mm
- TRF58, TR58F with flange Φ 160 mm

Do not tighten the housing legs and mounting flanges against one another and ensure



The oil checking and drain screws and the breather valves must be freely accessible!

At the same time, also check that the oil fill is as specified for the mounting position (see Sec. "Lubricants" / "Lubricant fill quantities" or refer to the information on the name-plate).

The gear units are filled with the required oil volume at the factory. There may be slight deviations at the oil level plug as a result of the mounting position, which are permitted within the manufacturing tolerances.

Adjust the lubricant fill volumes and the position of the breather valve accordingly in the event of a change of mounting position.

Please contact Transcyko customer service if you change the mounting position of TK gear units to M5 or M6 or between M5 and M6.

Please contact our customer service if you change the mounting position of size TS48-TS98, TS gear units to mounting position M2.

Installation in damp locations or in the open

Drives are supplied in corrosion-resistant versions for use in damp areas or in the open air. Repair any damage to the paint work (e.g. on the breather valve).

When mounting the motors onto AM adapters, seal the flange areas with a suitable sealing compound.

Gear unit venting

No breather plug is required for the following gear units:

- TR18, TR28 and TF28 in mounting positions M1, M3, M5 and M6

TONGYU supplies all other gear units with the breather valve installed and activated according to the particular mounting position.

Mechanical Installation

Installing the gear unit

Activating the breather valve

As a rule, the breather valve is already activated at the factory. If the breather valve has not been activated, you must remove the transport fixture from the breather valve before starting up the gear unit!

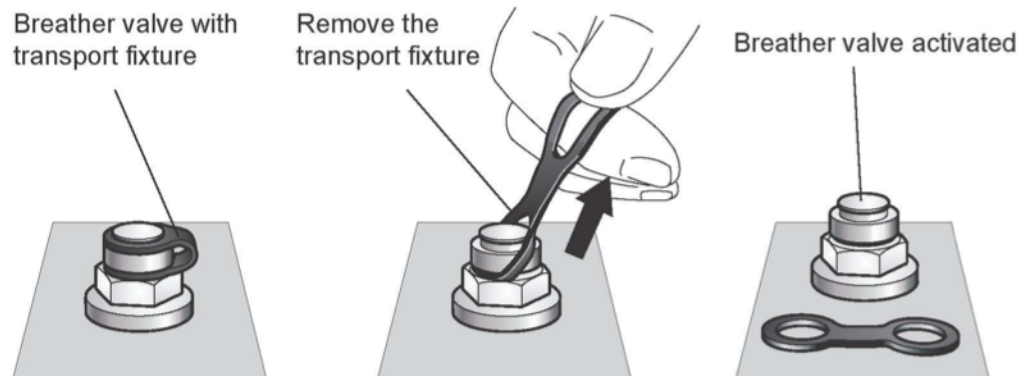

Painting the gear unit

If you paint or respray the drive, ensure that you cover the breather valve and oil seals carefully. Remove the strips of tape after completing the painting work.

4.4 Gear unit with solid shaft

Installing input and output elements

The following figure shows a mounting device for installing couplings or hubs on gear unit or motor shaft ends. It may be possible to dispense with the thrust bearing on the mounting device.

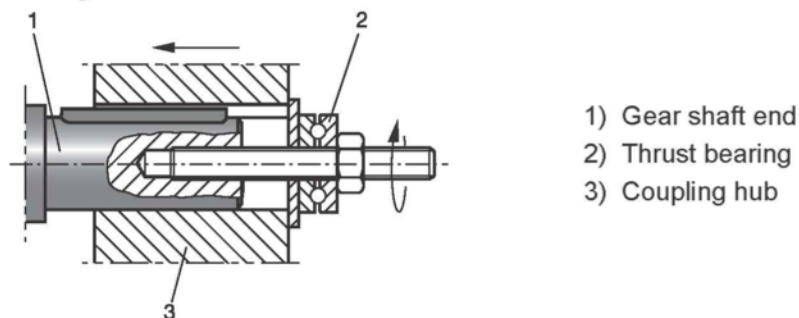

Avoid impermissibly high overhung loads: Install the gear or chain sprocket according to figure B.

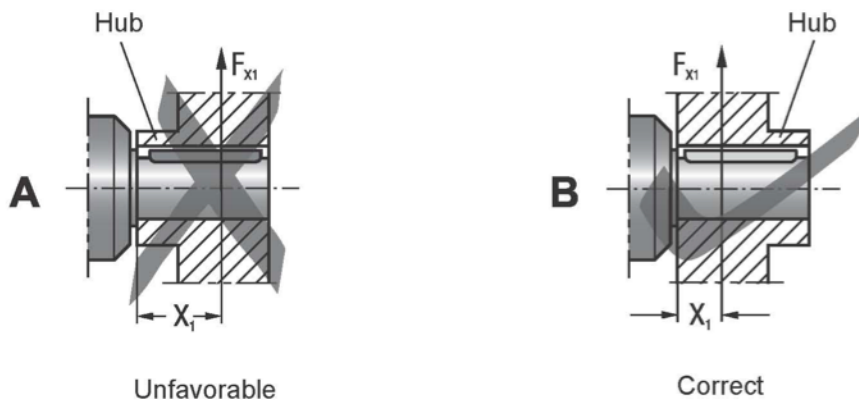



- Only use a mounting device for installing input and output elements. Use the center bore and the thread on the shaft end for positioning.
- **Never drive belt pulleys, couplings, pinions, etc. onto the shaft end by hitting them with a hammer. This will damage the bearings, housing and the shaft!**
- In the case of belt pulleys, make sure the belt is tensioned correctly in accordance with the manufacturer's instructions.
- Power transmission elements should be balanced after fitting and must not give rise to any impermissible radial or axial forces (see the "Gearmotor" catalogs for permitted values).



Installing couplings

Note:

Assembly is easier if you first apply lubricant to the output element or heat it up briefly (to 80 ... 100 °C).

Couplings must be mounted and balanced according to the information provided by the coupling manufacturer:

- a) Maximum and minimum clearance
- b) Axial misalignment
- c) Angular misalignment

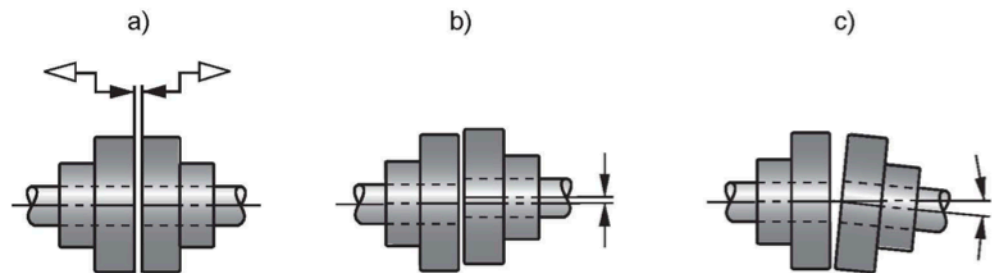

Figure 6: Clearance and misalignment for coupling installation



Input and output elements such as belt pulleys, couplings, etc. must be protected against contact!

4.5 Torque arms for mounted gear units

Do not place torque arms under strain during installation

Parallel shaft helical gear units

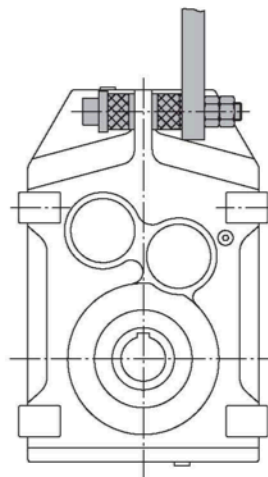

Figure 7: Torque arm for parallel shaft helical gear units

Mechanical Installation

Torque arms for mounted gear units

Helical-bevel gear units

- Bush with bearings on both ends → (1)
- Install connection end B as a mirror image of A.

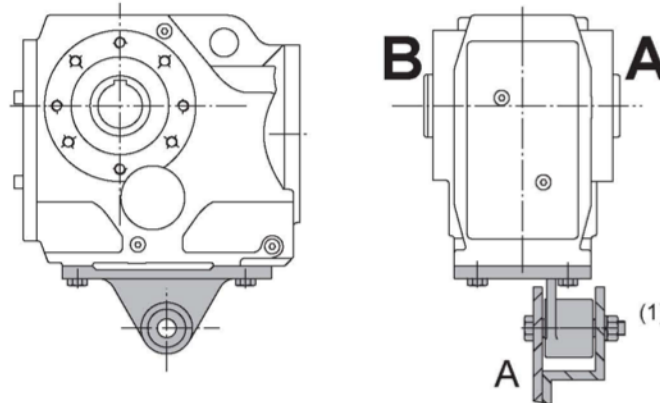

Figure 8: Torque arm for helical-bevel gear units

Gear unit	Bol ts	Tightening torque
TKA38	M10 × 25 - 8.8	48 Nm
TKA48	M10 × 30 - 8.8	48 Nm
TKA68	M12 × 35 - 8.8	86 Nm
TKA78	M16 × 40 - 8.8	210 Nm
TKA88	M16 × 45 - 8.8	210 Nm
TKA98	M20 × 50 - 8.8	410 Nm
TKA108	M24 × 60 - 8.8	710 Nm
TKA128	M36 × 130 - 8.8	2500 Nm
TKA158	M36 × 130 - 8.8	2500 Nm

Helical-worm gear units

- Bush with bearings on both ends → (1)

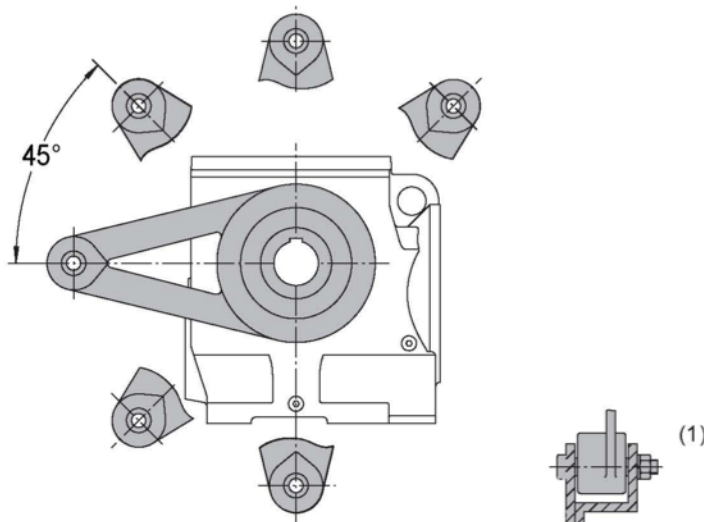

Figure 9: Torque arm for helical-worm gear units

Gear unit	Bol ts	Tightening torque
TSA38	M6 × 16 - 8.8	11 Nm
TSA48	M8 × 20 - 8.8	25 Nm
TSA58	M8 × 20 - 8.8	25 Nm
TSA68	M12 × 25 - 8.8	86 Nm
TSA78	M12 × 35 - 8.8	86 Nm
TSA88	M16 × 35 - 8.8	210 Nm
TSA98	M16 × 35 - 8.8	210 Nm

4.6 Mounted gear unit with keyway or splined hollow shaft



For the configuration of customer shafts, please also refer to the design notes in the Gearmotors catalog!

Installation notes

1. Apply lubricate oil

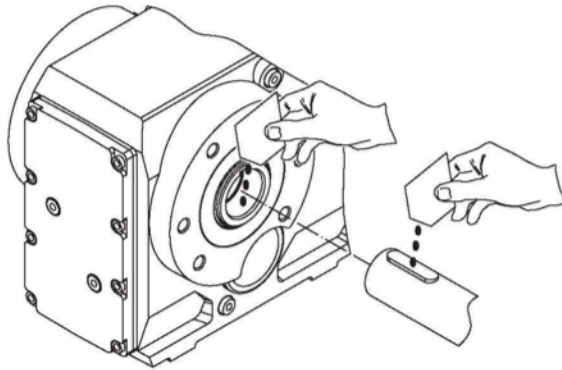

2. Distribute the lubricate oil carefully

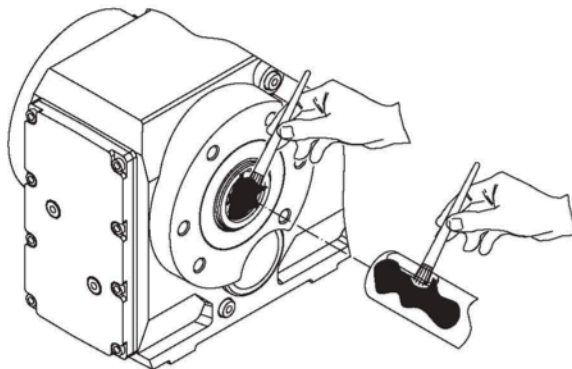

3. Install the shaft and secure it axially
(mounting is facilitated by using a mounting device)

3A: Mounting with standard scope of delivery

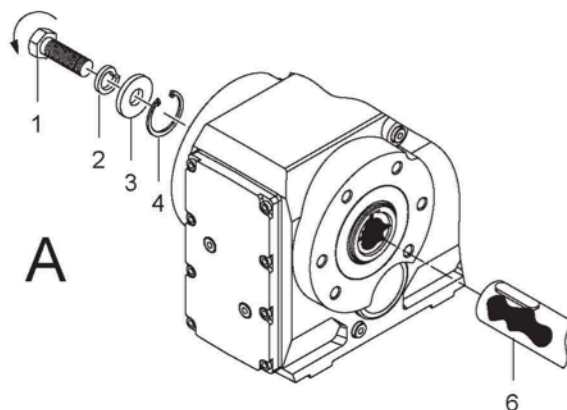

- 1 Short retaining bolt
(standard scope of delivery)
- 2 Lock washer
- 3 Washer
- 4 Circlip
- 6 Customer shaft

Mechanical Installation

Mounted gear unit with keyway or splined hollow shaft

3B: Assembly and Disassembly with Transcyko Kits

- Customer's shaft with contact shoulder

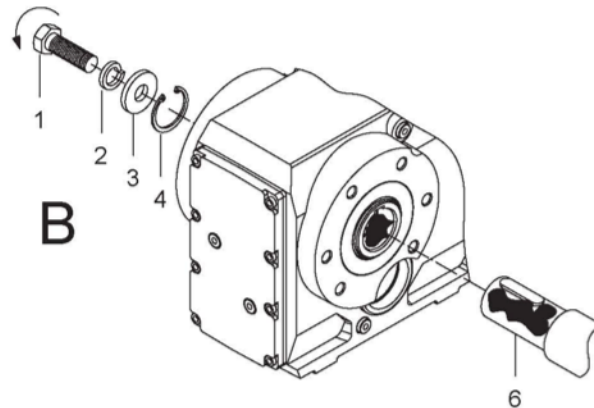

- 1 Retaining bolt
- 2 Lock washer
- 3 Washer
- 4 Circlip
- 6 Customer's shaft with contact shoulder

3C: Assembly and Disassembly with Transcyko Kits

- Customer's shaft without contact shoulder

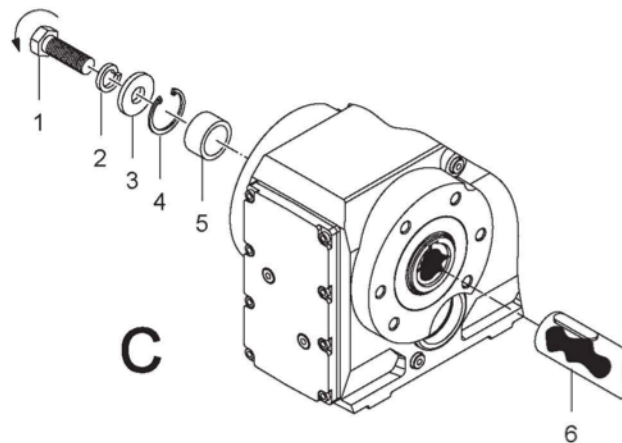

- 1 Retaining bolt
- 2 Lock washer
- 3 Washer
- 4 Circlip
- 5 Spacer
- 6 Customer's shaft without contact shoulder

4. Tighten the retaining bolt to the appropriate torque (see table).

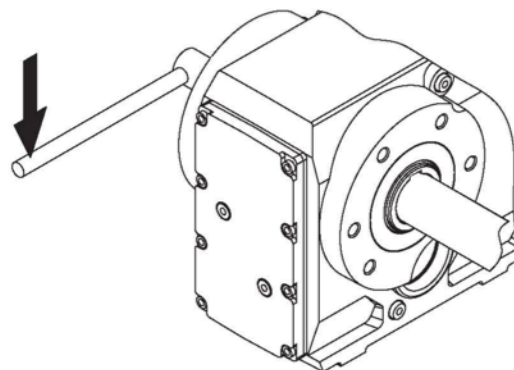

Bolt	Tightening torque [Nm]
M5	5
M6	8
M10/12	20
M16	40
M20	80
M24	200



Note:

We suggest to machining the diameter ϕd of the user shaft between two bearing surface smaller.

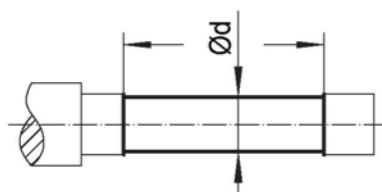

Removal notes

This description is only applicable when the gear unit was assembled using the installation / removal kit from **Transcyko** (see the previous description, point 3B or 3C).

1. Loosen the retaining bolt 1.
2. Remove parts 2 to 4 and, if fitted, spacer 5.

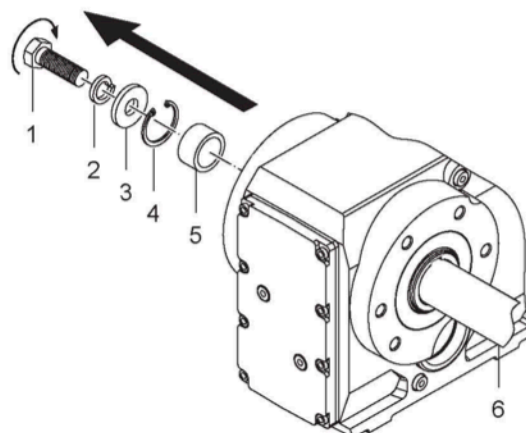

- 1 Retaining bolt
- 2 Lock washer
- 3 Washer
- 4 Circlip
- 5 Spacer
- 6 Customer shaft

3. Insert the forcing washer 8 and the fixed nut 7 from **Transcyko** installation / removal kit between the customer's shaft 6 and the circlip 4.
4. Re-insert the circlip 4.
5. Screw the retaining bolt [1] back in. Now you can force the gear unit off the shaft by tightening the bolt.

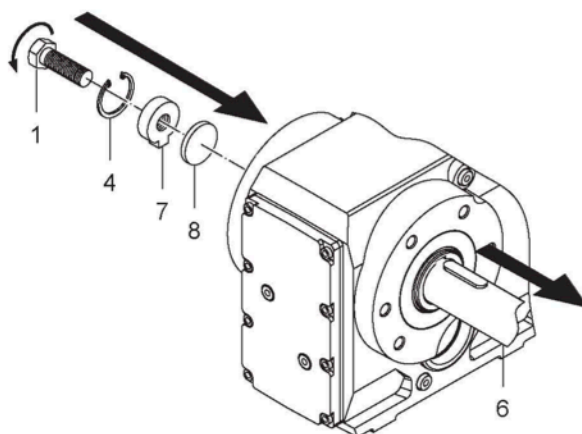

- 1 Retaining bolt
- 4 Circlip
- 6 Customer shaft
- 7 Fixed nut
- 8 Forcing washer

Mechanical Installation

Mounted gear unit with keyway or splined hollow shaft

Installation / removal kit

Transcyko installation/removal kit can be ordered under the following part number.

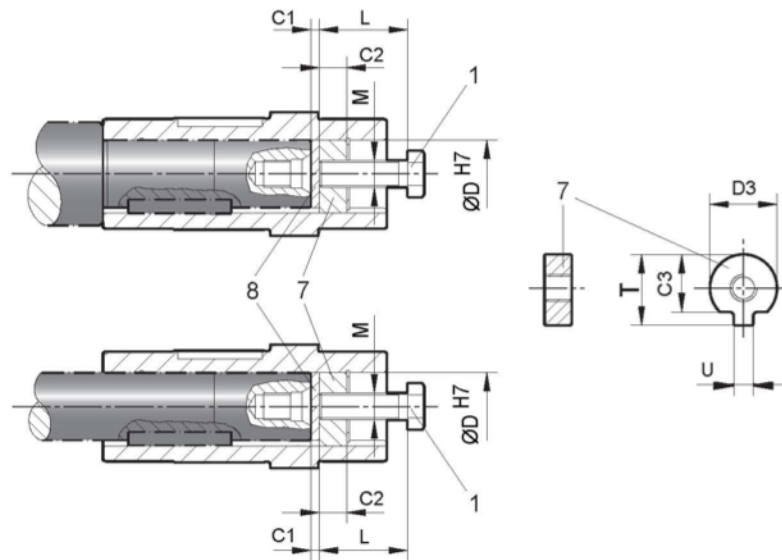

Figure 10: Installation/removal kit

- 1 Retaining bolt
- 7 Fixed nut for disassembly
- 8 Forcing washer

Type	D ^{H7} [mm]	M ¹⁾	C1 [mm]	C2 [mm]	C3 [mm]	U ^{-0.5} [mm]	T ^{-0.5} [mm]	D3 ^{-0.5} [mm]	L [mm]
TFA..28, TSA..48	25	M10	5	10	20	7.5	28	24.7	35
TFA..38, TKA..38, TSA..48, TSA..58	30	M10	5	10	25	7.5	33	29.7	35
TFA..48, TKA..48, TSA..58	35	M12	5	12	29	9.5	38	34.7	45
TFA..58, TKA..58, TFA..68, TKA..68, TSA..68	40	M16	5	12	34	11.5	41.9	39.7	50
TSA..68	45	M16	5	12	38.5	13.5	48.5	44.7	50
TFA..78, TKA..78, TSA..78	50	M16	5	12	43.5	13.5	53.5	49.7	50
TFA..88, TKA..88, TSA..78, TSA..88	60	M20	5	16	56	17.5	64	59.7	60
TFA..98, TKA..98, TSA..88, TSA..98	70	M20	5	16	65.5	19.5	74.5	69.7	60
TFA..108, TKA..108, TSA..98	90	M24	5	20	80	24.5	95	89.7	70
TFA..128, TKA..128	100	M24	5	20	89	27.5	106	99.7	70
TFA..158, TKA..158	120	M24	5	20	107	31	127	119.7	70

1) Retaining bolt

The assembly kit for mounting the customer shaft is a recommendation from **Transcyko**. Always check whether this design can compensate the axial loads. In particular applications (e.g. mounting mixer shafts), a different design may have to be used to secure the shaft axially. In these cases, customers can use their own devices. However, you must ensure that these designs do not cause potential sources of combustion according to DIN EN 13463 (for example, impact sparks).

4.7 Mounted gear units with shrink disc

Installation notes



- Do not tighten the locking bolts unless the shaft is installed - the hollow shaft could become deformed!
- Apply the grease on the out surface of the sleeve on the locking area to avoid cauterization.

1. Loosen the locking bolts by a few turns (do not unscrew them completely!).

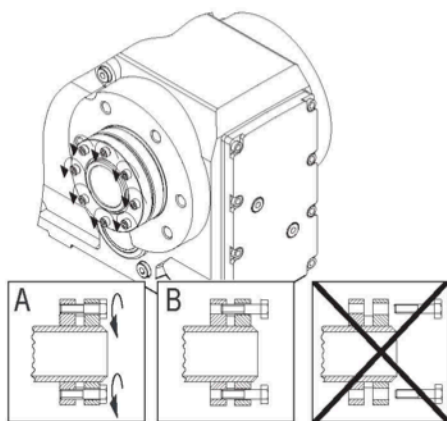

2. Carefully degrease the hollow shaft hole and the input shaft.

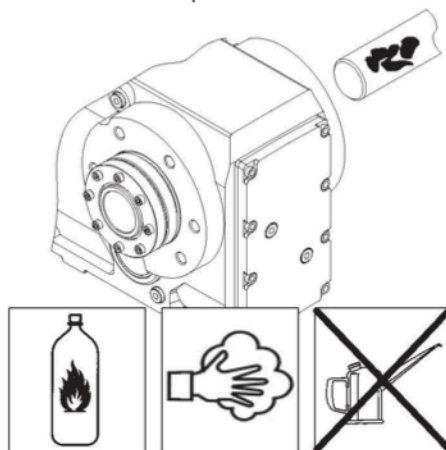

3. Hollow shaft/input shaft after degreasing.

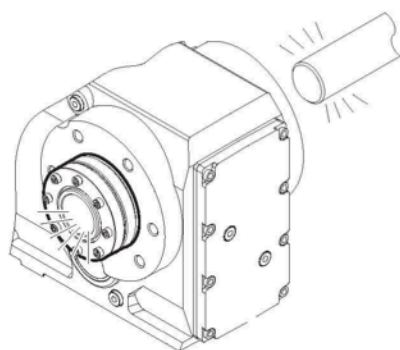

4. Apply lubricate oil to the input shaft¹⁾ in the area of the bushing.

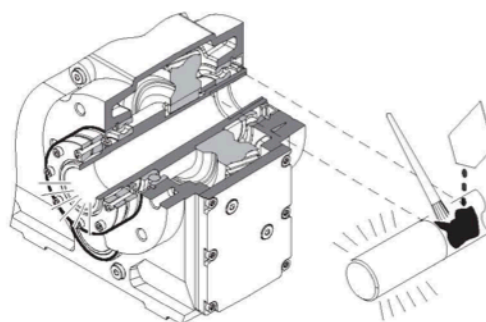

1) It is essential to make sure that the clamping area of the shrink disc is free from grease!

For this reason, never apply lubricate oil directly to the bushing as the paste may be able to get into the clamping area of the shrink disc when the input shaft is put on.

5. Install the input shaft, making sure that the locking collars of the shrink disc are installed in parallel to each other²⁾. For gear unit housing with a shaft collar, mount the shrink disc to the stop on the shaft collar. For gear unit housing without a shaft collar, mount the shrink disc with a clearance of 1 to 2 mm from the gear unit housing. Tighten the locking bolts with the torque wrench by working round several times from one bolt to the next (not in diametrically opposite sequence) until the bolts cannot be tightened any more. See the following table for tightening torques.



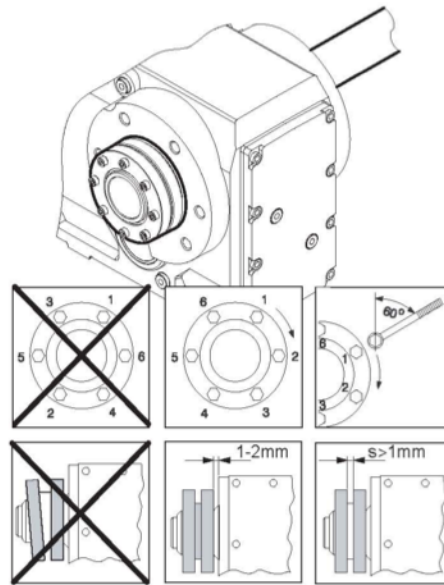

- 2) After installation
- There must be a gap $s > 1$ mm between the locking collars
 - Grease the outside of the hollow shaft in the area of the shrink disc to prevent corrosion.

Gear unit type			Bolt	Nm	\leftarrow Max ¹⁾
		TSH38	M5	5	60°
TKH38~78	TFH38~78	TSH48~78	M6	12	
TKH88/98	TFH88/98	TSH88/98	M8	30	
TKH108	TFH108		M10	59	
TKH128/158	TFH128		M12	100	
TKH168			M16	250	
TKH188			M20	470	

1) Maximum tightening angle per cycle

Notes on removing the shrink disc

1. Unscrew the locking bolts evenly one after the other. Each locking bolt may only be unscrewed by about one quarter turn in the initial cycle. This is in order to avoid tilting and jamming the locking collars. Do not fully unscrew the locking bolts!
2. Remove the shaft or pull the hub off the shaft. (You must first remove any rust that may have formed between the hub and the end of the shaft.)
3. Pull the shrink disc off the hub.



Cleaning and lubricating the shrink disc

Caution!

Risk of injury if the shrink disc is not removed correctly!

There is no need to strip down and re-grease disassembled shrink disks before they are screwed back on.

The shrink disc only needs to be cleaned and re-greased if it is contaminated.

Use one of the following solid lubricants for the tapered surfaces.

Apply more lubrication on the fastening bolt.

4.8 AM adapter coupling

IEC adapter AM63 -225

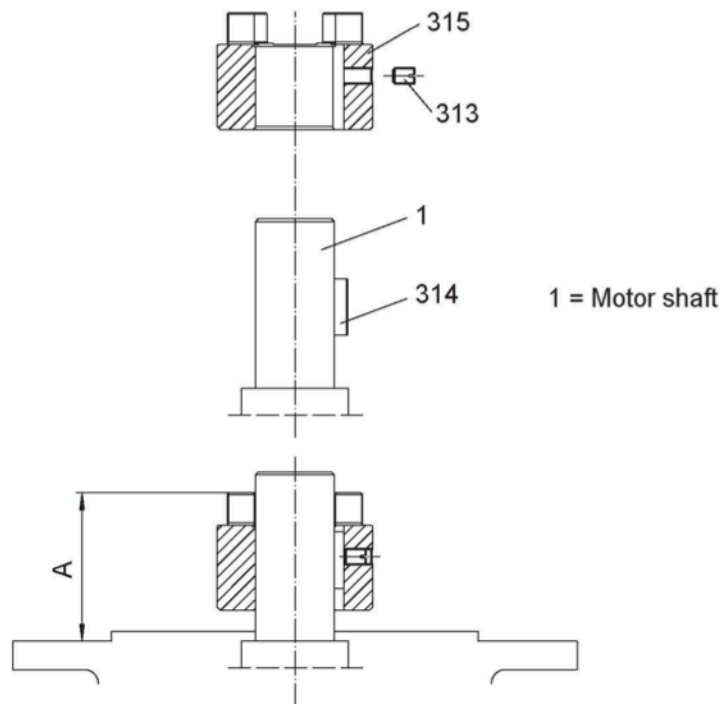

1. Clean the motor shaft and flange surfaces of the motor and adapter.
2. Remove the key from the motor shaft and replace it with the supplied key (314) (not AM63 and AM250).
3. Heat the coupling half (315) to approx. 80 – 100 °C, push the coupling half onto the motor shaft. Until stop at motor shaft shoulder (position to point A except for AM25 / AM280).
4. Secure key and coupling half using grub screw (313) and tightening torque TA on motor shaft according to the table.
5. Check point A.
6. Seal the contact surfaces between the adapter and motor using a suitable sealing compound.
7. Mount the motor on the adapter. When doing this, make sure the coupling dogs of the adapter shaft engage in the plastic spider.

IEC AM	63 / 71	80 / 90	100 / 112	132	160 / 180	200	225	250 / 280
A	25	31.5	41.5	54	76.5	78.5	93.5	139
TA	1.5	1.5	4.8	4.8	10	17	17	17
Thread	M4	M4	M6	M6	M8	M10	M10	M10



To avoid contact corrosion, we recommend applying lubricate oil to the motor shaft before mounting the coupling half.



When installing a motor onto the adapter, you must use an anaerobic fluid seal to ensure that moisture cannot penetrate the adapter.

Permitted loads



The load data specified in the following table must not be exceeded when a motor is mounted

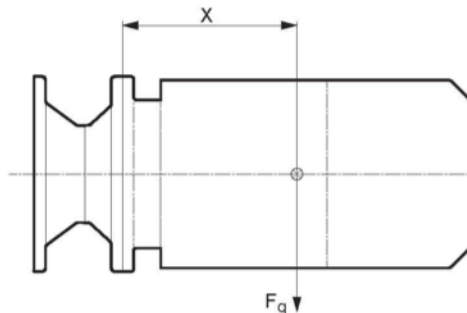

IEC adapter type	x ¹⁾ [mm]	IEC adapter	IEC adapter type	x ¹⁾ [mm]	IEC adapter
AM63/71	77	530	AM132..	186	4700
AM80/90	113	420	AM160/180	251	4600
AM100/112	144	2000	AM200/225	297	5600
AM1322)	186	1600	AM250/280	390	11200

- 1) The maximum permitted weight of the attached motor F_{qmax} must be reduced proportionally as the distance between the adapter flange and the middle of the motor (x) increases. When this distance is reduced, the maximum permitted weight F_{qmax} cannot be increased.
- 2) Diameter of the adapter drive flange: 160 mm.

Adapter AM with backstop AM

Check the direction of rotation of the drive before installation and startup. Please inform **Transcyko** customer service if the direction of rotation is incorrect.

The backstop is maintenance-free in operation, and does not require any further maintenance work.

The backstops have a minimum lift-off speed depending on the size (→ following table). If the minimum lift-off speeds are violated, the backstops are subject to wear, and the resulting friction causes the temperature to increase.

Type	Maximum locking torque of backstop [Nm]	Minimum lift-off speed [1/min]
AM80/90	90	640
AM100/112	340	600
AM132	700	550
AM160/180	1200	630
AM200/225	1450	430



In rated operation, the lift-off speeds must not drop below the minimum values. The lift-off speeds are only permitted to drop below the minimum values during startup or braking.

4.9 AD input shaft assembly

Type with centering shoulder AD../ZR

Mounting applications on the input shaft assembly with centering shoulder.

1. Retaining bolts of a suitable length must be used to secure the application. The length l of the new bolts is calculated as follows:

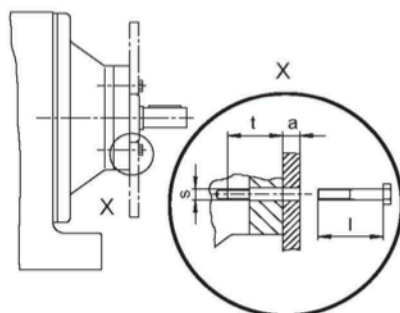

$$l = t + a$$

t = Screw-in depth (see table)

a = Thickness of the application

s = Retaining thread (see table)

Round down the calculated bolt length to the next smaller standard length.

2. Remove the retaining bolts from the centering shoulder.
3. Clean the contact surface and the centering shoulder.
4. Clean the threads of the new bolts and apply a bolt locking compound to the first few threads.
5. Position the application against the centering shoulder and tighten the retaining bolts to the specified tightening torque TA (see table).

Type	Screw-in depth t [mm]	Retaining thread s	Tightening torque TA for connection bolts in strength class 8.8 [Nm]
AD2/ZR	25.5	M8	25
AD3/ZR	31.5	M10	48
AD4/ZR	36	M12	86
AD5/ZR	44	M12	86
AD6/ZR	48.5	M16	210
AD7/ZR	49	M20	410
AD8/ZR	42	M12	86

Permitted loads



The load values specified in the following table must not be exceeded.

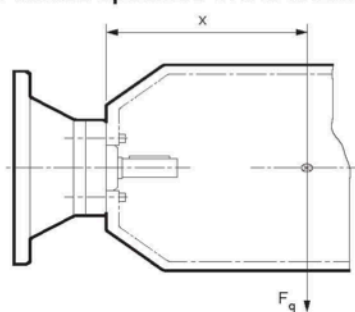

Type	$x^{1)}$ [mm]	$F_q^{1)}$ [N]
AD2/ZR	193	330
AD3/ZR	274	1400
AD4/ZR ²⁾	361	1120
AD4/ZR		3300
AD5/ZR	487	3200
AD6/ZR	567	3900
AD7/ZR	663	10000
AD8/ZR	516	4300

1) Maximum load values for connection bolts in strength class 8.8. The maximum permitted weight of the attached motor F_{qmax} must be reduced proportionally as the distance between the adapter flange and the middle of the motor (x) increases. When this distance is reduced, the F_{qmax} cannot be increased.

2) Diameter of the adapter output flange: 160 mm

5. Startup



Prior to startup check that the oil level is as specified for the mounting position. The oil checking and drain screws and the breather valves must be freely accessible.

5.1 Startup of helical-worm gear units



Attention: For TS..8 series helical-worm geared motor, change the output shaft direction of rotation from clockwise to counter clockwise. Only request you change the two feeder line of the motor.

Run-in period

helical-worm gear units require a run-in period of at least 24 hours before reaching their maximum efficiency. A separate run-in period applies for each direction of rotation if the gear unit is operated in both directions of rotation. The table shows the average power reduction during the run-in period.

No. of starts	Power reduction	i range	No. of starts	Power reduction	i range
1 start	ca.12%	ca.50~280	5 start	ca.3%	ca.6~25
2 start	ca.6%	ca.20~75	6 start	ca.2%	ca.7~25
3 start	ca.3%	ca.20~90			

5.2 Startup of helical, parallel shaft helical and helical-bevel gear units

No special startup instructions are required for helical, parallel shaft helical and helical-bevel gear units providing the gear units have been installed in accordance with Sec. "Mechanical Installation".

6. Inspection and Maintenance

6.1 Inspection and maintenance intervals

Frequency	What to do?
<ul style="list-style-type: none"> Every 3000 machine hours, at least every 6 months. 	<ul style="list-style-type: none"> Check oil and oil level. Check the seals visually for leakage. For gear units with a torque arm: Check the rubber buffer and change it, if necessary
<ul style="list-style-type: none"> Depending on the operating conditions (see chart below), every 3 years at the latest. According to oil temperature. 	<ul style="list-style-type: none"> Change mineral oil. Replace anti-friction bearing grease (recommendation). Replace oil seal (do not install it in the same track).
<ul style="list-style-type: none"> Depending on the operating conditions (see chart below), every 5 years at the latest. According to oil temperature. 	<ul style="list-style-type: none"> Change synthetic oil Replace anti-friction bearing grease (recommendation). Replace oil seal (do not install it in the same track).
<ul style="list-style-type: none"> Gear units TR18, TR28, TF28 are have lubrication for life and are therefore maintenance-free 	
<ul style="list-style-type: none"> Varying (depending on external factors). 	<ul style="list-style-type: none"> Touch up or renew the surface/anticorrosion coating.

6.2 Lubricant change intervals

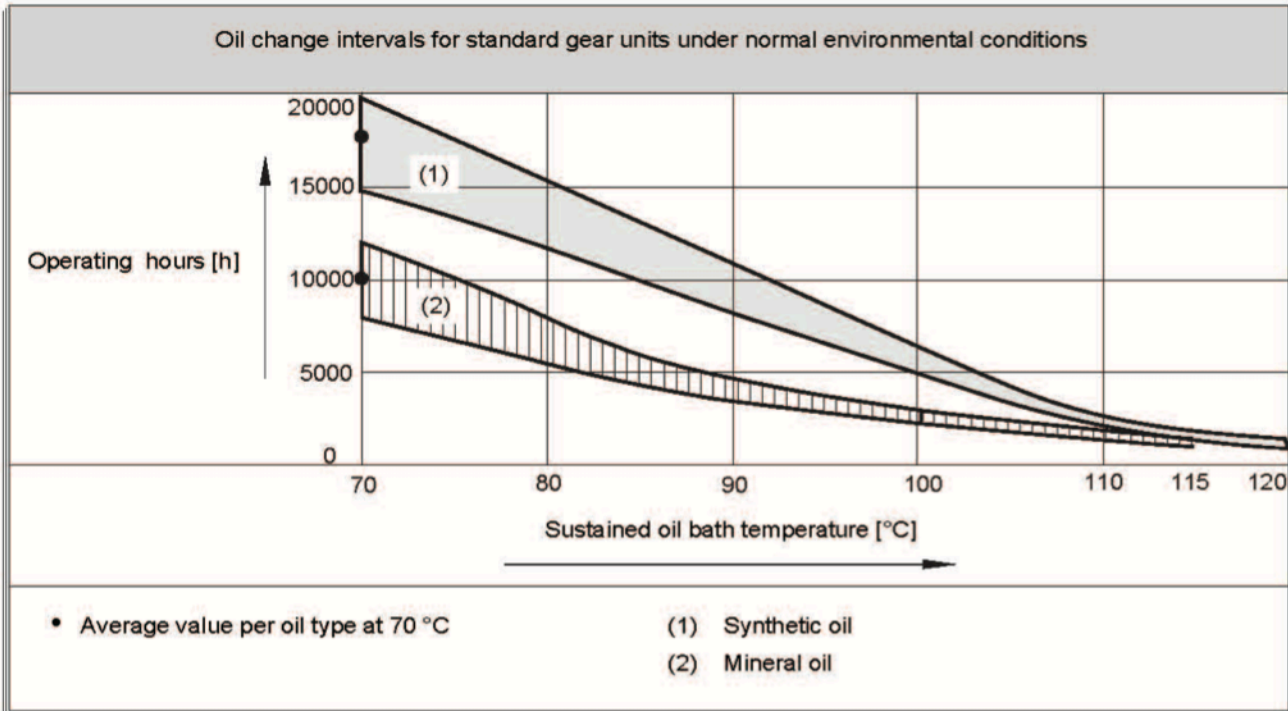

Figure 11: Oil change intervals for standard gear units under normal environmental conditions

6.3 Inspection and maintenance of the gear unit

Do not intermix synthetic lubricants and do not mix synthetic and mineral lubricants together!

The standard lubricant is mineral oil .

The position of the oil level and oil drain plug and the breather valve depends on the mounting position. Refer to the diagrams of the mounting positions.

Checking the oil level



1. De-energize the gearmotor and secure it to prevent it from being switched on inadvertently!

Wait until the gear unit has cooled off – Danger of burns!

2. Refer to Sec. "Installing the gear unit" when changing the mounting position!

3. For gear units with an oil level plug: Remove the oil level plug, check the fill level and correct it if necessary. Screw the oil level plug back in.

Checking the oil consistency



1. De-energize the gearmotor and secure it to prevent it from being switched on inadvertently!

Wait until the gear unit has cooled off – Danger of burns!

2. Remove a little oil from the oil drain plug.

3. Check the oil consistency.

- Viscosity

- If you can see that the oil is heavily contaminated, we recommend that you change the oil even if this is outside the service intervals specified in "Inspection and maintenance periods".

4. For gear units with an oil level plug: Remove the oil level plug, check the fill level and correct it if necessary. Screw the oil level plug back in.

Changing the oil



Only change the oil when the gear unit is at operating temperature.

De-energize the gearmotor and secure it to prevent it from being switched back on inadvertently!

Wait until the gear unit cools down - Danger of burns!

Note: The gear unit must still be warm otherwise the high viscosity of excessively cold oil will make it harder to drain the oil correctly.

With oil drain plug / oil level screw

1. Place a container underneath the oil drain plug.
2. Remove the oil level plug, breather plug/breather valve and oil drain plug.
3. Drain all the oil.
4. Screw in the oil drain plug.
5. Pour in new oil of the same type through the vent hole (if changing the oil type, please first contact our customer service). Do not mix synthetic lubricants.
 - Pour in the volume of oil in accordance with the mounting position (see Sec. "Lubricant fill quantities") or as specified on the nameplate.
 - Check at the oil level plug.
6. Screw the oil level plug back in.
7. Screw in the breather plug/breather valve.

Without oil drain plug / oil level plug

1. Remove cover plate.
2. Drain the oil through the cover plate opening.
3. Pour in new oil of the same type through the vent hole (if changing the oil type, please first contact our customer service). Do not mix synthetic lubricants.
 - Pour in the volume of oil in accordance with the mounting position (see Sec. "Lubricant fill quantities") or as specified on the nameplate.
4. Check the oil level (→ Sec. "Check oil level for gear units with oil level plug")
5. Attach cover plate (observe the tightening torque and series → Sec. "Check the oil level for gear units without an oil level plug")

Changing the oil seal

1. **De-energize the gearmotor and secure it to prevent it from being switched on inadvertently!**
Wait until the gear unit has cooled off – Danger of burns!
2. When changing the oil seal, ensure that there is a sufficient grease reservoir between the dust lip and protective lip, depending on the type of gear unit.
3. If you use double oil seals, the space has to be filled one-third with grease.

6.4 Inspection / maintenance of AM adapters

Frequency	What to do?
<ul style="list-style-type: none"> • Every 3000 machine hours, at least every 6 months 	<ul style="list-style-type: none"> • Check torsional play • Visually check the elastic annular gear • Check the adapter visually for leakage
<ul style="list-style-type: none"> • After 25000 - 30000 machine hours 	<ul style="list-style-type: none"> • Renew the anti-friction bearing grease • Replace oil seal (do not install it in the same track) • Change the elastic annular gear.

6.5 Inspection / maintenance of AD adapters

Frequency	What to do?
<ul style="list-style-type: none"> • Every 3000 machine hours, at least every 6 months 	<ul style="list-style-type: none"> • Check running noise for possible bearing damage • Check the adapter visually for leakage
<ul style="list-style-type: none"> • After 25000 - 30000 machine hours 	<ul style="list-style-type: none"> • Renew the anti-friction bearing grease • Change the oil seal

7. Malfuncions

Customer service

Please have the following information to hand if you require the assistance of our customer service:
Data from the nameplate (complete)
Nature and extent of the fault
Time and peripheral circumstances of the fault
Presumed cause

7.1 Gear unit malfuncions

Problem	Possible cause	Remedy
Unusual, regular running noise	A. Meshing/grinding noise: Bearing damage. B. Knocking noise: Irregularity in the gearing	A. Check the oil, change bearings B. Contact customer service
Unusual, irregular running noise	Foreign bodies in the oil	<ul style="list-style-type: none"> • Check the oil • Stop the drive service
Oil leaking ¹⁾ <ul style="list-style-type: none"> • From the gear cover plate • From the motor flange • From the motor oil seal • From the gear unit flange • From the output end oil seal 	A. Rubber seal on the gear cover plate leaking B. Seal defective C. Gear unit not vented	A. Tighten the bolts on the gear cover plate and observe the gear unit. Oil still leaking: Contact customer service B. Contact customer service C. Vent the gear unit (see "Mounting Positions")
Oil leaking from breaking valve	A. Too much oil B. Drive operated in incorrect mounting position C. Frequent cold starts(oil foams) and / or high oillevel	A. Correct the oil level (see Sec.Inspection and Maintenance") B. Mount the breather valve correctly (see Sec."Mounting Positions")and correct the oil level(see"Lubricants") "
Output shaft does not turn although the motor is running or the input shaft is rotated	Connection between shaft and hub in gear unit interrupted	Send in the gear unit/gearmotor for repair

1) Short-term oil/grease leakage at the oil seal is possible in the run-in phase (24 hours running time).

7.2 AM adapter malfuncions

Problem	Possible cause	Remedy
Unusual, regular running noise	Meshing/grinding noise: Bearing damage	Contact our company customer service
Oil leaking	Seal defective	Contact our company customer service
Output shaft does not turn although the motor is running or the input shaft is rotated	Connection between shaft and hub in gear unit interrupted	Send the gear unit to our company for repair.
Change in running noise and / or vibrations occur	A. Annular gear wear, short-term torque transfer through metal contact B. Bolts to secure hub axially are loose.	A. Change the annular gear B. Tighten the bolts
Premature wear in annular gear	A. Contact with aggressive fluids / oil; ozone influence; too high ambient temperatures etc, which can cause a change in the physical properties of the annular gear. B. Impermissibly high ambient/contact temperature for the annular gear; maximum permitted temperature –20 °C to +80 °C. C. Overload	Contact our company customer service

7.3 AD input shaft assembly malfuncions

Problem	Possible cause	Remedy
Unusual, regular running noise	Meshing/grinding noise: Bearing damage.	Contact our company customer service
Oil leaking	Seal defective	Contact our company customer service
Output shaft does not turn although the input shaft is rotated.	Connection between shaft and hub in gear unit or cover interrupted	Send the gear unit to our company for repair.

Mounting Positions

General information on mounting positions

8 Mounting Positions

8.1 General information on mounting positions

Mounting position designation

Differentiates between six mounting positions M1 ... M6 for gear units. The following figure shows the spatial orientation of the gearmotor in mounting positions M1 ... M6.

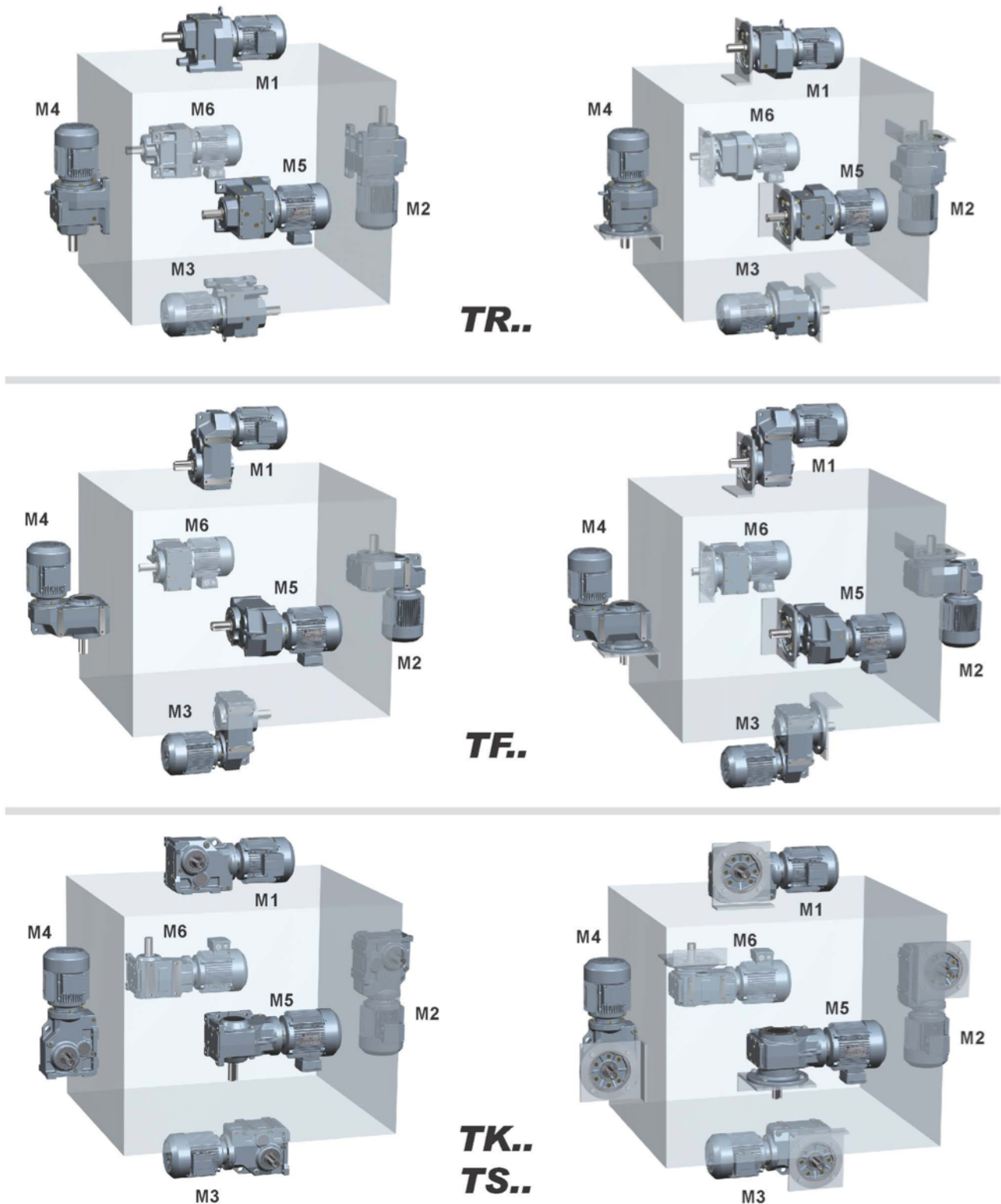





Figure 12: Depiction of mounting positions M1 ... M6

Operating Instructions – Gear Unit, TR.., TF.., TK.., TS..

8.2 Mounting positions of TRX helical gearmotors

TRX58 - TRX108

Symbol	Meaning
	Breather valve
	Oil level plug
	Oil drain plug

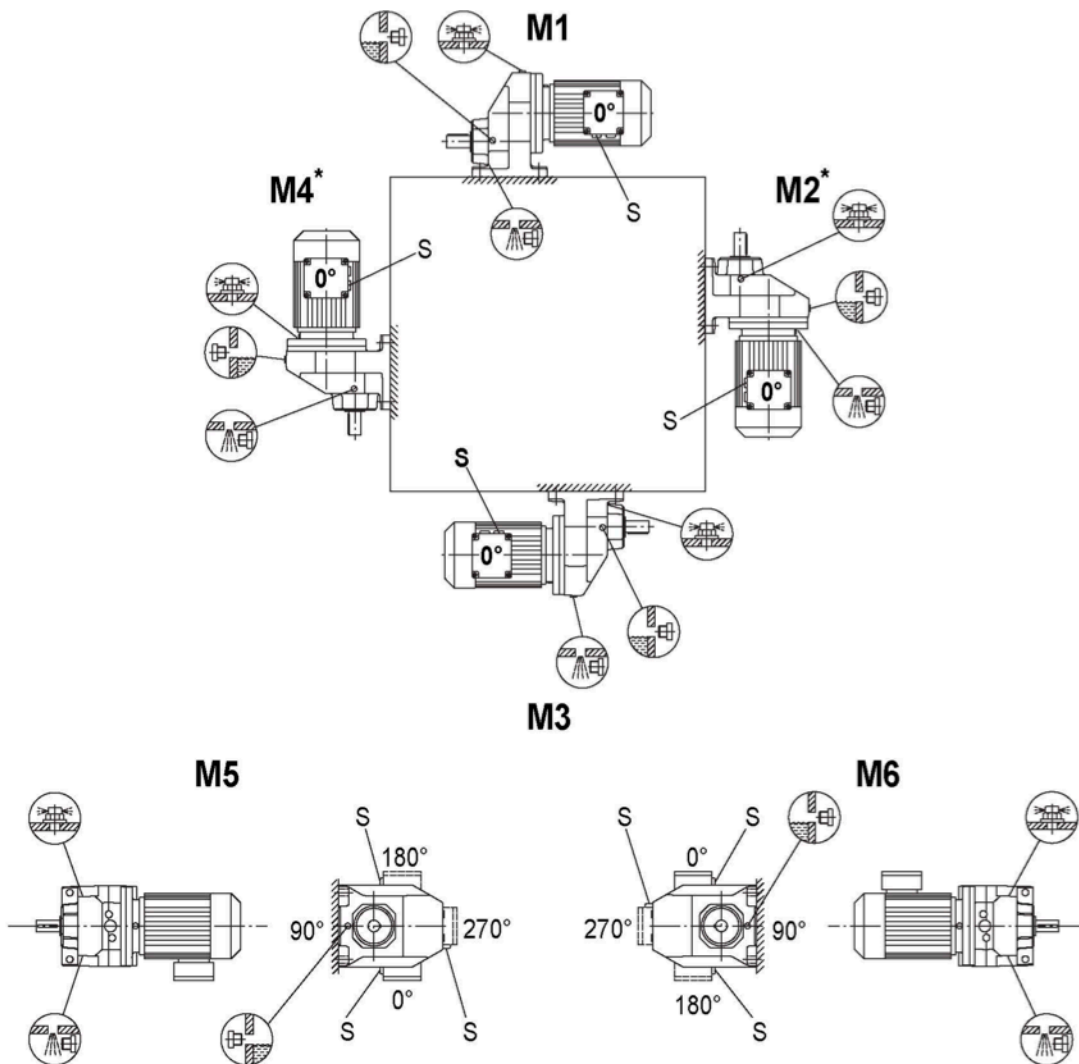
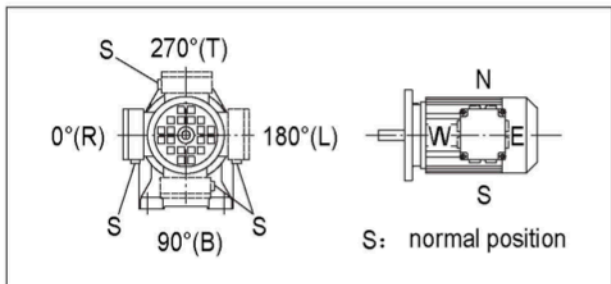



Important: Please refer to the  information in the 'Geared Motors' catalog, Sec(page 47).

Mounting Positions

Mounting positions of TRX helical gearmotors

TRXF58 - TRXF108

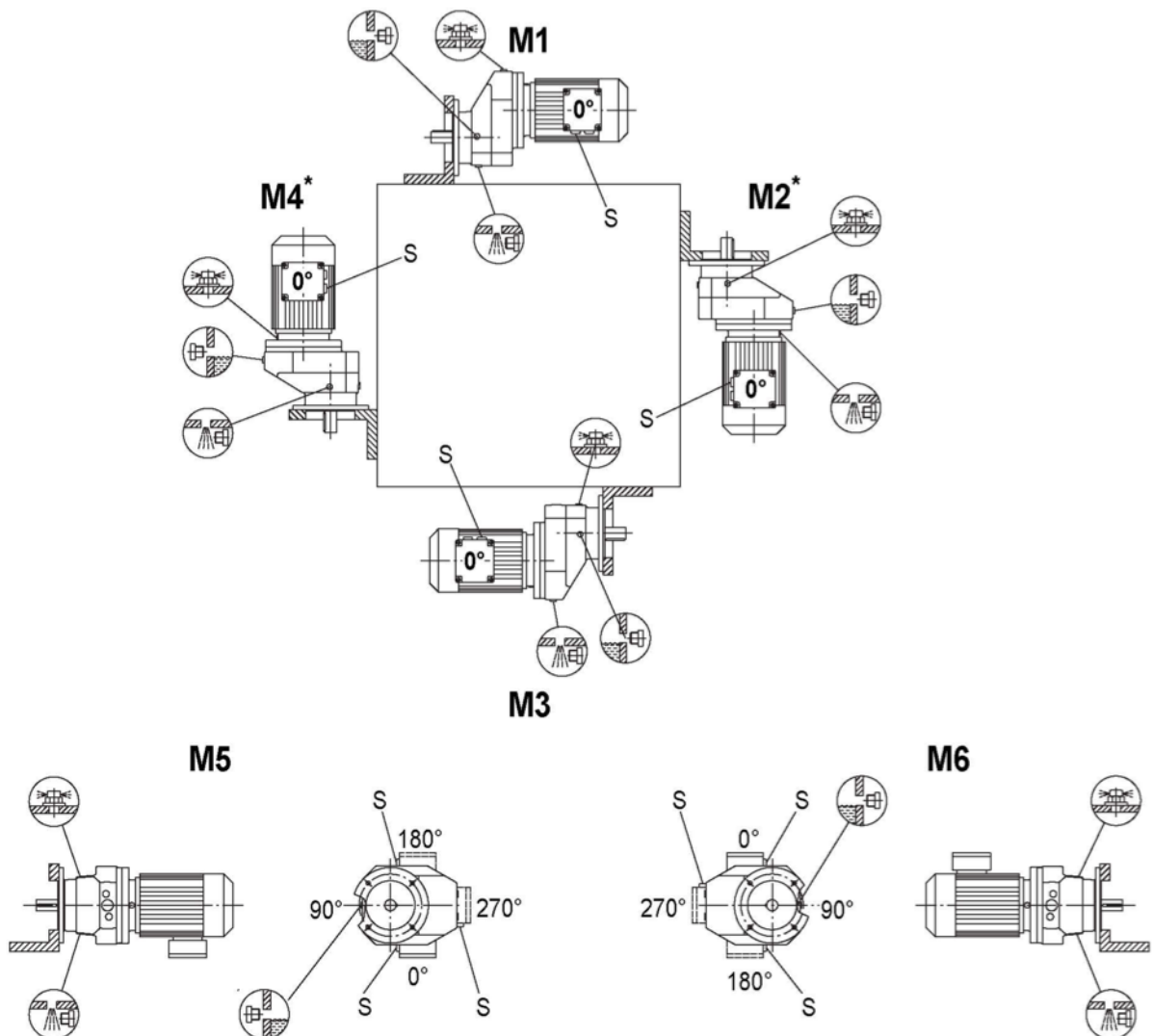
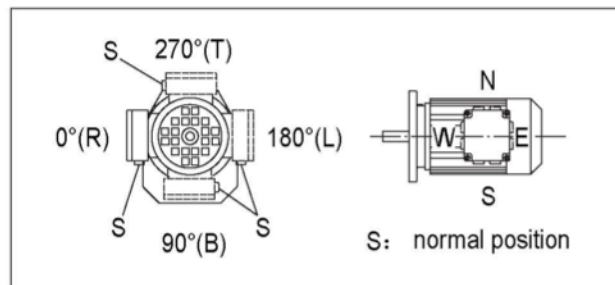

Symbol	Meaning
	Breather valve
	Oil level plug
	Oil drain plug



Important: Please refer to the  information in the 'Geared Motors' catalog, Sec(page 47).



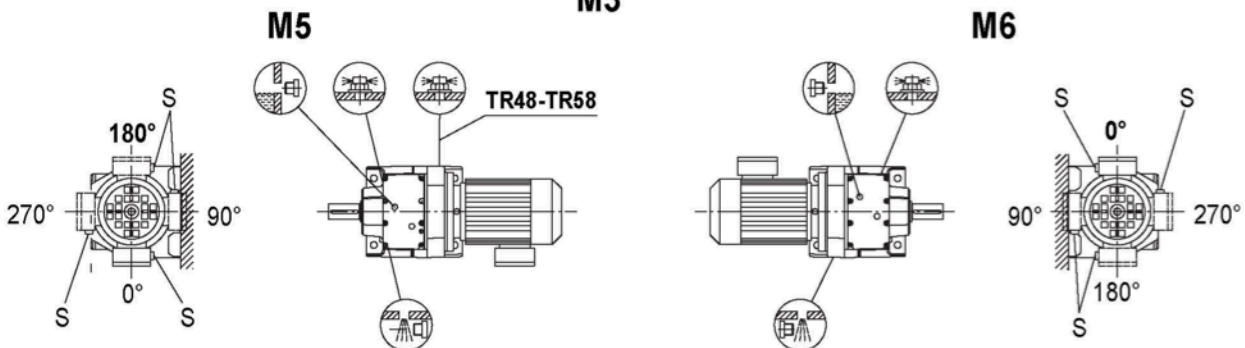
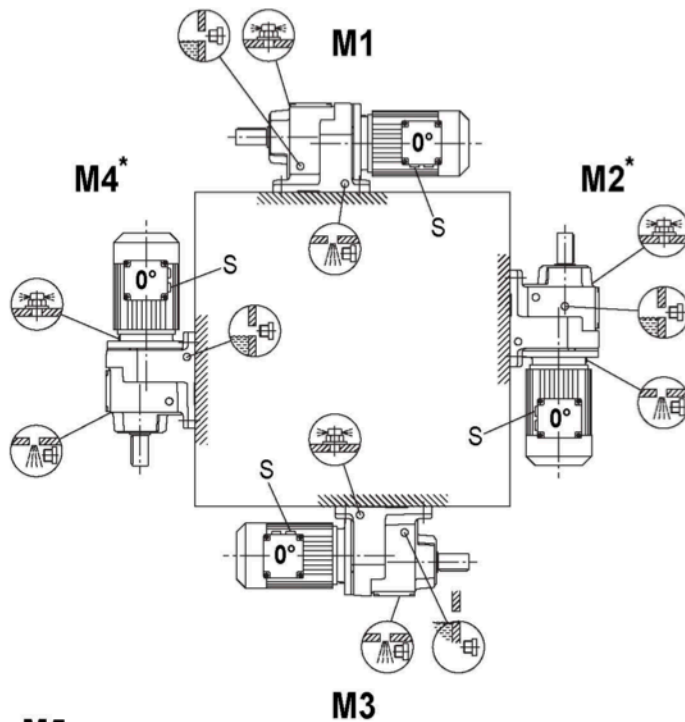
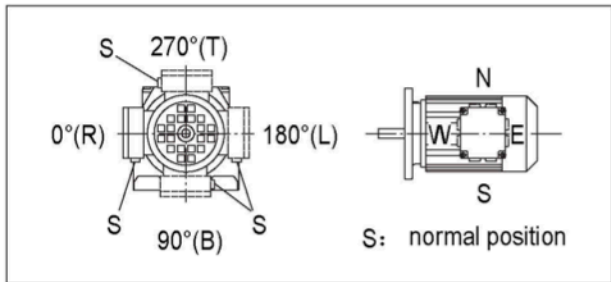

8.3 Mounting positions for TR helical gearmotors

TR28 - TR168

Symbol	Meaning
	Breather valve
	Oil level plug
	Oil drain plug



Mounting position	Gear unit size	Input speed [1/min]
M2*, M4*	98...108	>2500
	>108	>1500



TR28		M1, M3, M5, M6
TR28	 	
TR48, TR58		M5

Important: Please refer to the  information in the 'Geared Motors' catalog, Sec.(page 47).

Mounting Positions



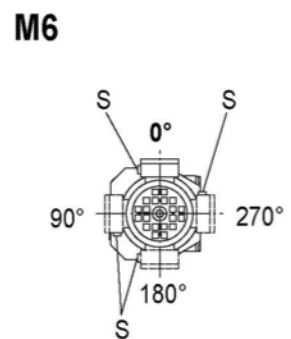
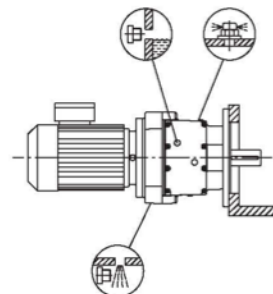
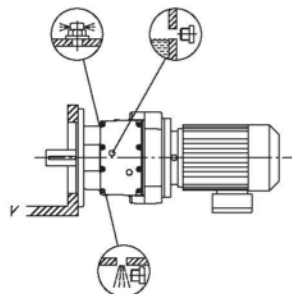
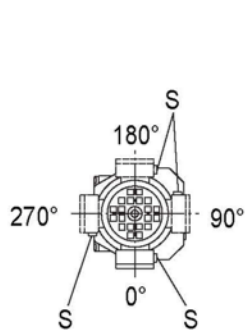
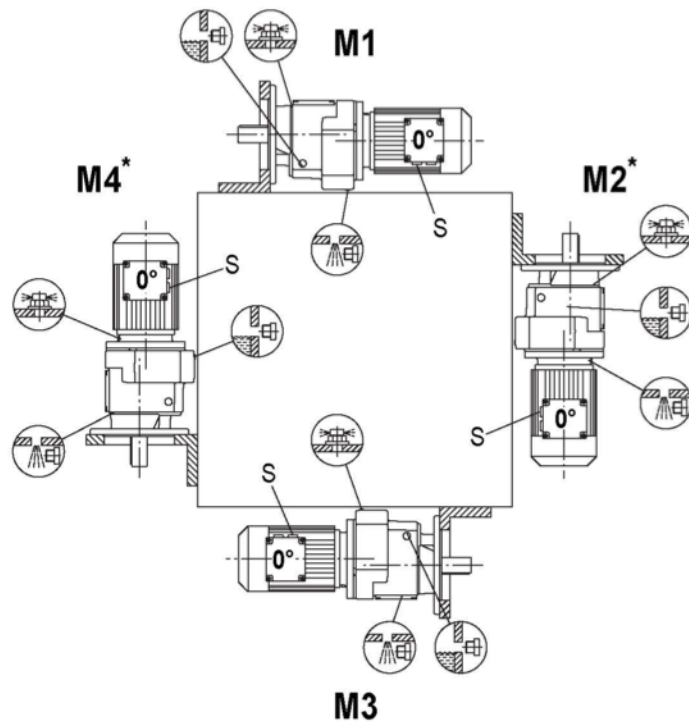
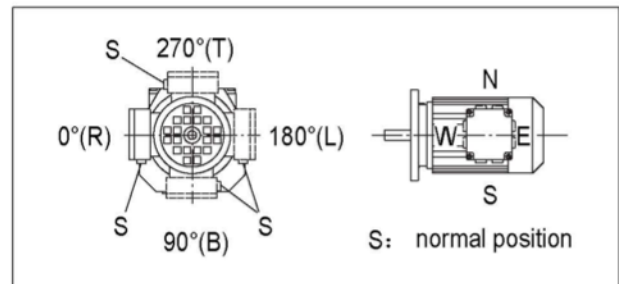

Mounting positions for TR helical gearmotors

TRF28 - TRF168



Symbol	Meaning
	Breather valve
	Oil level plug
	Oil drain plug



Mounting position	Gear unit size	Input speed [1/min]
M2*, M4*	98...108	>2500
	>108	>1500

TRF28		M1, M3, M5, M6
TRF28	 	
TRF48, TRF58		M5

TR28F - TR88F

Symbol	Meaning
	Breather valve
	Oil level plug
	Oil drain plug

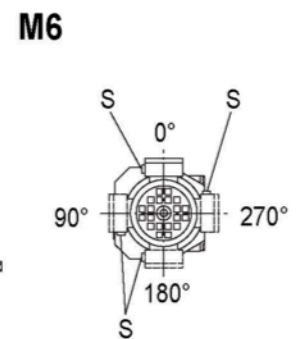
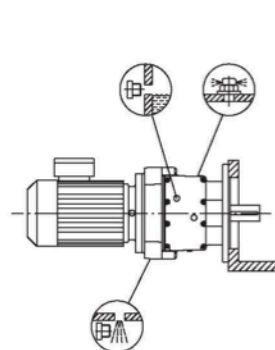
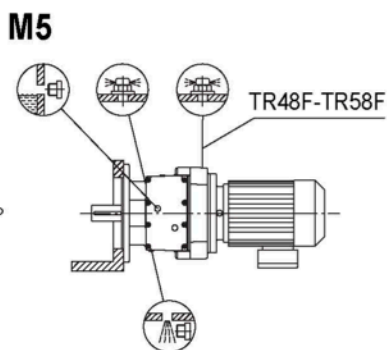
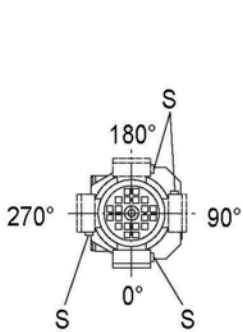
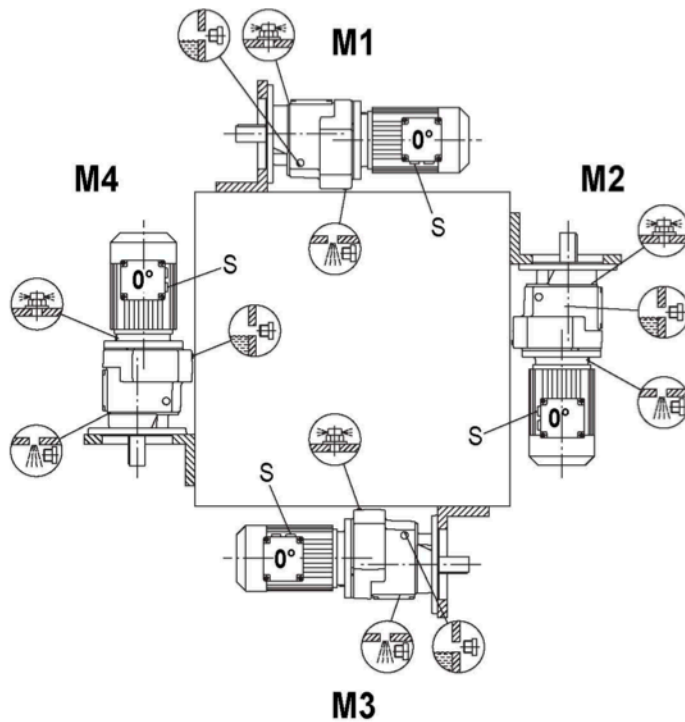
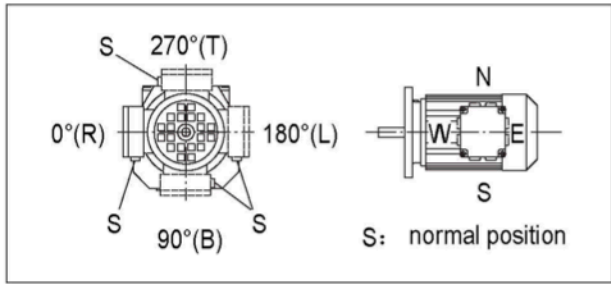

TR28F  **M1, M3, M5, M6**

TR28F  

TR48F, TR58F  **M5**

Mounting Positions

Mounting positions for parallel shaft helical gearmotors

8.4. Mounting positions for parallel shaft helical gearmotors

TFITFA..B/TFH28B-158B,TFV28B-108B

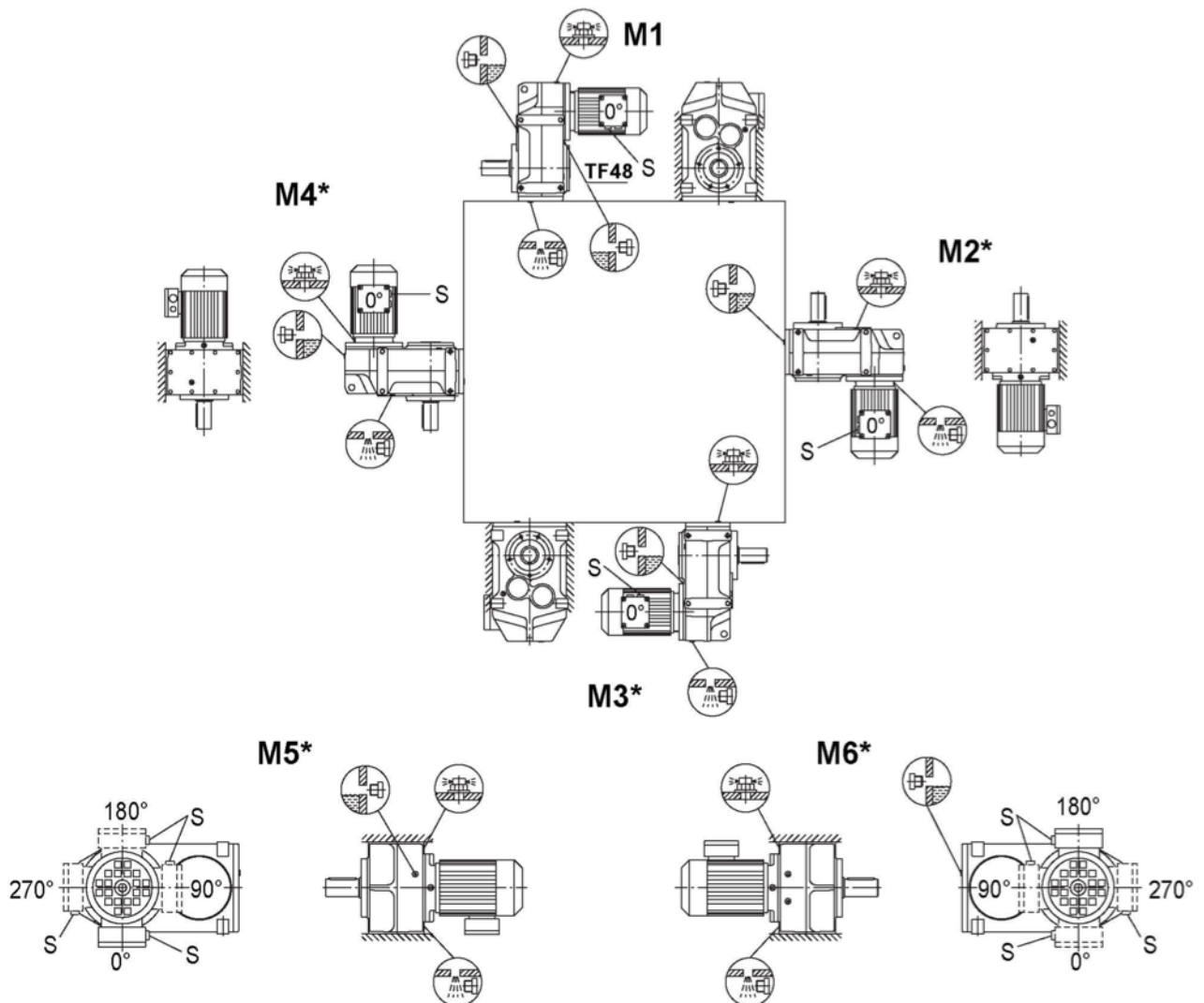
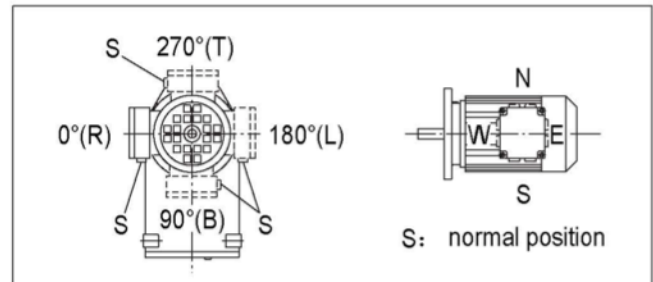

Symbol	Meaning
	Breather valve
	Oil level plug
	Oil drain plug



Mounting position	Gear unit size	Input speed [r/min]
M2*, M3*, M4*, M5*, M6*	98...108	>2500
	>108	>1500



TF28		M1, M3, M5, M6
TF28		M1-M6
TF28		M1, M3, M5, M6

TFF/TFAF/TFHF/TFAZ/TFHZ28-158,TFVF/TFVZ28-108

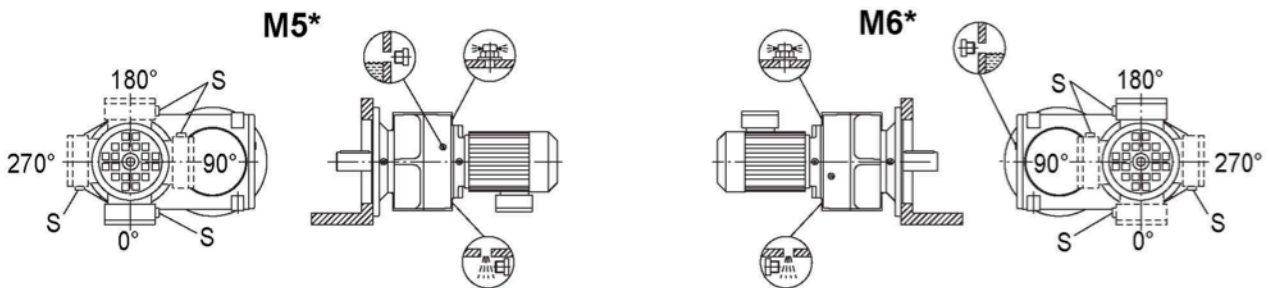
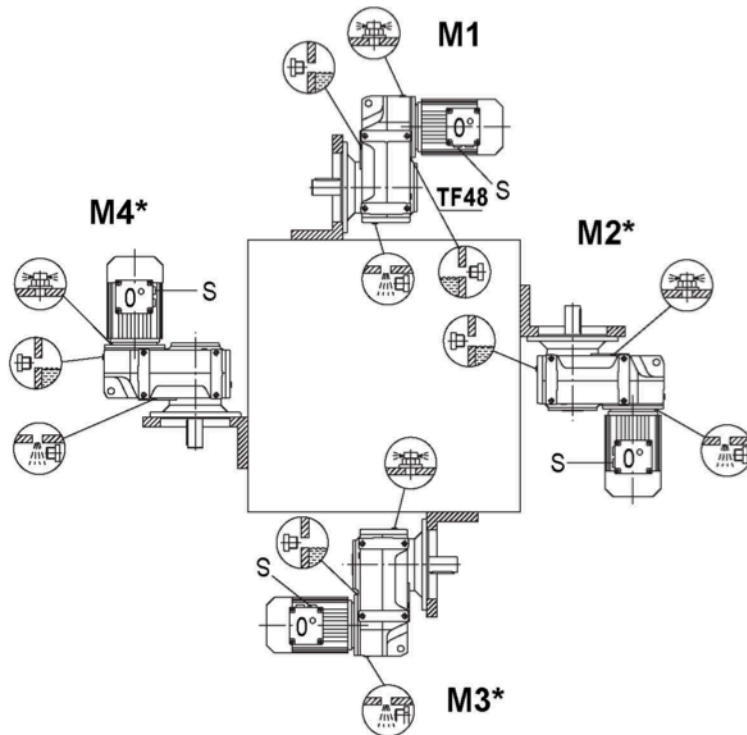
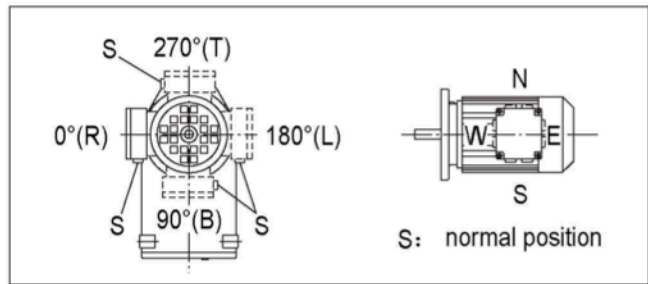
Symbol	Meaning
	Breather valve
	Oil level plug
	Oil drain plug





Mounting position	Gear unit size	Input speed [r/min]
M2*,M3*,M4*,M5*,M6*	98...108	>2500
	>108	>1500

- TF28**  **M1, M3, M5, M6**
- TF28**  **M1-M6**
- TF28**  **M1, M3, M5, M6**



Mounting Positions
Mounting positions for parallel shaft helical gearmotors

TFAITFH28-158,TFV28-108

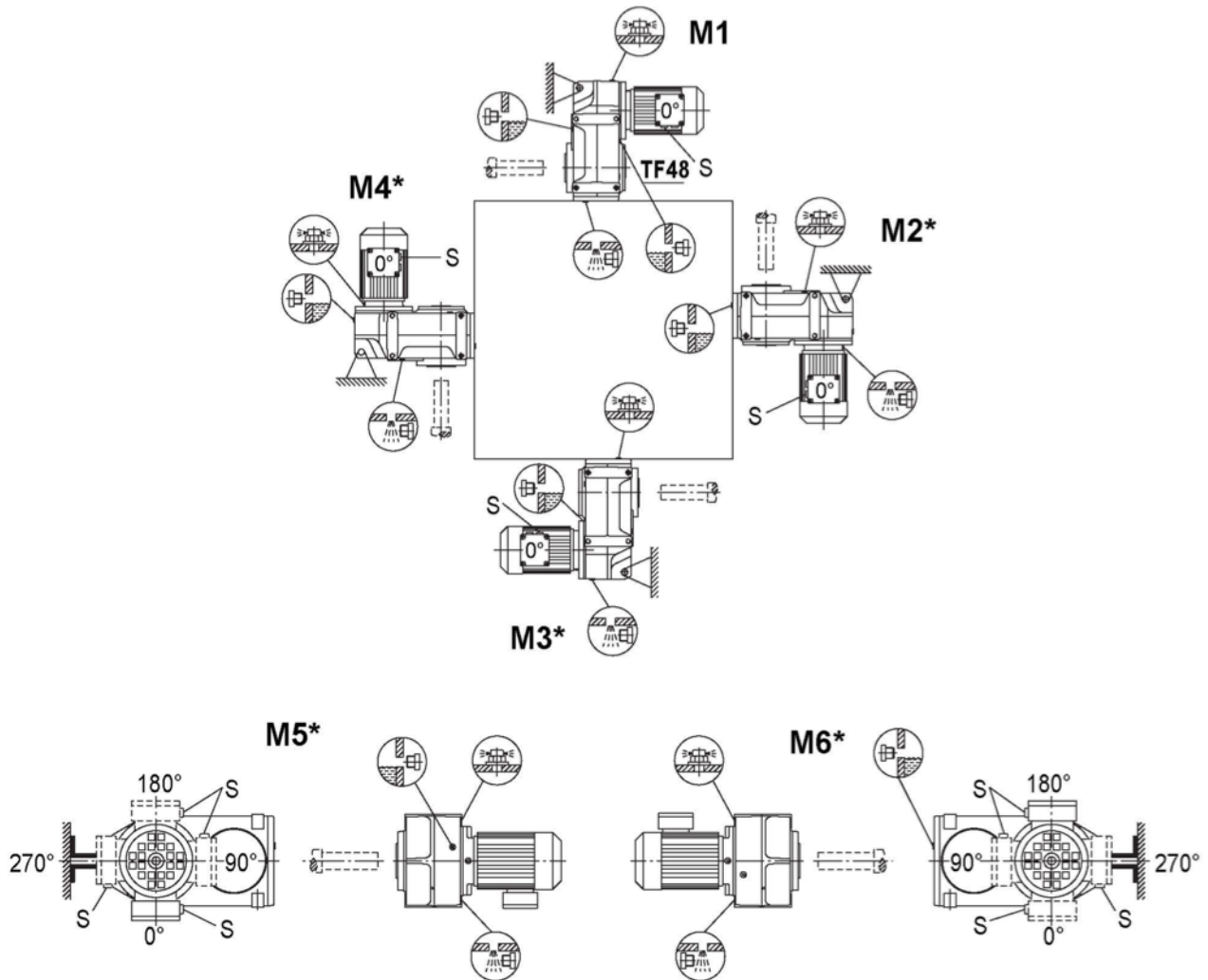
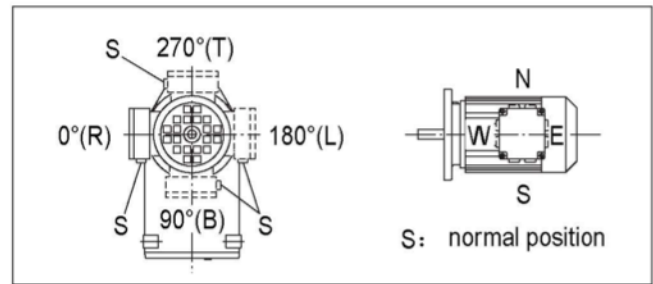
Symbol	Meaning
	Breather valve
	Oil level plug
	Oil drain plug



Mounting position	Gear unit size	Input speed [r/min]
M2*,M3*,M4*,M5*,M6*	98...108	>2500
	>108	>1500

TF28		M1, M3, M5, M6
TF28		M1-M6
TF28		M1, M3, M5, M6

8.5. Mounting positions for helical-bevel gearmotors

TK/TKA..B/TKH38B-158B,TKV38B-108B

Symbol	Meaning
	Breather valve
	Oil level plug
	Oil drain plug

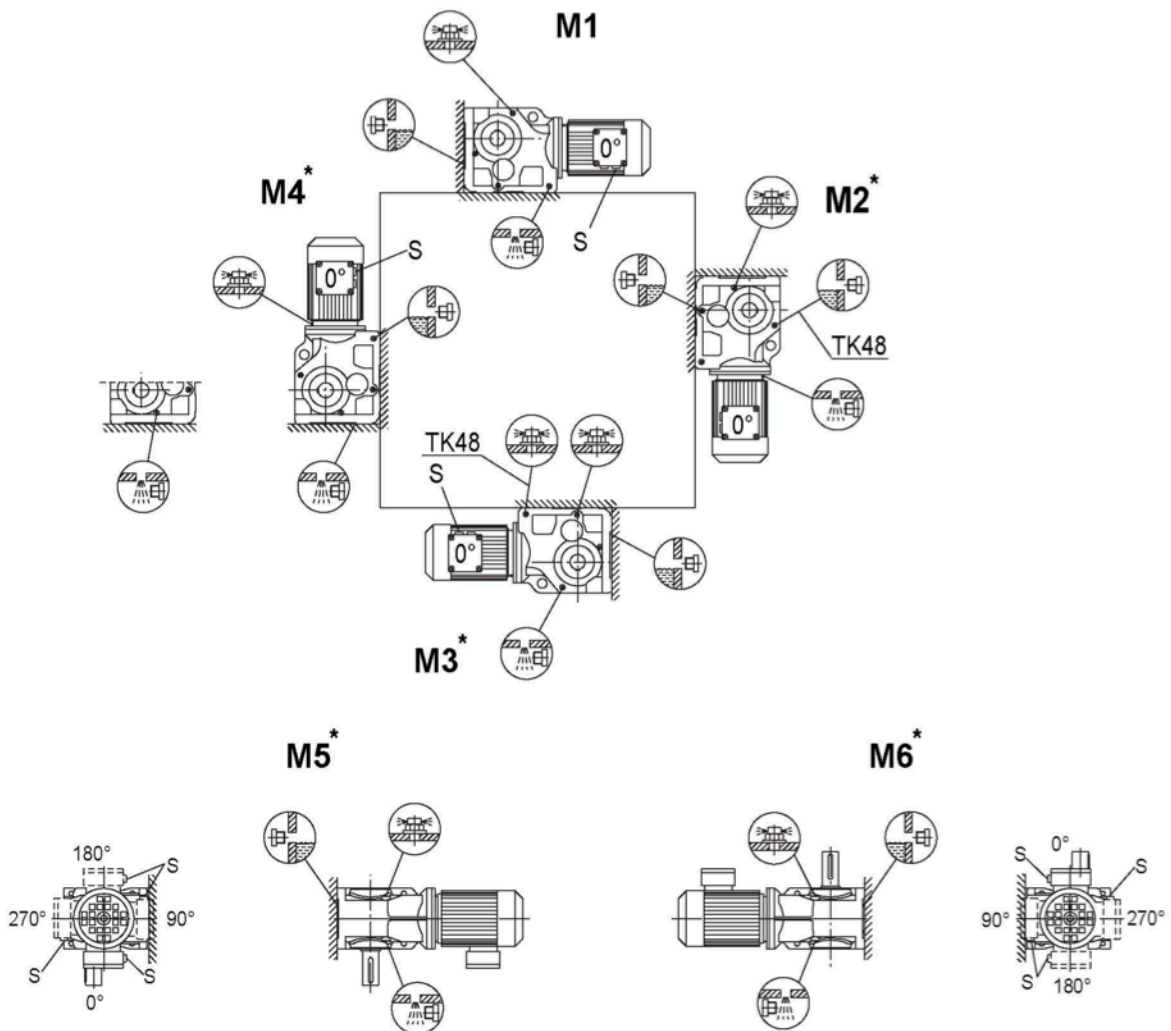
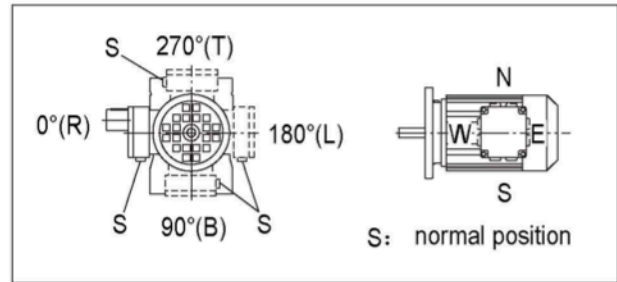

Mounting position	Gear unit size	Input speed [r/min]
M2*,M3*,M4*,M5*,M6*	78...108	>2500
	>108	>1500

Important: Please refer to the information in the 'Geared Motors' catalog, Sec. (page 47).

Mounting Positions

Mounting positions for helical-bevel gearmotors

TK168-188, TKH168B-188B

Symbol	Meaning
	Breather valve
	Oil level plug
	Oil drain plug

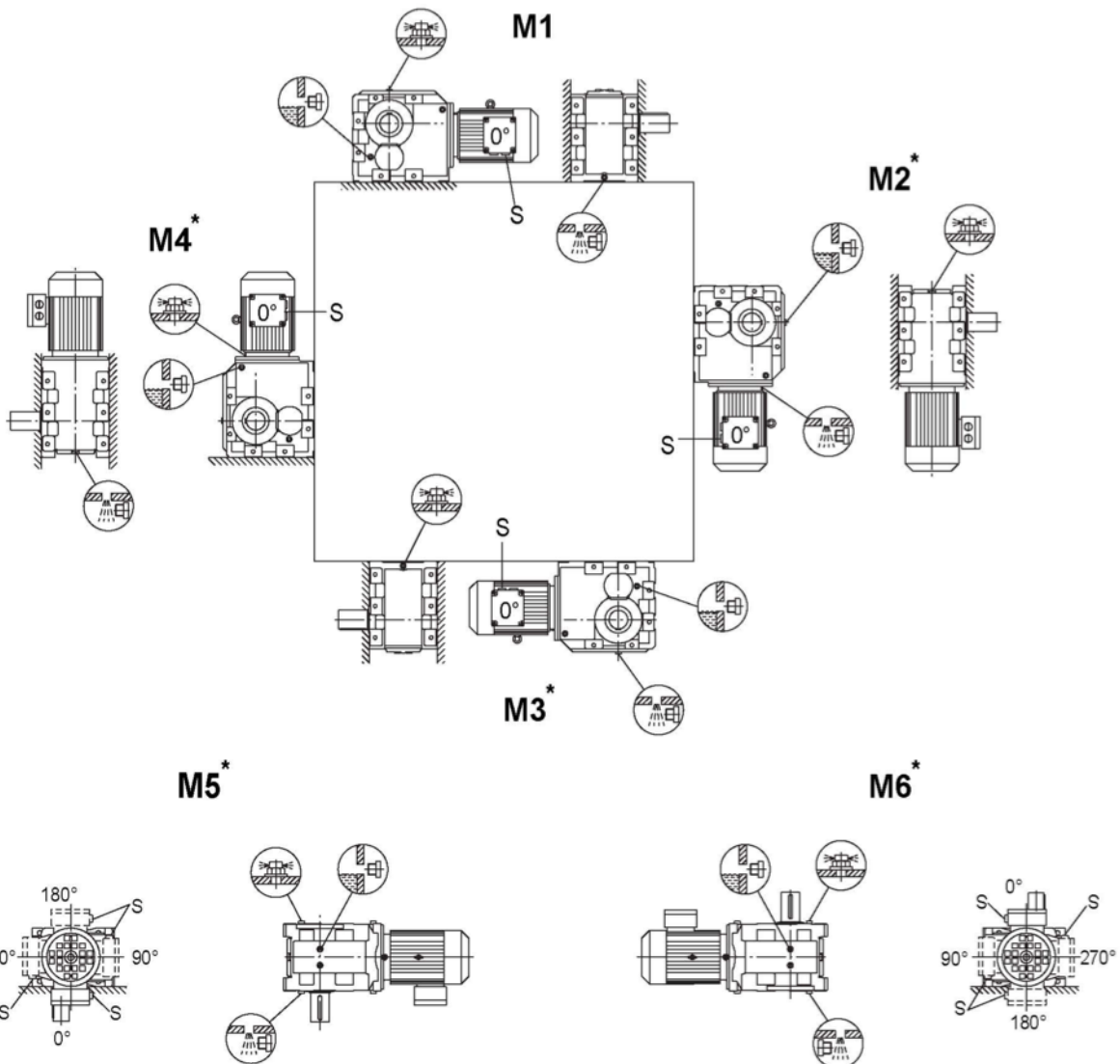
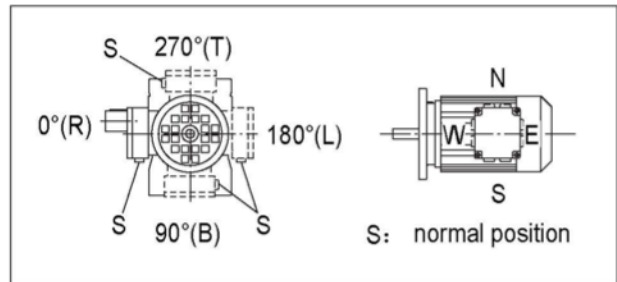

Mounting position	Gear unit size	Input speed [r/min]
M2*, M3*, M4*, M5*, M6*	78...108	>2500
	>108	>1500

Important: Please refer to the information in the 'Geared Motors' catalog, Sec. (page 47).

TKFITKAFITKHFITKAZITKHZ38-158,TKVF/TKVZ38-108

Symbol	Meaning
	Breather valve
	Oil level plug
	Oil drain plug

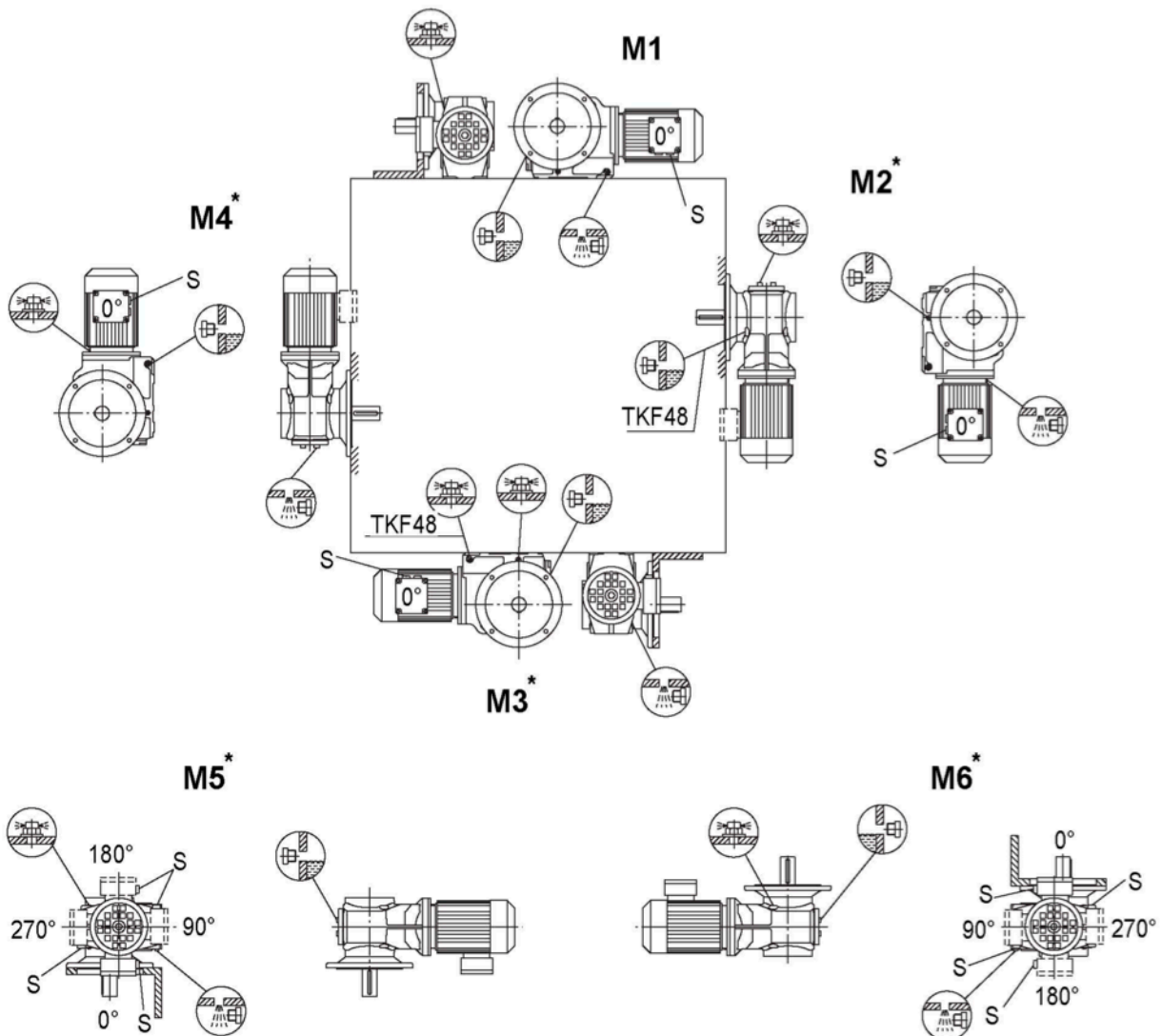
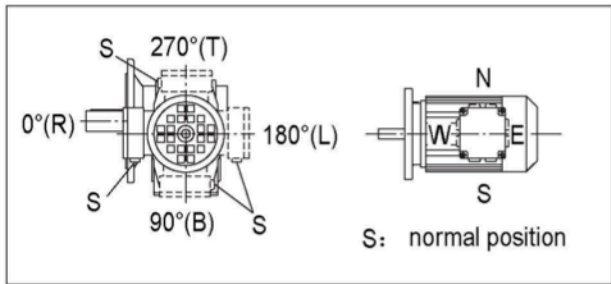

Mounting position	Gear unit size	Input speed [r/min]
M2*,M3*,M4*,M5*,M6*	78...108	>2500
	>108	>1500

Mounting Positions
Mounting positions for helical-bevel gearmotors

TKA/TKH38-158,TKV38-108

Symbol	Meaning
	Breather valve
	Oil level plug
	Oil drain plug

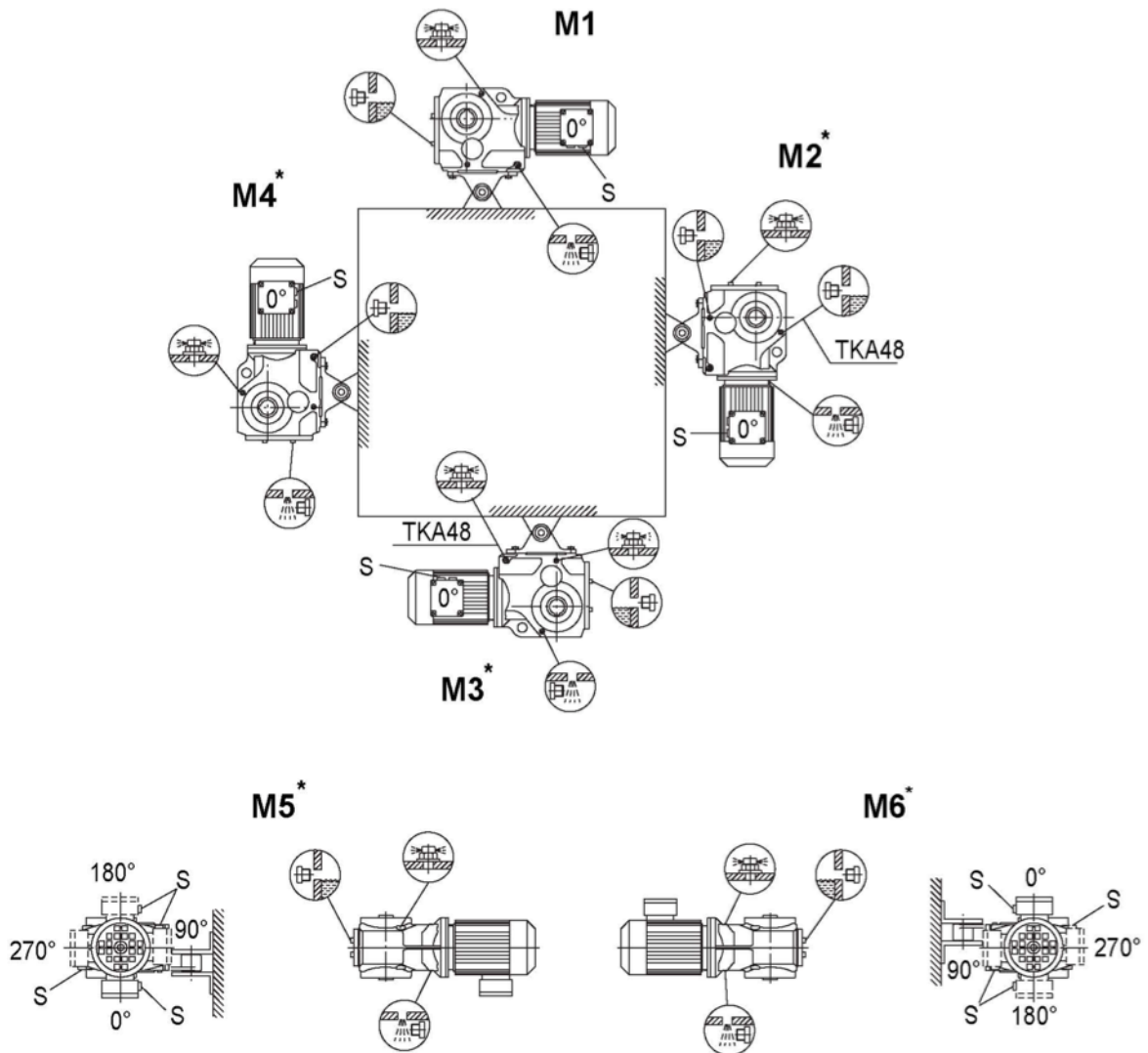
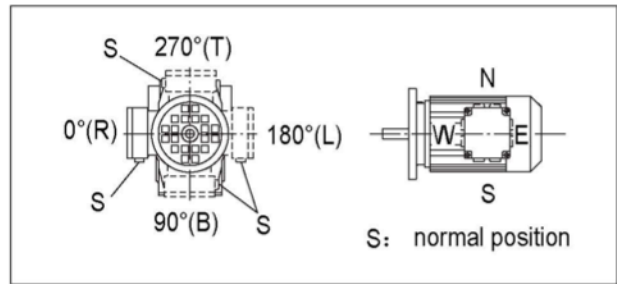

Mounting position	Gear unit size	Input speed [r/min]
M2*,M3*,M4*,M5*,M6*	78...108	>2500
	>108	>1500

TKFITKAFITKHFITKAZITKHZ38-158,TKVF/TKVZ38-108

Symbol	Meaning
	Breather valve
	Oil level plug
	Oil drain plug

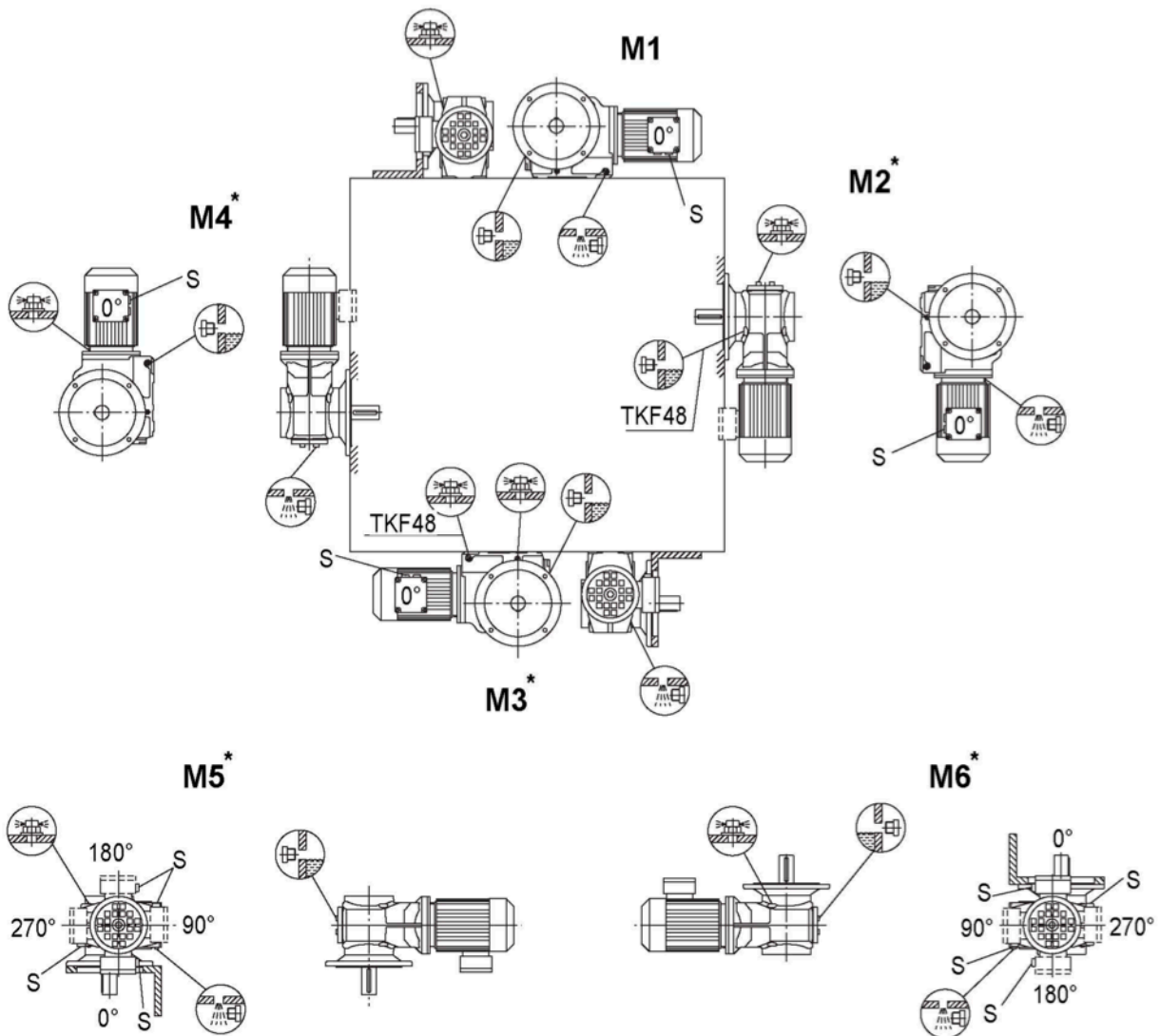
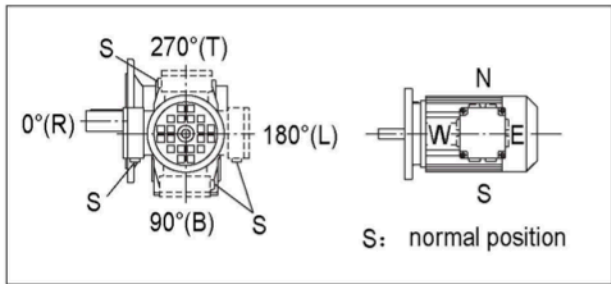

Mounting position	Gear unit size	Input speed [r/min]
M2*,M3*,M4*,M5*,M6*	78...108	>2500
	>108	>1500

8.6. Mounting positions for helical-worm gearmotors

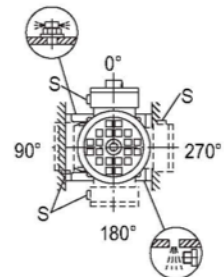
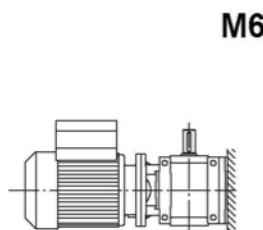
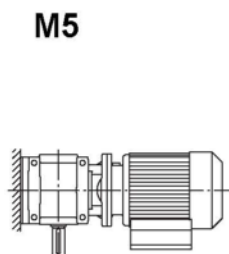
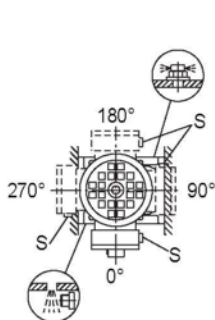
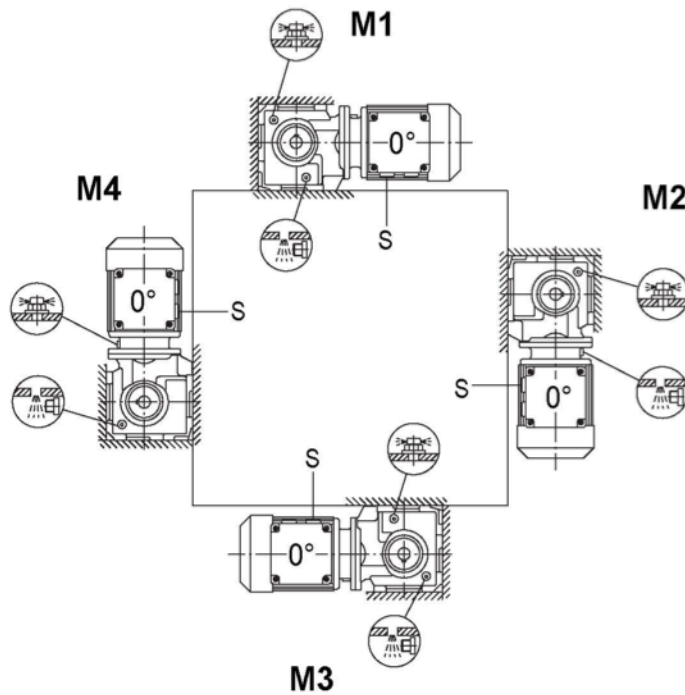
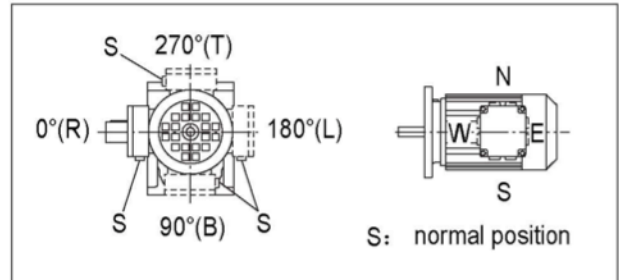

TS38

Symbol	Meaning
	Breather valve
	Oil level plug
	Oil drain plug



Important: Please refer to the **i** information in the 'Geared Motors' catalog, Sec. (page 47).

TS48-TS98

Symbol	Meaning
	Breather valve
	Oil level plug
	Oil drain plug

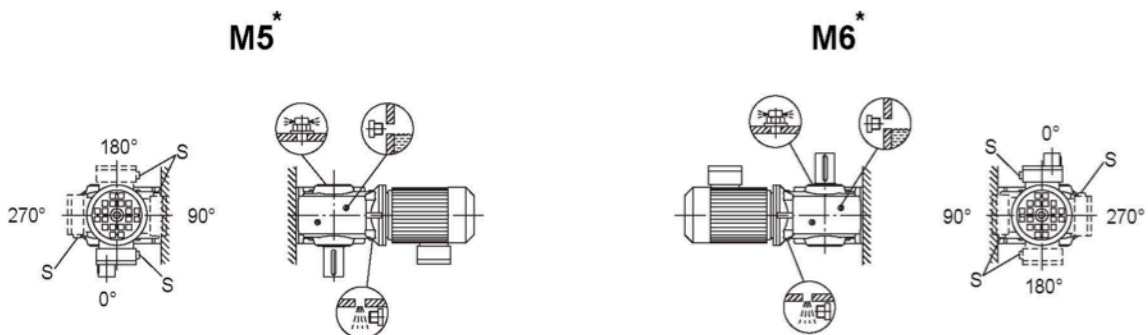
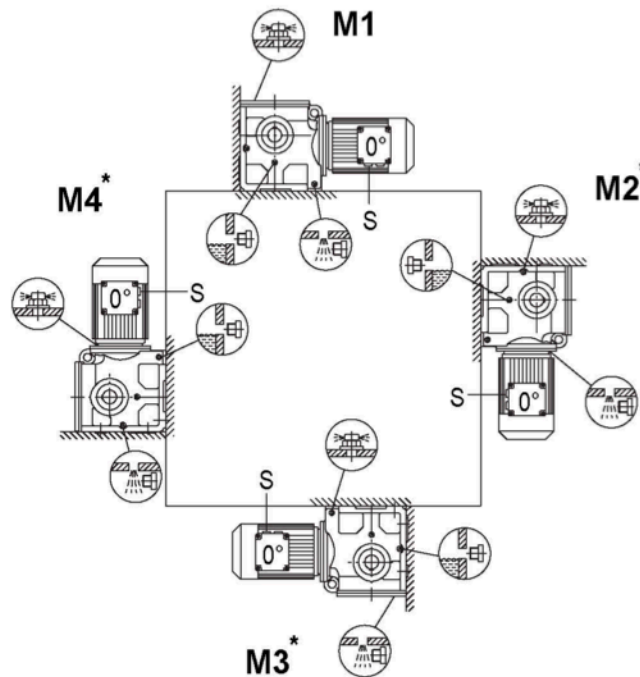
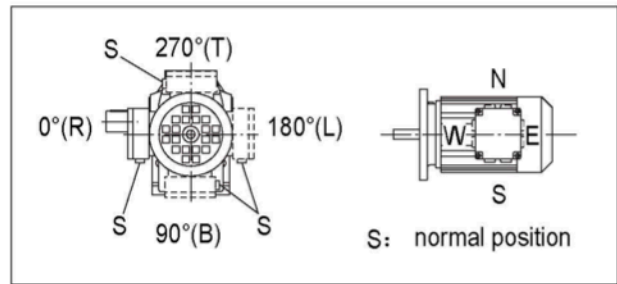



Mounting position	Gear unit size	Input speed [r/min]
M2*, M3*, M4*, M5*, M6*	78...98	>2500

Important: Please refer to the  information in the 'Geared Motors' catalog, Sec. (page 47).

Mounting Positions

Mounting positions for helical-worm gearmotors

TSF/ITSAF/ITSHF38

Symbol	Meaning
	Breather valve
	Oil level plug
	Oil drain plug

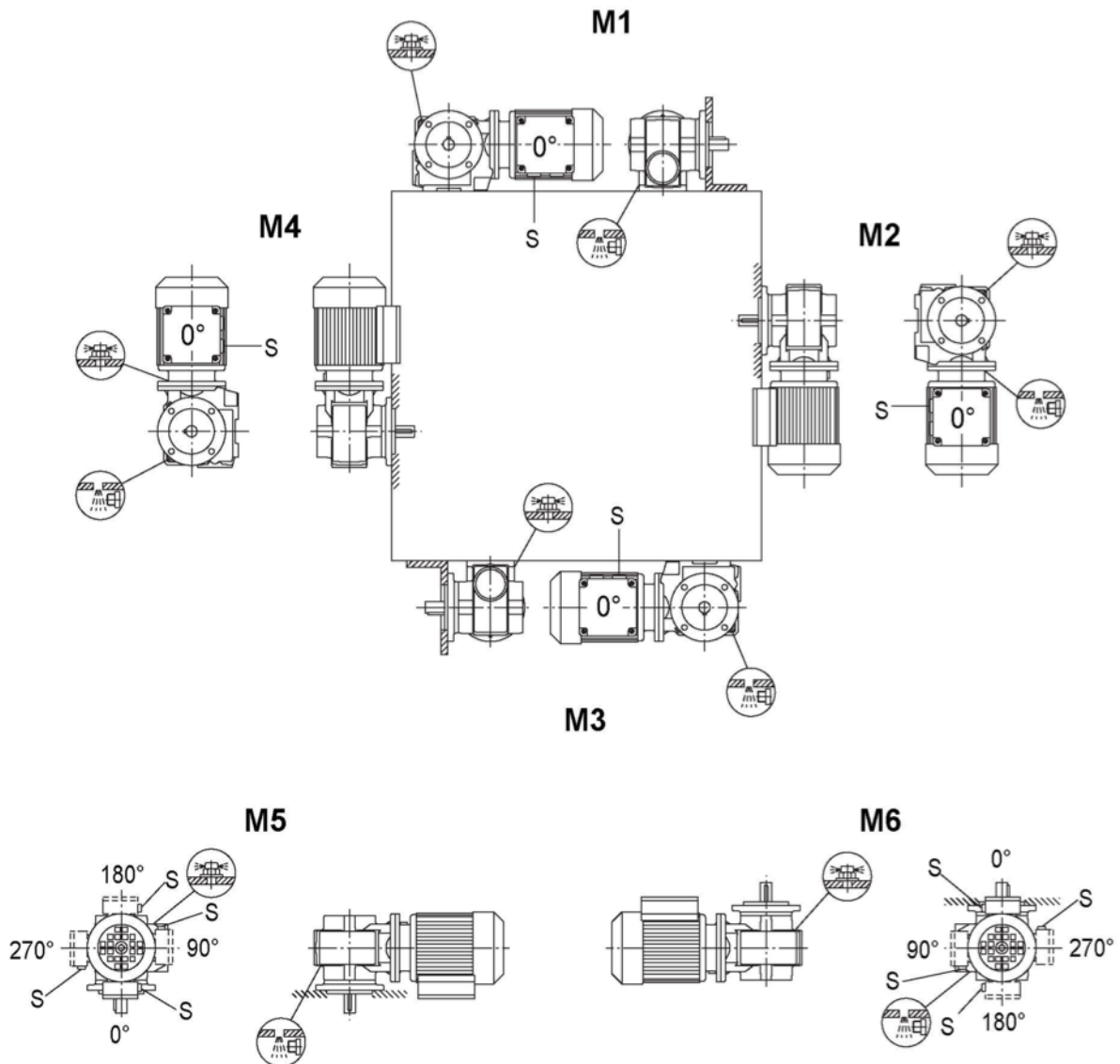
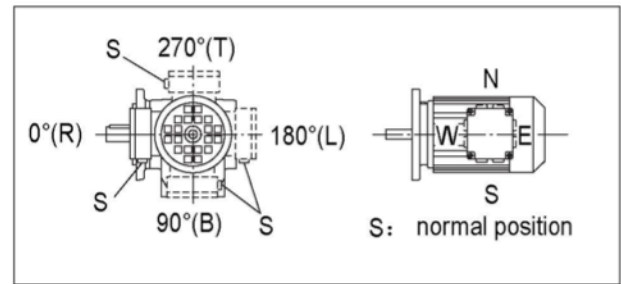

TSF/ITSAF/ITSHF/ITSAZ/ITSHZ48-98

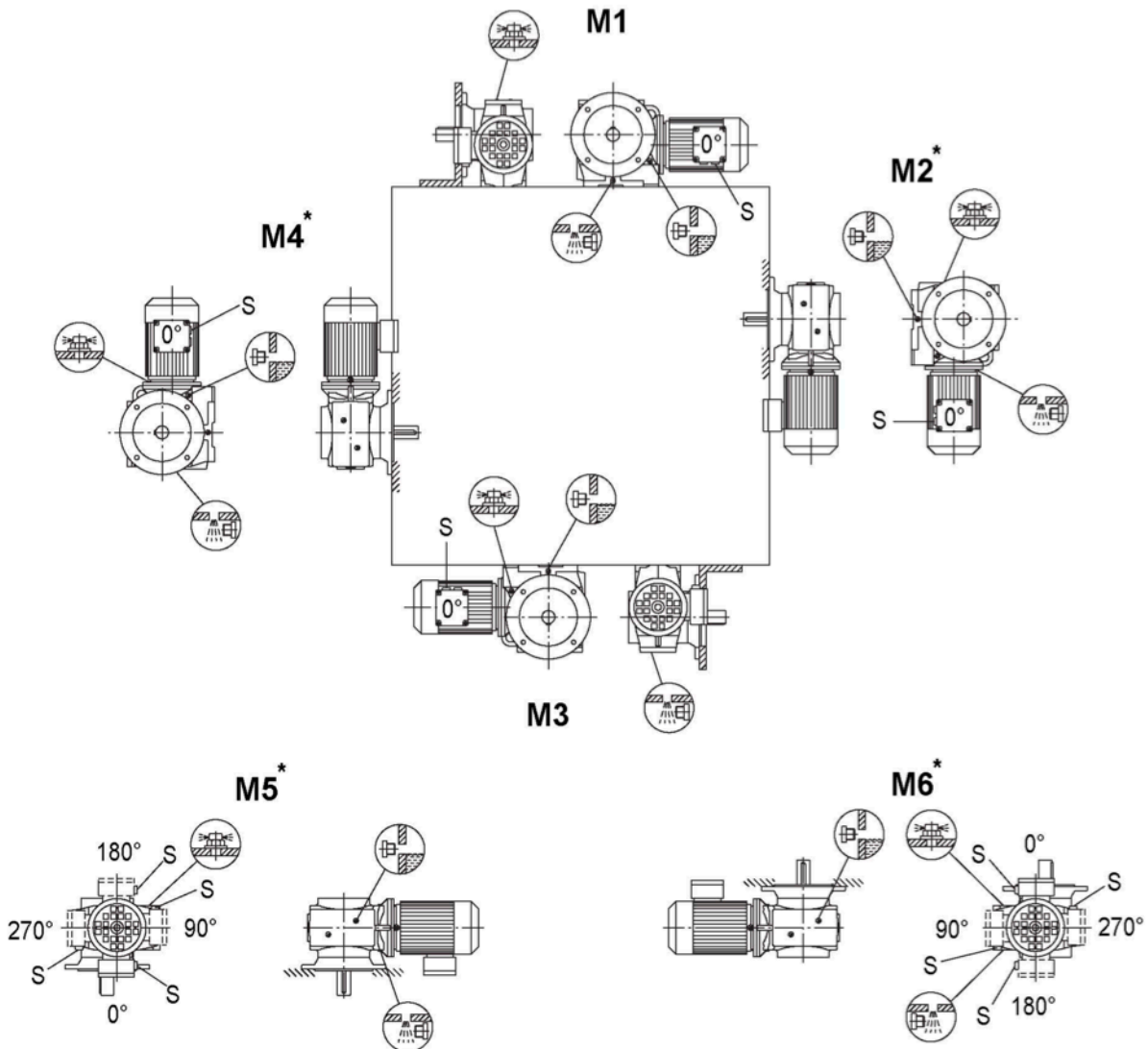
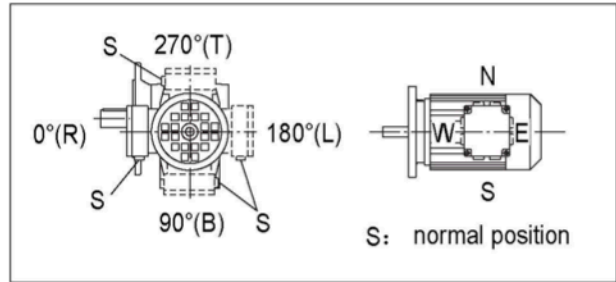

Symbol	Meaning
	Breather valve
	Oil level plug
	Oil drain plug



Mounting position	Gear unit size	Input speed [r/min]
M2*, M4*, M5*, M6*	78...98	>2500

Mounting Positions
Mounting positions for helical-worm gearmotors

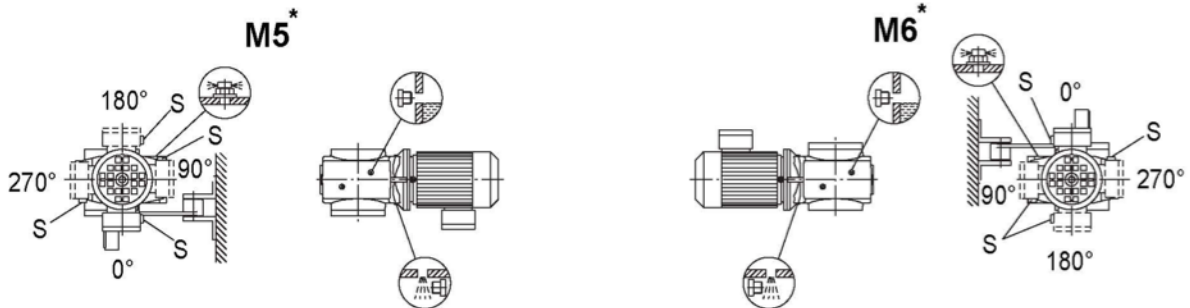
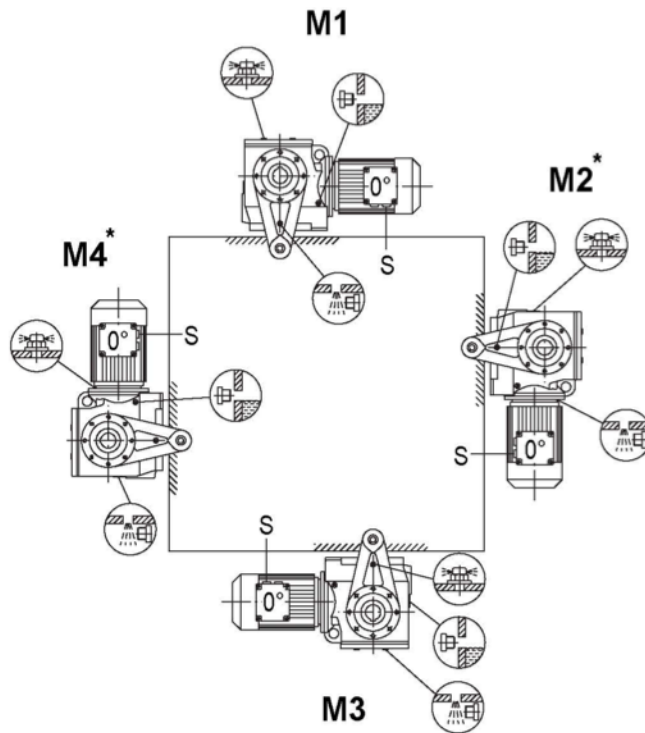
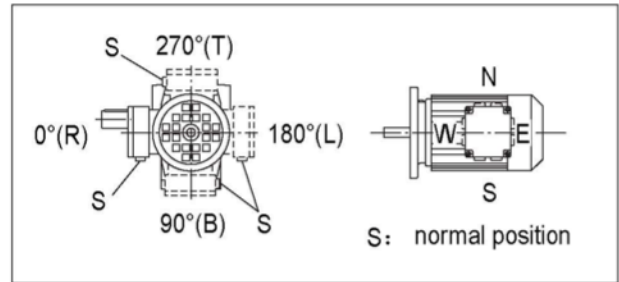

TSA/TSH48-98

Symbol	Meaning
	Breather valve
	Oil level plug
	Oil drain plug



Mounting position	Gear unit size	Input speed [r/min]
M2*, M4*, M5*, M6*	78...98	>2500

TSA/TSH38

Symbol	Meaning
	Breather valve
	Oil level plug
	Oil drain plug

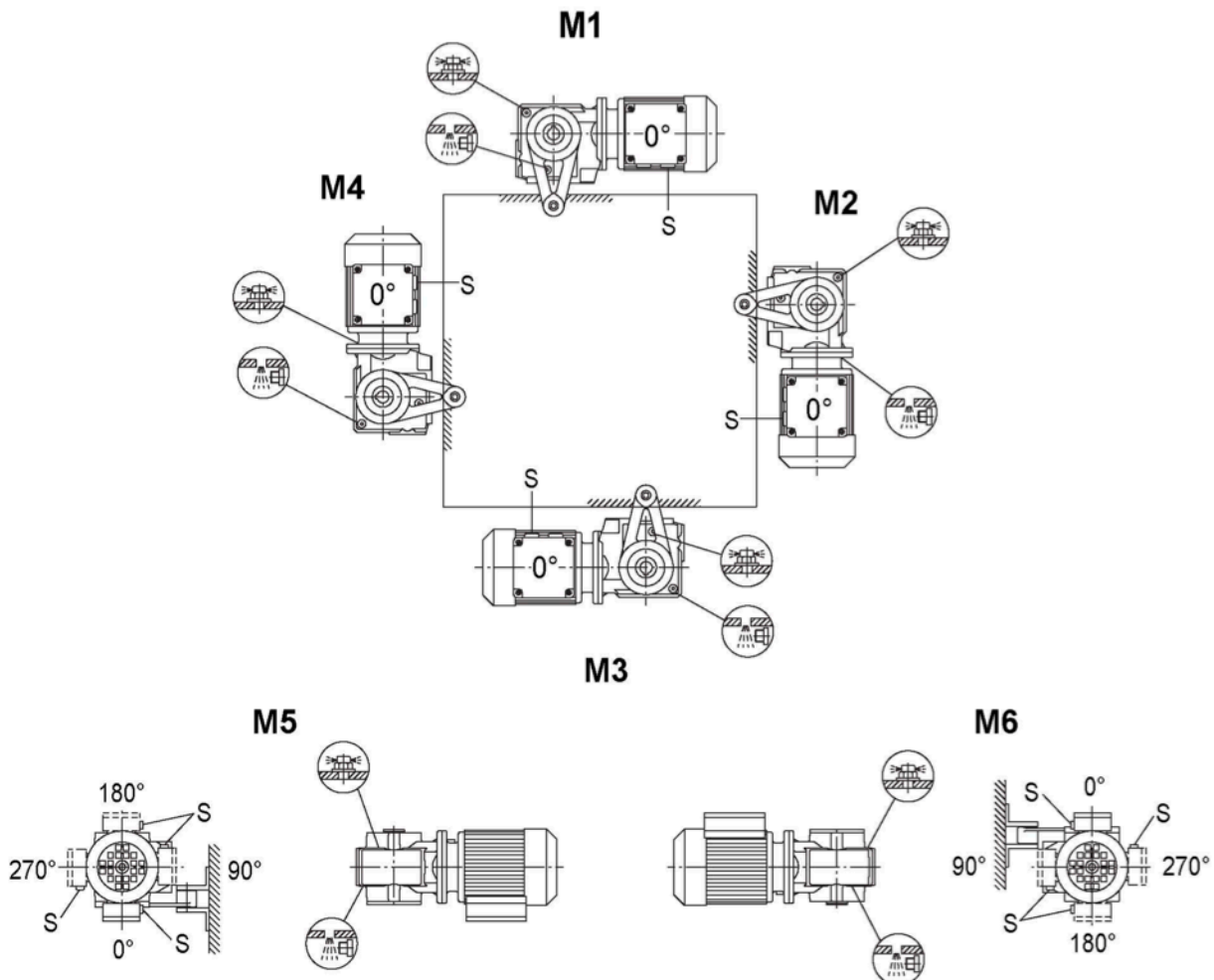
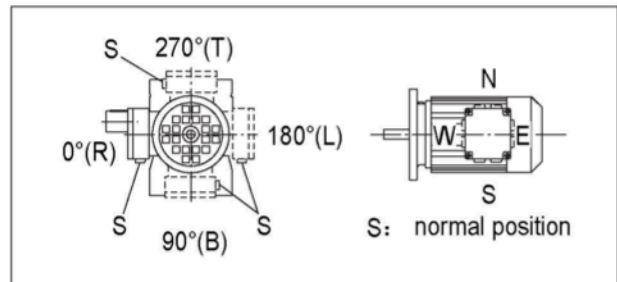

The data refer to the radial force acting midway on the shaft end (with right-angle gear units on the A-side output). Worst case conditions have been assumed for the force application angle α and the direction of rotation.

1. Only 50% of the F_{r2} value specified in the selection tables is permitted in mounting position M1 with wall attachment on the front face for TK and TS gear units.
2. Helical-bevel geared motors TK168 and TK188 in mounting positions M1 to M4: A maximum of 50% of the overhung load F_{r2} specified in the selection tables in the case of gear unit mounting other than as shown in the mounting position sheets.
3. Foot and flange-mounted helical gear units (TR..F): A maximum of 50% of the overhung load F_{r2} specified in the selection tables for torque transmission via flange..F mounting are permitted.

9 Lubricants

General information

Unless a special arrangement is made, we supplies the drives with a lubricant fill adapted for the specific gear unit and mounting position. The decisive factor is the mounting position (M1 ... M6, → Sec. "Mounting Positions and Important Order Information") specified when ordering the drive. You must adapt the lubricant fill in case of any subsequent changes made to the mounting position (→ Lubricant fill quantities).

Anti-friction bearing greases





The lubricant table on the following page shows the permitted lubricants for Transcyko units. Please note the following key to the lubricant table:

	Ambient temperature	Manufacturer	Type	Lubrication type
Anti-friction bearing in gear unit	-20°C ~ +60°C	Mobil	Mobilux EP 2	Mineral lubricant
	-40°C ~ +80°C	Mobil	Mobiltemp SHC 100	Synthetic lubricant
Anti-friction bearing in motor	-20°C ~ +80°C	Esso	Unirex EQ3	Mineral lubricant
	-20°C ~ +60°C	Shell	Alvania RL3	Mineral lubricant
	+80°C ~ +100°C	Klüber	Barrierta L55/2	Synthetic lubricant
	-45°C ~ .25°C	Shell	Aero Shell Grease 16	Synthetic lubricant

The following grease quantities are required:

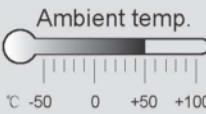
- For fast-running bearings (motor and gear unit input end): Fill the cavities between the rolling elements one third full with grease.
- For slow-running bearings (in gear units and at gear unit output end): Fill the cavities between the rolling elements two thirds full with grease.

9.1 Lubricant table

	Ambient temp. 					Lubrication type
	°C -50 0 +50 +100	ISO	SHELL	MOBIL	BP	
TR.. TF.. TK..	标准 Standard -10 +40	VG 220	Shell Omala 220	Mobilgear 630	BP Energol GR-XP 220	Mineral lubricant
	-20 +25	VG 150 VG 100	Shell Omala 100	Mobilgear 627	BP Energol GR-XP 100	
	-30 +10	VG 68-46 VG 32	Shell Tellus T 32	Mobil D.T.E. 13M		
	-40 -20	VG 22 VG 15	Shell Tellus T 15	Mobil D.T.E. 11M	BP Energol HLP-HM 15	Synthetic lubricant
	-40 +80	VG 220	Shell Omala HD 220	Mobil SHC 630		
	-40 +40	VG 150		Mobil SHC 629		
	-40 +10	VG 32		Mobil SHC 624		
TS..	-0 +40	VG680	Shell Omala 680	Mobilgear 636	BP Energol GR-XP 680	Mineral lubricant
	-20 +10	VG 150 VG 100	Shell Omala 100	Mobilgear 627	BP Energol GR-XP 100	
	-20 +60	VG 680 ¹⁾	Shell Tivela S 680		BP Energol GR-XP 680	Synthetic lubricant
	-30 +80	VG 460	Shell Omala HD 460	Mobil SHC 634		
	-40 +10	VG 150	Shell Omala HD 150	Mobil SHC 629		
	-25 +40	VG 220 ¹⁾	Shell Tivela S 220	Mobil Glygoyle 30		
	-40 0	VG 32		Mobil SHC 624		

9.1 Lubricant fill quantity

The specified fill quantities are recommended values. The precise values vary depending on the number of stages and gear ratio. When filling, it is essential to check the oil level plug since it indicates the precise oil capacity. The following tables show guide values for lubricant fill quantities in relation to the mounting position M1 ~ M6.

Helical (TR) gear units

TR../TR..F:

Gear units	Fill quantity in liters						unit : (L)
	M1**	M2**	M3	M4	M5	M6	
TR28/TR28F	0.25/0.40	0.70	0.50	0.70	0.50	0.50	
TR38/TR38F	0.30/0.95	0.85	0.95	1.05	0.75	0.95	
TR48/TR48F	0.70/1.50	1.60	1.50	1.65	1.50	1.50	
TR58/TR58F	0.80/1.70	1.90	1.70	2.10	1.70	1.70	
TR68/TR68F	1.10/2.30	2.60/3.50	2.80	3.20	1.80	2.00	
TR78/TR78F	1.20/3.00	3.80/4.10	3.60	4.10	2.50	3.40	
TR88/TR88F	2.30/6.0	6.7/8.2	7.20	7.70	6.30	6.50	
TR98	4.60/9.8	11.7/14.0	11.70	13.40	11.30	11.70	
TR108	6.0/13.7	16.30	16.90	19.20	13.20	15.90	
TR138	10.0/25.0	28.00	29.50	31.50	25.00	25.00	
TR148	15.4/40.0	46.50	48.00	52.00	39.50	41.00	
TR168	27.0/70.0	82.00	78.00	88.00	66.00	69.00	

TRF../TRZ..:

Gear units	Fill quantity in liters						unit : (L)
	M1**	M2**	M3	M4	M5	M6	
TRF/TRZ28	0.25/0.40	0.70	0.50	0.70	0.50	0.50	
TRF/TRZ38	0.35/0.95	0.90	0.95	1.05	0.75	0.95	
TRF/TRZ48	0.65/1.50	1.60	1.50	1.65	1.50	1.50	
TRF/TRZ58	0.80/1.70	1.80	1.70	2.00	1.70	1.70	
TRF/TRZ68	1.20/2.50	2.70/3.60	2.70	2.60	1.90	2.10	
TRF/TRZ78	1.20/2.60	3.80/4.10	3.30	4.10	2.40	3.00	
TRF/TRZ88	2.40/6.0	6.8/7.9	7.10	7.70	6.30	6.40	
TRF98	5.1/10.2	11.9/14.0	11.20	14.00	11.20	11.80	
TRF108	6.3/14.9	15.90	17.00	19.20	13.10	15.90	
TRF138	9.5/25.0	27.00	29.00	32.50	25.00	25.00	
TRF148	16.4/42.0	47.00	48.00	52.00	42.00	42.00	
TRF168	26.0/70.0	82.00	78.00	88.00	65.00	71.00	

Helical (TRX) gear units

TRX..:

Gear units	Fill quantity in liters						unit : (L)
	M1**	M2**	M3	M4	M5	M6	
TRX58	0.60	0.80	1.30	1.30	0.90	0.90	
TRX68	0.80	0.80	1.70	1.90	1.10	1.10	
TRX78	1.10	1.50	2.60	2.70	1.60	1.60	
TRX88	1.70	2.50	4.80	4.80	2.90	2.90	
TRX98	2.10	3.40	7.40	7.00	4.80	4.80	
TRX108	3.90	5.60	11.60	11.90	7.70	7.70	

** The large gear unit of multi-stage gear units must be filled with the larger oil volume.

Helical (TRX) gear units

TRXF...:

Gear units	Fill quantity in liters						unit : (L)
	M1**	M2**	M3	M4	M5	M6	
TRXF58	0.50	0.80	1.10	1.10	0.70	0.70	
TRXF68	0.70	0.80	1.50	1.40	1.00	1.00	
TRXF78	0.90	1.30	2.40	2.00	1.60	1.60	
TRXF88	1.60	1.95	4.90	3.95	2.90	2.90	
TRXF98	2.10	3.70	7.10	6.30	4.80	4.80	
TRXF108	3.10	5.70	11.20	9.30	7.20	7.20	

** The large gear unit of multi-stage gear units must be filled with the larger oil volume.

Parallel shaft helical (TF) gear units

TF...,TFA..B,TFH..B,TFV..B:

Gear units	Fill quantity in liters						unit : (L)
	M1	M2	M3	M4	M5	M6	
TF..28	0.60	0.80	0.70	0.70	0.60	0.60	
TF..38	0.95	1.25	0.70	1.25	1.00	1.10	
TF..48	1.50	1.80	1.10	1.90	1.50	1.70	
TF..58	2.6	3.5	2.1	3.5	2.8	2.9	
TF..68	2.7	3.8	1.90	3.8	2.9	3.2	
TF..78	5.9	7.3	4.3	8.0	6.0	6.3	
TF..88	10.8	13.0	7.7	13.8	10.8	11.0	
TF..98	18.5	22.5	12.6	25.2	18.5	20.0	
TF..108	24.5	32.0	19.5	37.5	27.0	27.0	
TF..128	40.5	55	34.0	61	46.5	47.0	
TF..158	69	104	63	105	86	78	

TFF...:

Gear units	Fill quantity in liters						unit : (L)
	M1	M2	M3	M4	M5	M6	
TFF28	0.60	0.80	0.70	0.70	0.60	0.60	
TFF38	1.00	1.25	0.70	1.30	1.00	1.10	
TFF48	1.60	1.85	1.10	1.90	1.50	1.70	
TFF58	2.8	3.5	2.1	3.7	2.9	3.0	
TFF68	2.7	3.8	1.90	3.8	2.9	3.2	
TFF78	5.9	7.3	4.3	8.1	6.0	6.3	
TFF88	10.8	13.2	7.8	14.1	11.0	11.2	
TFF98	19.0	22.5	12.6	25.5	18.9	20.5	
TFF108	25.5	32.0	19.5	38.5	27.5	28.0	
TFF128	41.5	56	34.0	63	46.5	49.0	
TFF158	72	105	64	106	87	79	

Parallel shaft helical (TF) gear units

TFA...,TFH...,TFV...,TFAF...,TFHF...,TFVF...,TFAZ...,TFHZ...,TFVZ...:

Gear units	Fill quantity in liters						unit : (L)
	M1	M2	M3	M4	M5	M6	
TF..28	0.60	0.80	0.70	0.70	0.60	0.60	
TF..38	0.95	1.25	0.70	1.25	1.00	1.10	
TF..48	1.50	1.80	1.10	1.90	1.50	1.70	
TF..58	2.7	3.5	2.1	3.4	2.9	3.0	
TF..68	2.7	3.8	1.90	3.8	2.9	3.2	
TF..78	5.9	7.3	4.3	8.0	6.0	6.3	
TF..88	10.8	13.0	7.7	13.8	10.8	11.0	
TF..98	18.5	22.5	12.6	25.0	18.5	20.0	
TF..108	24.5	32.0	19.5	37.5	27.0	27.0	
TF..128	39.0	55	34.0	61	45.0	46.5	
TF..158	68	103	62	104	85	77	

Helical-bevel (TK) gear units

TK...,TKA..B,TKH..B,TKV..B:

Gear units	Fill quantity in liters						unit : (L)
	M1	M2	M3	M4	M5	M6	
TK..38	0.50	1.00	1.00	1.30	0.95	0.95	
TK..48	0.80	1.30	1.50	2.0	1.60	1.60	
TK..58	1.20	2.3	2.5	3.0	2.6	2.4	
TK..68	1.10	2.4	2.6	3.4	2.6	2.6	
TK..78	2.2	4.1	4.4	5.9	4.2	4.4	
TK..88	3.7	8.0	8.7	10.9	8.0	8.0	
TK..98	7.0	14.0	15.7	20.0	15.7	15.5	
TK..108	10.0	21.0	25.5	33.5	24.0	24.0	
TK..128	21.0	41.5	44.0	54	40.0	41.0	
TK..158	31.0	62	62	90	58	62	
TK..168	33.0	95	105	123	85	84	
TK..188	53	152	167	200	143	143	

TKF...:

Gear units	Fill quantity in liters						unit : (L)
	M1	M2	M3	M4	M5	M6	
TKF38	0.50	1.00	1.00	1.50	1.00	1.00	
TKF48	0.80	1.30	1.70	2.2	1.60	1.60	
TKF58	1.30	2.3	2.7	3.2	2.9	2.7	
TKF68	1.10	2.4	2.8	3.6	2.7	2.7	
TKF78	2.1	4.1	4.4	6.0	4.5	4.5	
TKF88	3.7	8.2	9.0	11.9	8.4	8.4	
TKF98	7.0	14.7	17.3	21.5	15.7	16.5	
TKF108	10.0	22.0	26.0	35.0	25.0	25.0	
TKF128	21.0	41.5	46.0	55	41.0	41.0	
TKF158	31.0	66	69	92	62	62	

Helical-bevel (TK) gear units

TKA..., TKH..., TKV..., TKAF..., TKHF..., TKVF..., TKAZ..., TKHZ..., TKVZ...:

Gear units	Fill quantity in liters						unit : (L)
	M1	M2	M3	M4	M5	M6	
TK..38	0.50	1.00	1.00	1.40	1.00	1.00	
TK..48	0.80	1.30	1.60	2.1	1.60	1.60	
TK..58	1.30	2.3	2.7	3.2	2.9	2.7	
TK.68	1.10	2.4	2.7	3.6	2.6	2.6	
TK..78	2.1	4.1	4.6	6.0	4.4	4.4	
TK..88	3.7	8.2	8.8	11.1	8.0	8.0	
TK..98	7.0	14.7	15.7	20.0	15.7	15.7	
TK..108	10.0	20.5	24.0	32.0	24.0	24.0	
TK..128	21.0	41.5	43.0	52	40.0	40.0	
TK..158	31.0	66	67	87	62	62	
TK..168	33.0	95	105	123	85	84	
TK..188	53	152	167	200	143	143	

Helical-worm (TS) gear units

TS.. :

Gear units	Fill quantity in liters						unit : (L)
	M1	M2	M3**	M4	M5	M6	
TS38	0.25	0.40	0.50	0.55	0.40	0.40	
TS48	0.35	0.80	0.70/0.90	1.00	0.80	0.80	
TS58	0.50	1.20	1.00/1.20	1.45	1.30	1.30	
TS68	1.00	2.0	2.2/3.1	3.1	2.6	2.6	
TS78	1.90	4.2	3.7/5.4	5.9	4.4	4.4	
TS88	3.3	8.1	6.9/10.4	12.0	8.4	8.4	
TS98	6.8	15.0	13.4/18.0	22.5	17.0	17.0	

TSF.. :

Gear units	Fill quantity in liters						unit : (L)
	M1	M2	M3**	M4	M5	M6	
TSF38	0.25	0.40	0.50	0.55	0.40	0.40	
TSF48	0.40	0.90	0.90/1.10	1.05	1.00	1.00	
TSF58	0.50	1.20	1.00/1.50	1.55	1.40	1.40	
TSF68	1.00	2.2	2.2/3.0	3.2	2.7	2.7	
TSF78	1.90	4.1	3.9/5.8	6.5	4.9	4.9	
TSF88	3.8	8.0	7.1/10.1	12.0	9.1	9.1	
TSF98	7.4	15.0	13.8/18.8	23.6	18.0	18.0	

** The large gear unit of multi-stage gear units must be filled with the larger oil volume.

Helical-worm (TS) gear units

TSA..,TSH..,TSAF..,TSHF..,TSAZ..,TSHZ.. :

Gear units	Fill quantity in liters						unit : (L)
	M1	M2	M3**	M4	M5	M6	
TS..38	0.25	0.40	0.50	0.50	0.40	0.40	
TS..48	0.40	0.80	0.70/0.90	1.00	0.80	0.80	
TS..58	0.50	1.10	1.00/1.50	1.50	1.20	1.20	
TS..68	1.00	2.0	1.80/2.6	2.9	2.5	2.5	
TS..78	1.80	3.9	3.6/5.0	5.8	4.5	4.5	
TS..88	3.8	7.4	6.0/8.7	11.2	8.0	8.0	
TS..98	7.0	14.0	11.4/16.0	21.0	15.7	15.7	

** The large gear unit of multi-stage gear units must be filled with the larger oil volume.